

INDUSTRIAL CHEMISTRY

BEING A SERIES OF VOLUMES GIVING  
A COMPREHENSIVE SURVEY OF

THE CHEMICAL INDUSTRIES

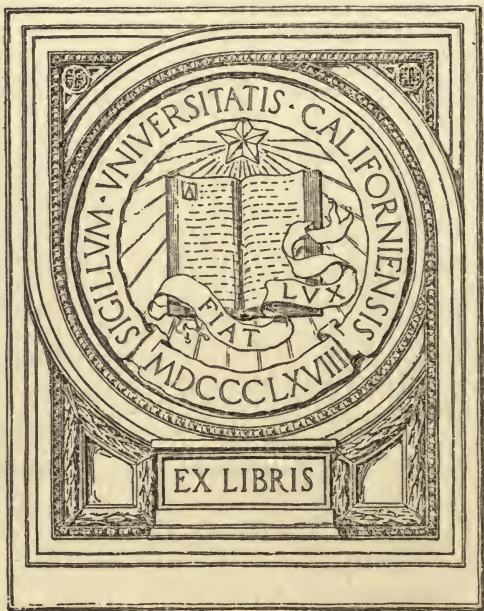

EX LIBRIS

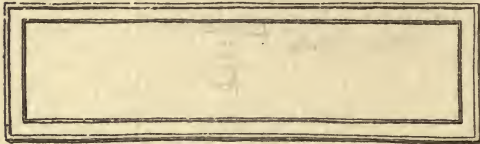









# INDUSTRIAL CHEMISTRY

BEING A SERIES OF VOLUMES GIVING A  
COMPREHENSIVE SURVEY OF

## THE CHEMICAL INDUSTRIES

EDITED BY SAMUEL RIDEAL, D.Sc. LOND., F.I.C.

FELLOW OF UNIVERSITY COLLEGE, LONDON

ASSISTED BY

JAMES A. AUDLEY, B.Sc., F.I.C.	R. S. MORRELL, M.A., Ph.D.
W. BACON, B.Sc., F.I.C., F.C.S.	J. R. PARTINGTON, M.A., Ph.D.
E. DE BARRY BARNETT, B.Sc., A.I.C.	ARTHUR E. PRATT, B.Sc., Assoc. R.S.M.
M. BARROWCLIFF, F.I.C.	ERIC K. RIDEAL, M.A., Ph.D., F.I.C.
H. GARNER BENNETT, M.Sc.	W. H. SIMMONS, B.Sc., F.I.C.
F. H. CARR, F.I.C.	R. W. SINDALL, F.C.S.
S. HOARE COLLINS, M.Sc., F.I.C.	HUGH S. TAYLOR, D.Sc.
H. C. GREENWOOD, O.B.E., D.Sc., F.I.C.	ARMAND DE WAELE, B.Sc.
	C. M. WHITTAKER, B.Sc.

&c., &c.





# INDUSTRIAL GASES

BY

HAROLD CECIL GREENWOOD

O.B.E., D.Sc. (MANCHESTER), F.I.C.

SCIENTIFIC ADVISER, MUNITIONS INVENTIONS DEPARTMENT  
FORMERLY BEYER FELLOW AND 1851 EXHIBITION SCHOLAR OF  
THE UNIVERSITY OF MANCHESTER



NEW YORK  
D. VAN NOSTRAND COMPANY\*

25 PARK PLACE

1919

TP242  
G8

WBAI - JAMES EARL RAY

WBAI - JAMES EARL RAY

WBAI - JAMES EARL RAY

PRINTED IN GREAT BRITAIN

## GENERAL PREFACE

THE rapid development of Applied Chemistry in recent years has brought about a revolution in all branches of technology. This growth has been accelerated during the war, and the British Empire has now an opportunity of increasing its industrial output by the application of this knowledge to the raw materials available in the different parts of the world. The subject in this series of handbooks will be treated from the chemical rather than the engineering standpoint. The industrial aspect will also be more prominent than that of the laboratory. Each volume will be complete in itself, and will give a general survey of the industry, showing how chemical principles have been applied and have affected manufacture. The influence of new inventions on the development of the industry will be shown, as also the effect of industrial requirements in stimulating invention. Historical notes will be a feature in dealing with the different branches of the subject, but they will be kept within moderate limits. Present tendencies and possible future developments will have attention, and some space will be devoted to a comparison of industrial methods and progress in the chief producing countries. There will be a general bibliography, and also a select bibliography to follow each section. Statistical information will only be introduced in so far as it serves to illustrate the line of argument.

Each book will be divided into sections instead of chapters, and the sections will deal with separate branches of the subject in the manner of a special article or monograph. An attempt will, in fact, be made to get away from

the orthodox textbook manner, not only to make the treatment original, but also to appeal to the very large class of readers already possessing good textbooks, of which there are quite sufficient. The books should also be found useful by men of affairs having no special technical knowledge, but who may require from time to time to refer to technical matters in a book of moderate compass, with references to the large standard works for fuller details on special points if required.

To the advanced student the books should be especially valuable. His mind is often crammed with the hard facts and details of his subject which crowd out the power of realizing the industry as a whole. These books are intended to remedy such a state of affairs. While recapitulating the essential basic facts, they will aim at presenting the reality of the living industry. It has long been a drawback of our technical education that the college graduate, on commencing his industrial career, is positively handicapped by his academic knowledge because of his lack of information on current industrial conditions. A book giving a comprehensive survey of the industry can be of very material assistance to the student as an adjunct to his ordinary textbooks, and this is one of the chief objects of the present series. Those actually engaged in the industry who have specialized in rather narrow limits will probably find these books more readable than the larger textbooks when they wish to refresh their memories in regard to branches of the subject with which they are not immediately concerned.

The volume will also serve as a guide to the standard literature of the subject, and prove of value to the consultant, so that, having obtained a comprehensive view of the whole industry, he can go at once to the proper authorities for more elaborate information on special points, and thus save a couple of days spent in hunting through the libraries of scientific societies.

As far as this country is concerned, it is believed that the general scheme of this series of handbooks is unique, and it is confidently hoped that it will supply mental

munitions for the coming industrial war. I have been fortunate in securing writers for the different volumes who are specially connected with the several departments of Industrial Chemistry, and trust that the whole series will contribute to the further development of applied chemistry throughout the Empire.

SAMUEL RIDEAL.



## FOREWORD

BY

DR. J. A. HARKER, F.R.S.

It is with the deepest regret that, on the eve of publication of this book, I have to record the untimely death of the author.

For the past three years Dr. Greenwood had been in charge of the division of the Research Laboratory of the Ministry of Munitions at University College, dealing with the synthesis of ammonia from its elements. As Director of the Laboratory, I have come into close contact with him for more than three years past, and have therefore had a unique opportunity of forming a judgment of the high value of the work he has accomplished. It is undoubtedly largely due to his untiring energy, research ability and wide knowledge, that a sure foundation has been laid for the future development of the synthetic ammonia industry in this country.

Although only thirty-two years of age, he had lived long enough to establish a scientific record of which a man of more advanced years might well be proud. Among the long list of his published researches may be cited those on the reduction of refractory oxides, the production of ferro alloys and the determination of the boiling-points of metals at high temperatures and under varying pressures. All these were carried out at Manchester University. As 1851 Exhibition Scholar Greenwood worked ten years ago under Professor Haber at Karlsruhe on the study of catalysts for ammonia synthesis.

## FOREWORD

He was awarded the degree of D.Sc. from Manchester University in 1912 at the early age of twenty-five, and the Fellowship of the Institute of Chemistry in 1918, and the O.B.E. in the present year.

The contents of this volume testify to the thoroughness of his knowledge in an important branch of modern chemistry, but only those who have had the privilege of working with him can fully realize the great loss which science has suffered by the sudden termination of so brilliant a career.

J. A. HARKER.

MINISTRY OF MUNITIONS,

24, OLD QUEEN STREET,  
LONDON, S.W. 1.

*November, 1919.*



## AUTHOR'S PREFACE

THE main aims of this book on Industrial Gases are to give a general account of the manufacture and technical manipulation of gases, to describe briefly the development and general principles of industrial gas technology and to present a collection of data likely to be useful in connection with such technology.

Many branches of gas manufacture are still in course of vigorous development, the war having been responsible for much progress, *e.g.* in the production of hydrogen, for aeronautical purposes and also for industrial processes such as the manufacture of synthetic ammonia. On this account it is difficult to give in all cases a final picture of the subject, an indication of the present trend being all that is practicable.

This and other considerations have caused me to concentrate more on the elucidation of general principles than on very detailed treatment of the various processes involved. Indeed, the latter alternative would have been impracticable in the present volume on account of the enormous field to be covered.

Special attention has been paid to the question of gaseous equilibria; the ever-growing importance of heterogeneous catalytic gas reactions is a feature of the present situation.

In the introductory chapter the more important general considerations relating to the manufacture and use of gases are briefly discussed, while tables of reference data in the form required for immediate use in technical practice are appended.

From this book have been excluded certain gases such as hydrogen chloride, chlorine, ammonia, etc., which are treated elsewhere in this series. In view of the dependence on fuel gases of most of the important industrial gases for their manufacture and on account of the intimate connection of the methods of production of fuel gases with the general

question of industrial gases, a concise survey of the manufacture and applications of gaseous fuels has been included. The subject is not treated exhaustively as it will be further elaborated in a later volume of this series.

Throughout the book considerable attention has been devoted to patents where such patents relate to differences in principle ; although much of the subject-matter of patent literature is superficial and crude, there is valuable historical and technical information to be obtained from the same.

A word may be said here with regard to units. While the metric system has many undoubted advantages in dealing with gases as in other connections, it is not in common usage in this country and consequently all gases have been considered on the basis of 1000 ft.<sup>3</sup> at 15° C. under a pressure of one atmosphere. As regards thermal quantities, since all modern chemical works now use the Centigrade thermometer, the usual B.T.U. has been replaced by the more convenient C.H.U. (Centigrade Heat Unit).

Free use has been made in some cases of many excellent existing textbooks, from which matter and references have been drawn.

Further, I desire to express my thanks for information received from various sources, especially to the following : Sir George Beilby, Messrs. A. Boake, Roberts & Co., Ltd., Mr. E. M. Boote, Messrs. The Carbonic Acid Gas Co., Messrs. R. & J. Dempster, Ltd., Dr. R. Lessing, and Dr. E. B. Maxted. Assistance was also given by the late Thos. Tyrer.

Finally, I must record my indebtedness to my wife, Mary G. Greenwood, B.Sc., for her constant help in the collection of information and the revision of the MS.

H. C. G.

LONDON,

*October, 1919.*

# CONTENTS

	PAGE
GENERAL PREFACE . . . . .	v
AUTHOR'S PREFACE . . . . .	ix
CONTENTS . . . . .	xi
INTRODUCTION . . . . .	I
Avogadro's Hypothesis. Laws of Gay Lussac and Dalton. Boyle's Law. Law of Charles and Gay Lussac. Absolute zero of temperature. Solution: Henry's Law; Dalton's Law. Sorption. Diffusion. Per- meability of materials. Critical temperature and pressure. Permanent gases and vapours. Joule-Thomson Effect. Specific heats of gases. Latent heats of vaporisation and fusion. Thermochemistry. Thermo- dynamical principles governing chemical equilibria in the gaseous state; the chemical constant. Velocity of reaction. Heterogeneous catalytic gas reactions: reaction velocity; output and completeness. Viscosity of gases: stream-line and turbulent motion. Resistance to flow of gases. Influence of difference in level. Physical methods of testing the purity of gases: gas interferometer; density; effusion; acoustical methods. Separation of gaseous mixtures. Separation of liquid or solid particles from gases. Methods of measuring volumes and rates of flow of gases. Automatic safety and purity tests. The compression of gases: work of compression; adiabatic compression; isothermal com- pression. Notes on compressed gases: safety precautions. Liquefied gases. Heat-interchange. Desiccation of gases. The storage of gas. Reference data. References . . . . .	I

---

## PART I.

### THE GASES OF THE ATMOSPHERE

#### SECTION I.—AIR.

Properties of air. Composition of the atmosphere . . . . .	58
The liquefaction of the permanent gases (air). Theory of cooling by the Joule-Thomson Effect: expansion at $-100^{\circ}\text{C}$ .; the case of hydrogen .	60
MANUFACTURE OF LIQUID AIR: Useful constants. Hampson system. Linde system: effect of pre-cooling. Claude system . . . . .	69
Properties of liquid air. Applications of liquid air. Separation of the con- stituents of liquid air: theoretical considerations . . . . .	77

	PAGE
MANUFACTURE OF OXYGEN AND NITROGEN. Linde system: Oxygen plants Nitrogen plants. New Linde system. Claude system. Pictet system . . . . .	81
Separation of the rare gases . . . . .	92
References . . . . .	92

---

## SECTION II.—OXYGEN.

Properties of oxygen . . . . .	93
MANUFACTURE :	
General . . . . .	94
By the fractionation of liquid air . . . . .	94
By electrolysis . . . . .	94
By alternate formation and decomposition of higher oxides, etc. . . . .	95
By auto-combustion methods . . . . .	98
By the action of water on peroxides and the like . . . . .	98
By physical methods (in the gaseous state) . . . . .	99
Compression of oxygen . . . . .	100
Comparison of costs of production and purity attainable by different processes	101
Applications of oxygen: scientific and laboratory uses; therapeutic uses; welding and cutting of metals; other applications . . . . .	102
Oxygen-enriched air: use in the blast furnace; use in the arc process for nitrogen fixation; use in the Häusser process; other applications . . . . .	106
Estimation and testing of oxygen . . . . .	108
References . . . . .	109

---

## SECTION III.—NITROGEN.

Properties of nitrogen . . . . .	110
MANUFACTURE :	
General . . . . .	111
By the fractionation of liquid air . . . . .	112
By direct chemical removal of the oxygen from air . . . . .	112
From producer gas and products of combustion . . . . .	114
By physical methods (in the gaseous state) . . . . .	115
By direct chemical methods . . . . .	116
Purification of nitrogen: from carbon monoxide; from carbon dioxide; from oxygen; from sulphur compounds . . . . .	116
Comparison of costs of production and purity attainable by the different processes . . . . .	117
Applications of nitrogen—nitrogen fixation: cyanamide process; the synthesis of ammonia; the formation of metallic nitrides; the direct production of cyanides; the Häusser process; comparison of the power requirements in various nitrogen fixation processes; other applications . . . . .	117
Estimation and testing of nitrogen . . . . .	122
References . . . . .	122

SECTION IV.—THE RARE GASES OF THE  
ATMOSPHERE.

General . . . . .	123
History of the discovery of the rare gases . . . . .	123
ARGON. Occurrence. Manufacture. Properties and applications . . . . .	124
NEON. Occurrence. Isolation. Properties and applications . . . . .	128
HELIUM. Occurrence. Manufacture. Properties and applications . . . . .	130
KRYPTON AND XENON. Occurrence. Isolation and properties . . . . .	132
Niton . . . . .	132
References . . . . .	133

## SECTION V.—OZONE.

Occurrence . . . . .	134
Properties of ozone . . . . .	134
Production of ozone: general; by chemical methods; by thermal treatment of oxygen; by electrolysis; by photochemical means; by the electric discharge . . . . .	136
MANUFACTURE: general principles of ozonizers: influence of the character of the discharge; influence of dielectrics; relation between energy, concentration and production; influence of moisture; influence of temperature; materials of construction. Construction and production of the various commercial types of ozonizers . . . . .	140
Applications of ozone: water sterilization; air purification; chemical applications; other applications . . . . .	145
Detection and estimation of ozone . . . . .	149
References . . . . .	150

## PART II.

HYDROGEN, CARBON MONOXIDE,  
CARBON DIOXIDE, SULPHUR DIOXIDE,  
NITROUS OXIDE, ASPHYXIATING GASES.SECTION VI.—HYDROGEN. STATIONARY  
PLANTS.

Occurrence . . . . .	152
Physical properties. Liquid hydrogen; properties. Chemical properties . . . . .	152
MANUFACTURE (STATIONARY PLANTS):	
General . . . . .	155
From water gas—replacement of carbon monoxide by hydrogen . . . . .	156
B.A.M.A.G. continuous catalytic process: theory of the B.A.M.A.G. continuous catalytic process . . . . .	159
Griesheim-Elektron process: theory of the Griesheim-Elektron process . . . . .	164

MANUFACTURE (STATIONARY PLANTS):— <i>continued.</i>		PAGE
From water gas—by liquefaction of the carbon monoxide: the Linde-Frank-Caro process . . . . .		168
By the action of water or steam on iron or carbon . . . . .		174
General . . . . .		174
Iron oxide processes: Lane process; Messerschmitt process; process of the Internationale Wasserstoff A.G.; Strache process . . . . .		175
Dieffenbach and Moldenhauer process . . . . .		185
Bergius process . . . . .		187
By the decomposition of hydrocarbons: Carbonium Gesellschaft process; Rincker and Wolter process; Oechelhauser process; B.A.M.A.G. (Bunte) process . . . . .		189
By electrolysis . . . . .		194
General. Principal electrolytic processes used in practice: Schuckert process; Schmidt process; Garuti process; Schoop process; International Oxygen Co.'s processes; other processes. Danger limits as regards intermixing in electrolytic hydrogen and oxygen.		
Hydrogen as a by-product . . . . .		194
Other processes for the manufacture of hydrogen . . . . .		203
By the action of acids or alkalis on metals . . . . .		203
Separation from water gas and the like by physical methods . . . . .		204
Through the intermediary of formates . . . . .		205
Miscellaneous methods . . . . .		205
Production of a mixture of nitrogen and hydrogen for use in synthetic ammonia manufacture . . . . .		207
Methods of final purification of hydrogen. From carbon monoxide: by soda-lime; by caustic soda solution; by cuprous chloride solution; by conversion into methane; by calcium carbide. From carbon dioxide. From sulphur compounds. From other impurities . . . . .		207
Comparison of costs of production and purity attainable by the different methods . . . . .		212
Applications of hydrogen: hydrogenation of oils and fats; manufacture of synthetic ammonia; other applications . . . . .		213
References . . . . .		221

## SECTION VII.—THE PRODUCTION OF HYDROGEN FOR MILITARY PURPOSES.

Field processes . . . . .	223
Portable apparatus for use in the field . . . . .	224
Silicon and "Silicol" processes: the Schuckert process; the Silicol process . . . . .	224
Hydrogenite process . . . . .	227
Hydrolith process . . . . .	228
By the action of acids and alkalis on metals: action of sulphuric acid on iron or zinc; action of caustic soda on aluminium; action of activated aluminium on water . . . . .	229
Other processes . . . . .	231

# CONTENTS

XV

	PAGE
Adaptations of stationary types of plant to field purposes . . . . .	232
Semi-portable plant . . . . .	232
Stationary plants . . . . .	233
General: Lifting power of the hydrogen; effect on fabrics; costs by the different processes . . . . .	233
Estimation and testing of hydrogen . . . . .	235
References . . . . .	236

## SECTION VIII.—CARBON MONOXIDE.

Properties of carbon monoxide . . . . .	237
<b>MANUFACTURE:</b>	
Applications of carbon monoxide: general; the Mond nickel process— metallic carbonyls—the refining of nickel by the Mond process; the production of formates, oxalates and acetates; the production of gases rich in methane; the manufacture of phosgene—properties and uses of phosgene; other applications . . . . .	241
Estimation of carbon monoxide . . . . .	254

## SECTION IX.—CARBON DIOXIDE.

Occurrence . . . . .	256
Properties of carbon dioxide; liquid carbon dioxide; solid carbon dioxide	256
<b>MANUFACTURE:</b>	
General . . . . .	259
Generation of pure carbon dioxide . . . . .	259
Utilization of natural sources . . . . .	259
By the thermal decomposition of carbonates . . . . .	260
By the action of acids on carbonates . . . . .	261
Production as a by-product in fermentation processes . . . . .	262
By other methods . . . . .	262
Concentration of carbon dioxide from mixtures with other gases . . . . .	263
By means of water under pressure . . . . .	263
By the alternate formation and decomposition of alkali bicarbonates in solution . . . . .	264
By liquefaction . . . . .	264
Production and concentration of dilute carbon dioxide from products of combustion; Sürth system . . . . .	264
Production and concentration of dilute carbon dioxide from lime-kiln gases . . . . .	267
The production and transport of liquid carbon dioxide . . . . .	268
The production and transport of solid carbon dioxide . . . . .	268
Applications of carbon dioxide: in the Solvay ammonia-soda and the Claus- Chance sulphur recovery processes; in the manufacture of artificial mineral waters; in refrigeration plant; other applications . . . . .	269
Estimation and testing of carbon dioxide . . . . .	272
References . . . . .	273

## SECTION X.—SULPHUR DIOXIDE.

	PAGE
Properties of sulphur dioxide . . . . .	274
<b>MANUFACTURE :</b>	
General . . . . .	275
Production of dilute sulphur dioxide . . . . .	277
Concentration of dilute sulphur dioxide: the Hänisch and Schröder process . . . . .	278
Transport of liquid sulphur dioxide . . . . .	279
Applications of sulphur dioxide: manufacture of sulphuric acid, sulphuric anhydride and sodium sulphate; manufacture of wood pulp; in refrigeration plant; as a solvent; for bleaching purposes; as a disinfectant; other applications . . . . .	280
The estimation and testing of sulphur dioxide . . . . .	283
References . . . . .	284

## SECTION XI.—NITROUS OXIDE.

Properties of nitrous oxide . . . . .	285
<b>MANUFACTURE.</b> From ammonium nitrate; by other methods . . . . .	286
Purification . . . . .	288
Applications of nitrous oxide . . . . .	288

## SECTION XII.—ASPHYXIATING GASES.

Introduction . . . . .	291
The development of gas warfare . . . . .	291

## PART III.

## GASEOUS FUELS.

## SECTION XIII.

General considerations . . . . .	295
Fundamental principles relating to the use of gaseous fuels: table of constants; calorific value; the mechanism of flame; calorific value of technical air-gas mixtures; ignition temperature; explosive limits and the velocity of propagation of explosion . . . . .	296
Fundamental principles of the production of gaseous fuels of low calorific value: action of air on carbon; action of steam on carbon; action of a mixture of air and steam on carbon; action of carbon dioxide on carbon . . . . .	301
<b>TECHNICAL PRODUCTION OF GASEOUS FUELS OF LOW CALORIFIC VALUE :</b>	
Air producer gas . . . . .	313
General. General principles of operation; applications . . . . .	313



# CONTENTS

xvii

	PAGE
Water gas . . . . .	316
General. General principles of operation . . . . .	316
Blue water gas plants; the Lowe system of operation; Dellwik- Fleischer system; Kramer and Aarts process . . . . .	318
Carburetted water gas . . . . .	322
Applications of blue water gas . . . . .	325
Semi-water gas . . . . .	325
General. General principles of operation. Choice of fuel: nitrogen content of coal; sulphur content of coal; other deleterious con- stituents of coal. The saturation temperature of the blast. The rate of gasification . . . . .	325
Semi-water gas plants: general; pressure plants; ammonia recovery and cleaning of semi-water gas . . . . .	335
Mond process . . . . .	339
Use of semi-water gas for furnace operations . . . . .	340
The production of power by the combustion of semi-water gas in gas engines: general; plants for power production; suction plants; use of suction gas in internal combustion engines . . . . .	341
Coal gas as a fuel . . . . .	347
General . . . . .	348
Applications of coal gas: furnace operations; power production; other applications . . . . .	348
Coke-oven gas . . . . .	352
Blast-furnace gas . . . . .	353
Natural gas . . . . .	354
Surface combustion . . . . .	355
Gas calorimetry . . . . .	357
References . . . . .	358
 INDEX OF SUBJECTS . . . . .	 359
 INDEX OF NAMES OF AUTHORS . . . . .	 365

---

## ERRATA

Page 144, line 25, *for 7000 to 9000 volts read 4000 volts.*  
 Page 273, References, *for Goosman read Goosmann.*



# INDUSTRIAL GASES

## INTRODUCTION

THE object of this introductory chapter is to outline and emphasize some of the more important fundamental physical and physico-chemical principles forming the basis of technical gas reactions. In no branch of modern chemistry is the importance of a knowledge of the development of physical chemistry more important than in the study of reactions and phenomena of the gaseous state of matter. This is largely to be attributed to the greater ease of application of generalizations to the gaseous state, owing to its simple physical condition as compared with the liquid and solid states. It is to be feared that many technical gas processes have been worked without due appreciation of the thermodynamical principles determining their success or failure. A most vital factor contributing to this state of affairs is the fact that in many cases, *e.g.* in the coal-gas industry, the responsibility and control are delegated to engineers and not to chemists; at the same time, the engineering aspects of the operations must receive careful consideration.

No attempt will be made in the present volume to give a detailed theoretical treatment of the various physico-chemical generalizations and data to which reference is made; for such information, works on physical chemistry, etc., must be consulted. The intention is rather to draw attention to the salient points of importance in the investigation and control of technical operations relating to the manufacture or utilization of gases.

**Avogadro's Hypothesis.**—This generalization states

that equal volumes of different gases contain equal numbers of molecules under similar conditions of temperature and pressure. As a practical consequence of this law, it may be stated that, to a fairly close approximation, the molecular weight in grams of any permanent gas, *i.e.* a substance above its critical temperature, at  $0^{\circ}\text{C}$ . and 760 mm., occupies 22.38 litres. The volume at  $15^{\circ}\text{C}$ . will consequently be—

$$\frac{22.38 \times 288}{273} \text{ litres} = 23.61 \text{ litres.}$$

A useful figure is the corresponding volume of a pound molecule, which is equal to—

$$\begin{aligned} & 358.5 \text{ ft.}^3 \text{ at } 0^{\circ}\text{C.} \\ \text{or } & 378.2 \text{ ft.}^3 \text{ at } 15^{\circ}\text{C.} \end{aligned}$$

With vapours, *i.e.* gases below their critical temperatures, the volume is usually slightly lower, *e.g.* 22.26 litres at  $0^{\circ}\text{C}$ . and 760 mm. in the case of carbon dioxide.

**Laws of Gay Lussac and Dalton.**—According to these well-known generalizations, chemical combination between gases takes place in definite proportions and the volume of the product or products bears a simple relation to the volumes of the reactants, under like conditions of temperature and pressure. This, of course, is intimately connected with Avogadro's Hypothesis.

**Boyle's Law. Law of Charles and Gay Lussac.**—Boyle's Law states that  $p v = a$  constant, where  $p$  and  $v$  represent the pressure and volume of a given mass of gas, the temperature being maintained constant.

The Law of Charles and Gay Lussac enunciates that the effect of variation of temperature under constant pressure is to vary the volume in direct proportion to the (absolute) temperature variation, or, conversely, if the volume be kept constant, that the pressure varies as the absolute temperature. The combined result of these generalizations may be expressed thus—

$$\begin{aligned} \frac{p v}{T} &= a \text{ constant (K)} \\ \text{or } p v &= K T. \end{aligned}$$

When  $p v$  refers to one gram molecule at N.T.P., the equation is usually written  $p v = RT$ ,  $R$  being termed the gas constant and having a numerical value of 1.98 calories. Since gram molecules are inconvenient units for industrial use, the more general form will be adopted.

This relation, however, is only approximately correct, particularly as regards the constancy of the product  $p v$ , as even the permanent gases are not "perfect"; vapours show very considerable divergencies. Due recognition of this fact is of importance in dealing with compressed gases, and the extent of the deviation from perfection for different gases will be found in Table 12 (A), under the heading of ft.<sup>3</sup> of free gas contained in a cylinder of 1 ft.<sup>3</sup> capacity at a pressure of 120 atmospheres, 121 atms. absolute. The values are obtained as follows:—*e.g.*, in the case of hydrogen, the variation of the product  $p v$  with  $v$  at a temperature of 15.5° C. is—

TABLE I.  
AMAGAT. COMPRESSIBILITY OF HYDROGEN.

$p$ (atmospheres absolute)	1	50	100	150	200
$p v$ . . . . .	1	1.0340	1.0689	1.1011	1.1342
$p/p v$ . . . . .	1	48.36	93.56	136.23	176.34

(*cf.* Amagat, *Annales de Chim. et de Phys.*, [6], 29, (1883), 68).

The ratio  $\frac{p}{p v}$  represents the ratio of the mass of gas (or the volume of free gas) contained in a given reservoir at the particular absolute pressure to that at one atmosphere absolute pressure, assuming no change in the volume of the container. The curves in Fig. 1 give the variation of  $p v$  with  $p$  for a number of permanent gases. Most of the values are taken from Amagat's investigations (*Annales de Chim. et de Phys.*, [5], 19, (1880), 345; [5], 22, (1881), 353; [6], 29, (1883), 68, 505) and have been arranged in all cases so that the product  $p v$  equals unity at 0° C. at atmospheric pressure; at the particular temperature of the determination the product is greater in accordance with the coefficient of expansion of the gas in question. In the case of oxygen,

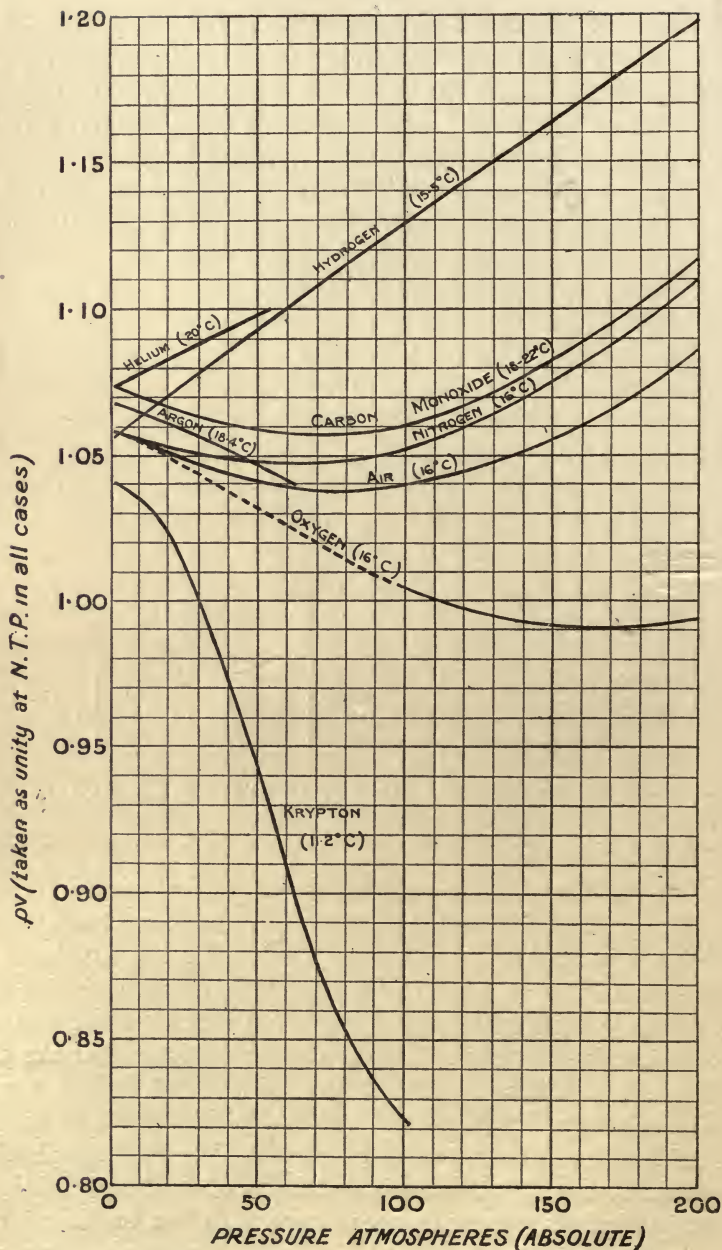

FIG. 1.—Compressibility of Gases at the ordinary Temperature.

only three points are available, namely, 1, 100, and 200 atms., consequently the intermediate points of the curve are a little uncertain.

The capacity of a given cylinder at the (absolute)

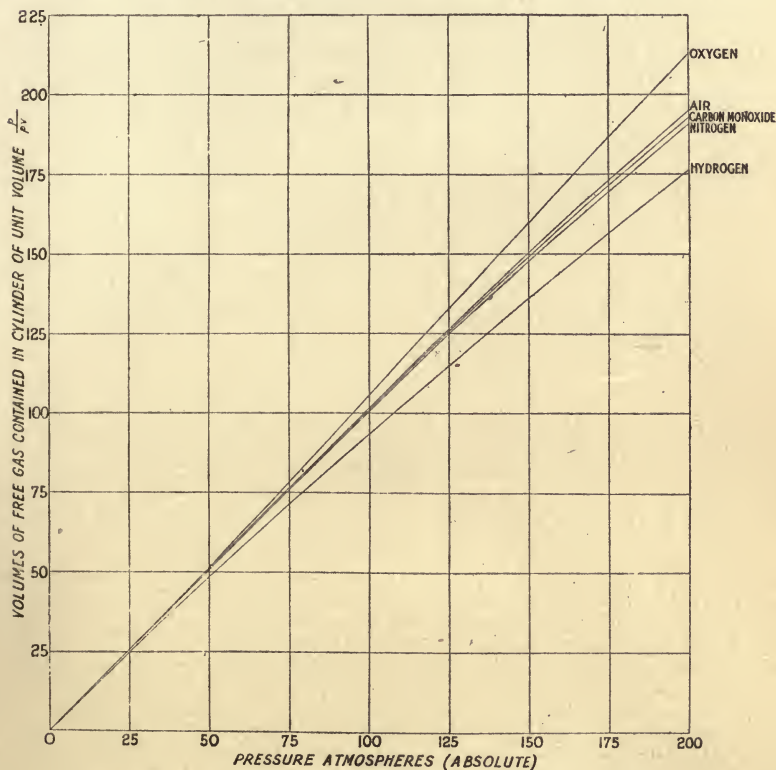

FIG. 2.—Capacity of Cylinder for Compressed Gases.

pressure  $p_x$  can readily be determined from these curves by evaluating the expression—

$$p \frac{(pv)_1}{(pv)_x}$$

where  $(pv)_1$  and  $(pv)_x$  represent the values at the pressures of one and  $p_x$  atmospheres respectively. Curves on this basis have been plotted in Fig. 2, the ordinates representing the volumes of free gas contained in a given cylinder at the pressures denoted by the abscissæ.

This variation in the value of  $pv$  is due to the joint action of two opposing factors: (1) the attraction between the molecules, acting in the direction of lowering the product  $pv$ , and (2) the departure from perfect compressibility owing to the actual dimensions of the molecules, operative in the opposite direction. Thus, nitrogen at first shows a decrease in the product  $pv$  with rising pressure and subsequently an increase. In order to allow for the very considerable divergence from Boyle's Law, even at moderate pressures, of gases such as carbon dioxide, various more complete equations have been proposed. The growing imperfection of air as the temperature is lowered is well shown by the measurements of Witkowski (*Phil. Mag.*, [5], 41, (1896), 288), given in Table 2. The values are taken so that  $pv = 1.000$  at N.T.P., as in Fig. 1.

TABLE 2.  
WITKOWSKI. COMPRESSIBILITY OF AIR.

Pressure atms.	Temperatures °C.									
	+100	+16	0	-35	-78.5	-103.5	-130	-135	-140	-145
1	1.367	1.0587	1.0000	0.8716	0.7119	0.6202	0.5229	0.5046	0.4862	0.4679
10	1.3678	1.0550	0.9951	—	—	—	—	—	—	—
15	1.3685	1.0529	.9923	—	—	—	—	—	.4095	.3786
20	1.3691	1.0509	.9897	—	.6778	.5697	.4410	—	.3808	.3447
25	1.3698	1.0488	.9869	—	.6689	.5559	.4183	—	.3476	.3015
30	1.3704	1.0468	.9842	—	.6599	.5417	.3936	.3502	.3063	.2444*
35	1.3713	1.0449	.9816	—	.6510	.5270	.3650	.3115	.2419	—
40	1.3725	1.0433	.9793	—	.6423	.5125	.3329	.2598	.1128	—
45	1.3738	1.0419	.9772	—	.6335	.4980	.2963	.1942	—	—
50	1.3754	1.0408	.9754	.8288	.6252	.4839	.2544	.1605	—	—
55	1.3770	1.0399	.9738	.8253	.6170	.4701	.2171	.1553	—	—
60	1.3784	1.0390	.9723	.8219	.6089	.4567	.2013	.1556	—	—
65	1.3802	1.0384	.9710	.8187	.6011	.4439	.1985	.1576	—	—
70	1.3821	1.0381	.9701	.8158	.5937	.4318	.1989	—	—	—
75	1.3842	1.0379	.9694	.8132	.5863	.4206	.2013	—	—	—
80	1.3866	1.0379	.9688	.8105	.5796	.4103	.2043	—	—	—
85	1.3887	1.0380	.9684	.8081	.5734	.4014	—	—	—	—
90	1.3908	1.0382	.9681	.8058	.5680	.3948	—	—	—	—
95	1.3929	1.0386	.9680	.8038	.5634	.3903	—	—	—	—
100	1.3951	1.0390	.9681	.8023	.5600	.3881	—	—	—	—
105	1.3977	1.0397	.9685	.8013	.5568	.3874	—	—	—	—
110	1.4004	1.0406	.9690	.8006	.5544	.3877	—	—	—	—
115	1.4034	1.0418	.9699	.8004	.5530	.3892	—	—	—	—
120	1.4065	1.0432	.9710	.8006	.5520	.3914	—	—	—	—
125	—	1.0448	.9722	.8012	.5520	.3944	—	—	—	—
130	—	1.0467	.9738	—	.5528	.3981	—	—	—	—

\* Corresponds to 29 atms.



In the more complete equation of Van der Waals—

$$\left( p + \frac{a}{v^2} \right) (v - b) = KT$$

the quotient of the constant  $a$  divided by  $v^2$  representing the cohesion effect, and  $b$ , another constant, representing the actual dimensions of the molecules, the constants may be evaluated by the following expressions:—

$$a = \frac{27K^2T_c^2}{64p_c} = \text{approximately } \frac{27p_o^2v_o^2T_c^2}{64p_cT_o^2}$$

$$b = \frac{KT_c}{8p_c} = \text{approximately } \frac{p_ov_oT_c}{8p_cT_o}$$

where

$T_c$  and  $p_c$  are the critical temperature and pressure,  
 $p_o$  and  $v_o$  represent the pressure and volume of the  
 gas at the absolute temperature  $T_o$ ,

and  $K$  is a constant.

The value of this equation in correlating the very different behaviour of various gases under varying conditions of temperature and pressure is well seen if the equation is written in the following form, substituting the above values for  $a$  and  $b$ —

$$\left( \pi + \frac{3}{\phi^2} \right) (3\phi - 1) = 8\theta$$

where  $\pi$ ,  $\phi$  and  $\theta$  represent the multiples or submultiples of the critical values, pressure, volume\* and temperature, respectively. If, now, we plot  $\pi\phi$  curves instead of  $p v$  curves we obtain practically identical curves for all gases; for equal values of  $\pi$ ,  $\phi$  and  $\theta$  two gases are said to be in corresponding states.

This and other equations, *e.g.* that of Dieterici, give closer but still incomplete agreement with experimental results.

**Absolute Zero of Temperature.**—According to the Law of Gay Lussac and Dalton, which may be expressed—

$$v = \frac{KT}{p}$$

\* The critical volume of the mass of gas under consideration is the volume at the critical temperature and pressure.

the volume of a gas should become equal to zero when  $T=0$ .

The observed coefficient of expansion of gases, *i.e.* about  $\frac{1}{273}$  of the volume at  $0^{\circ}$  C. per  $^{\circ}$  C., indicates that the absolute zero of temperature, *i.e.* the temperature at which the molecules have ceased to have relative motion, is approximately  $273^{\circ}$  C. below the freezing point of water. More exact computations, *e.g.* from the Joule-Thomson effect (see below), indicate a probable value of  $-273.13^{\circ}$  C.

**Solution: Henry's Law; Dalton's Law.**—It was shown by Henry that the solubility of a gas is proportional to its pressure, and by Dalton, shortly afterwards, that with gaseous mixtures the solubility of each constituent in a liquid is proportional to the partial pressure of the constituent, the other gases behaving as a vacuum. Like many other "laws," these generalizations are only approximately correct, especially for a gas with a high degree of solubility.

The principle of partial pressures applies to many processes besides that of solution, *e.g.* the temperature at which a particular constituent of a gaseous mixture will liquefy out as the temperature is progressively lowered is dependent on its partial pressure. Generally speaking, it may be stated that the solubility of gases in water falls off as the temperature is raised; with other solvents, however, this is not always the case.

**Sorption.**—When gases are taken up by solids, the phenomena are much less simple. It becomes necessary to differentiate between absorption, *i.e.* solution or uniform distribution throughout the structure of the solid, and adsorption, which is essentially a surface condensation. The combined effect is sometimes termed sorption. Thus, when hydrogen is brought into contact with charcoal at liquid-air temperatures, there is a rapid fall in pressure occupying only a few minutes, attributed to adsorption, followed by a slow fall over several hours, considered by McBain (*Z. physik. Chem.*, **68**, (1909), 471) to be a slow penetration into the structure of the charcoal. Similar

effects were observed by Richardson (*J. Amer. Chem. Soc.*, **39**, (1917), 1828) in the sorption of carbon dioxide and ammonia by charcoal. In some cases there is evidence of the formation of a chemical compound, *e.g.* with oxygen and charcoal (Rhead and Wheeler, *Chem. Soc. Trans.*, (1913), 641). In adsorption phenomena, the relation between pressure and the extent to which the gas is taken up is much more complex than in ordinary solubility.

Gases are taken up in appreciable quantities by many metals, in the solid and especially in the liquid state, the sorption usually increasing with the temperature; at the fusion point there is a sudden increase in the sorption in the case of most metals. Thus, metallic iron takes up 0.000035% by weight of hydrogen at 416° C. and 0.000108% at 1450° C. (Jurisch, *Stahl und Eisen*, **34**, (1914), 252). Between 23 and 750 mm. the weight of hydrogen absorbed varies as the square root of the pressure for a given allotropic modification of the iron. With nitrogen, the sorption by weight is 0.00158% at 878° C., 0.02103% at 981° C., falling off to 0.01885% at 1136° C., the amount varying as the square root of the pressure (Jurisch, *l.c.*).

**Diffusion.**—The diffusion of one gas into another takes place with considerable rapidity under ordinary conditions. The rate is inversely proportional to the total pressure of the two gases, and approximately proportional to the square root of the absolute temperature. The effect of increased pressure is very noticeable if a mixture of two gases, *e.g.* nitrogen and hydrogen, be made by successive compression of the two gases into a cylinder, particularly if the cylinder be in a vertical position, and the lighter gas be introduced second. If, however, the cylinder be disposed in a horizontal position, diffusion is almost complete on standing 12 to 24 hours.

It is interesting to note that diffusion is scarcely affected by the presence of a perforated partition, although the aggregate area of communication may be greatly reduced.

**Permeability of Materials.**—A point of some practical importance, in dealing with gases, is the permeability of

materials. Thus, hydrogen diffuses through heated palladium or platinum and to a lesser degree through heated iron. Quartz is appreciably permeable to hydrogen above  $1000^{\circ}$  C., while indiarubber is fairly permeable to gases. According to Dewar (*Proc. Roy. Institution*, **21**, (1918), 813) the rate of diffusion of various gases at  $15^{\circ}$  C. and 760 mm. pressure through a rubber membrane of 0.01 mm. thickness is as follows :—

TABLE 3.  
RATES OF DIFFUSION THROUGH RUBBER.

Gas.	Air	Nitrogen	Carbon monoxide	Helium	Argon	Oxygen	Hydrogen	Carbon dioxide
Rate of diffusion cm. <sup>3</sup> /cm. <sup>2</sup> /diem.	2.0	1.38	1.88	3.5	2.56	4.0	11.2	28.0

The rate of diffusion increases rapidly with temperature but does not appear to be directly related to any chemical or physical property of the different gases. When dealing with mixtures of gases, it is obvious that the effect of such diffusion will be to produce a change in composition.

**Critical Temperature and Pressure.**—*Permanent Gases and Vapours.*—It was found by Andrews that for each gas there is a certain temperature above which it is impossible to effect liquefaction by simple compression, however great. This temperature is termed the critical temperature, and the pressure of the system at this point, *i.e.* the pressure required to effect liquefaction at the critical temperature, is termed the critical pressure. The values of the critical pressures are comparatively low and fall off as the value of the critical temperature decreases; thus, for hydrogen, the critical pressure is only about 11 atmospheres.

**Joule-Thomson Effect.**—If a compressed gas be allowed to expand to a lower pressure through an orifice without the production of external work, there is, as was observed by Joule and Thomson, a certain slight cooling effect with most gases. With a perfect gas there should be no change in temperature; the observed effects are therefore due to

deviations from Boyle's and Joule's Laws, Joule's Law stating that—

$$U = \text{the internal energy of the gas} = KT$$

where K is a constant and T the absolute temperature.

The cooling effect is due mainly to the work of separation of the molecules and will, therefore, be greater as the temperature of the gas is lowered; similarly the effect will be greater with gases which are not much above or are below their critical temperatures. Thus, the effect is much greater for carbon dioxide than for air, while with hydrogen a heating effect is actually observed (*cf.* p. 67). On lowering the temperature of the hydrogen, however, an inversion point is reached at  $-80.5^{\circ}$  C. It was found by Joule and Thomson that the fall in temperature could be represented by the expression—

$$\Delta T = \frac{A}{T^2} (p_1 - p_2)$$

where  $\Delta T$  = the fall in temperature in degrees Centigrade and A = a constant,

while according to the more exact formula of Rose-Innes (*Phil. Mag.*, 45, (1898), 227)—

$$T = (p_1 - p_2) \left( A - \frac{B}{T} \right)$$

where A and B are constants. The latter formula indicates the existence of an inversion point.

The Joule-Thomson effect forms the basis of the Linde process for the liquefaction of air and is dealt with more fully on p. 61.

**Specific Heats of Gases.**—The specific heats of gases will be found to be of fundamental importance in many questions of plant design as well as in thermodynamical calculations. The specific heat of a gas varies according as to whether the rise or fall in temperature takes place at constant pressure or at constant volume, *i.e.* with or without the performance of external work, against the atmosphere. The former,  $C_p$ , is, of course, greater than the latter,  $C_v$ , the

difference being constant and equal per gram molecule of gas to  $R$ , the gas constant,  $R$ , being also expressed in calories per gram molecule of gas.

Thus—

$$C_p - C_v = R = 1.98 \text{ calories}$$

where  $C_p$  and  $C_v$  are the molecular heats.

It is often convenient in plant design to express thermal quantities in terms of pounds and degrees Centigrade and to denote the resulting units as C.H.U. (Centigrade heat units), this procedure having many advantages over the B.T.U. system using lbs. and degrees Fahrenheit. It should be noted that  $1 \text{ C.H.U./lb.} = 1 \text{ calorie/gram} = 1 \text{ kilocalorie/kilo.}$

Further, as the heat capacities of most diatomic gases for equal volumes are equal to within, say, 15 %, it is often convenient to express the same in terms of C.H.U./1000 ft.<sup>3</sup>/°C. Thus—

The specific heat at constant pressure of air at 20° C.

$$= 0.2417 \text{ cal./gram.} = 0.2417 \text{ C.H.U./lb.}$$

$$= 0.2417 \times 76.49 \text{ C.H.U./1000 ft.}^3\text{/}^\circ\text{C. at } 15^\circ \text{ C.}$$

$$= 18.49 \text{ C.H.U./1000 ft.}^3\text{/}^\circ\text{C.}$$

It is important to note that in many cases the specific heats of gases vary very considerably with temperature and pressure. The effect of increased temperature in general is to produce a slow increase in the specific heat; at very low temperatures, however, approximating to the point of liquefaction of the particular gas, there is a sudden and very marked increase in the specific heat.

The effect of increased pressure is also to produce an increase in the specific heat, thus, the specific heat at constant pressure of air increases from 0.2415 at 1 atmosphere to 0.2925 at 200 atmospheres (Holborn and Jakob, *Z. Verein. deut. Ing.*, **58**, (1914), 1429), an increase of 21 %. The very high pressure coefficients found by Lussana (*Cim.*, [3], **36**, (1894), 5, 70, 130) are undoubtedly incorrect. It has been found that the ratio  $C_p/C_v$  is a constant for gases containing the same number of atoms in the molecule. The approximate value for monatomic gases, e.g. argon,

mercury vapour, etc., is 1.666, for diatomic gases, *e.g.* nitrogen, 1.41, and for triatomic gases, *e.g.* carbon dioxide, 1.30. This ratio, usually denoted by  $\gamma$ , is of importance in connection with adiabatic compression, and with the propagation of sound in gases, etc.

**Latent Heats of Vaporization and Fusion.**—When dealing with the liquefaction or solidification of gases, a knowledge of the quantities of heat required to effect the change in question is necessary. Particularly is the thermal change demanded by the condensation and vaporization of gases important in connection with the production of cold by mechanical means, *e.g.* through the intermediary of ammonia or carbon dioxide. The values of the latent heats of vaporization of substances decrease with rise in temperature.

**Thermochemistry.**—In connection with plant design, an important question is that of the thermochemical quantities concerned in the different reactions, and, in the case of new processes, it may be necessary to make special determinations of the same. When dealing with simple combustion, this can be easily effected by means of the Junker calorimeter (*cf.* p. 357) or other like instrument; if the gas undergoing combustion contains hydrogen, the heat of combustion may be expressed in two ways: (1) gross, *i.e.* including the latent heat of vaporization of the water formed, or (2) nett, in which case this quantity is deducted. The latent heat of vaporization of water at 15° C. is about 590 C.H.U./lb., or 10,600 C.H.U./lb. molecule.

It is sometimes the custom in English technical practice to consider the water as separated at 100° C. with the heat evolution of 538 C.H.U./lb. water and to deduct this quantity plus the heat capacity of the water down to ordinary atmospheric temperature (60°F. = 15.5° C.), equivalent in this case to 84.5 C.H.U./lb. water, making a total of 622.5 C.H.U./lb. water (1120 B.T.U.).

In French practice, the latent heat alone, *i.e.* 538 C.H.U., is deducted.

Of course, neither of these procedures has a very precise significance.

An accurate knowledge of the heats of reaction is also of fundamental importance in connection with calculations of gas equilibria.

**Thermodynamical Principles Governing Chemical Equilibria in the Gaseous State.**—It is often of considerable importance to be able to make an approximate forecast of the course which will be followed by a reversible gas reaction of which the equilibrium data have not been determined. To take an example, consider the reaction represented by the following equation—

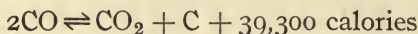

and suppose it is required to know without further data, what equilibrium would be set up at a temperature of  $800^\circ \text{C}$ . under atmospheric pressure, assuming the presence of an adequate catalyst and sufficient time for the attainment of equilibrium.

The theoretical solution, largely due to Nernst, requires more space than can be allotted in the present volume. It may be stated, however, that Nernst deduced the following formula—

$$\log K = \frac{Q_0}{4.571T} + \Sigma \nu_i \cdot 75 \log T + \frac{\Sigma \nu B}{4.571} + \Sigma \nu C \quad (1)$$

applying to an equation such as—

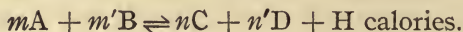

If, for the sake of simplification, we adopt the convention that the heat of reaction,  $Q$ , is taken as that written on the same side of the equation as the substances occurring in the numerator of the fraction representing  $K$ , *e.g.* in the above instance,  $Q_T = \text{H}$  when—

$$K = \frac{p_C^n \times p_D^{n'}}{p_A^m \times p_B^{m'}}$$

$p_A$  representing the partial pressure in atmospheres of the constituent A in the final equilibrium, and similarly for B, C, and D.

$$\begin{aligned} \text{Then } Q_0 &= \text{heat of reaction at absolute zero} \\ &= Q_T - \Sigma \nu 3.5 T - \Sigma \nu \beta T^2 \quad \dots \quad (2) \end{aligned}$$



$\Sigma v$  = the algebraic sum of the volumes, those on the right being taken as positive and those on the left as negative,

T = the absolute temperature,

$$\Sigma v\beta = \frac{\Sigma vH_p - \Sigma v3.5}{2T}$$

( $H_p$  being the molecular heat of each constituent at temperature T), and

$\Sigma vC$  = the algebraic sum of the chemical constants corresponding to each volume of gas participating in the reaction, those on the right being taken as positive, those on the left as negative.

For most purposes, however, it is permissible to neglect the terms correcting for the effect of temperature on Q (equation (2)), and to omit the third term in (1), especially as the data for such refinements are, in many cases, lacking.

We then have—

$$\log K = \frac{Q}{4.571T} + \Sigma v1.75 \log T + \Sigma vC \quad (3)$$

where Q = heat of reaction at the ordinary temperature.

If one or more constituents be solid or liquid with no appreciable vapour pressure, *e.g.* carbon in the above example, the pressures of these constituents do not appear in the fraction representing K, and the chemical constants are not included in the term  $\Sigma vC$ .

When no change in volume occurs during the reaction, the term  $\Sigma v1.75 \log T$  disappears.

*The Chemical Constant.*—The undetermined integration constant, known as the chemical constant, can be evaluated by considerations into which it is unnecessary to enter here, and values as follows are obtained for the different gases (*cf.* also Langen, *Z. Elektrochem.*, **25**, (1919), 25) :

TABLE 4.  
CHEMICAL CONSTANTS.

Gas.	Chemical Constants.
Hydrogen . . . . .	1·6
Methane . . . . .	2·5
Nitrogen . . . . .	2·6
Oxygen . . . . .	2·8
Carbon monoxide . . . . .	3·5
Chlorine . . . . .	3·1
Iodine . . . . .	3·9
Hydrochloric acid . . . . .	3·0
Hydriodic acid . . . . .	3·4
Nitric oxide . . . . .	3·5
Nitrous oxide . . . . .	3·3
Sulphuretted hydrogen . . . . .	3·0
Sulphur dioxide . . . . .	3·3
Carbon dioxide . . . . .	3·2
Carbon disulphide . . . . .	3·1
Ammonia . . . . .	3·3
Water . . . . .	3·6
Carbon tetrachloride . . . . .	3·1
Chloroform . . . . .	3·2
Benzene . . . . .	3·0
Ethyl alcohol . . . . .	4·1
Ether . . . . .	3·3
Acetone . . . . .	3·7
Propyl alcohol . . . . .	3·8

Returning to the equation in question, and substituting the appropriate values in the expression—

$$\log K = \frac{Q}{4.571T} + \sum \nu 1.75 \log T + \sum \nu C$$

we have—

$$\begin{aligned} \log \frac{p_{\text{CO}_2}}{p_{\text{CO}}^2} &= \frac{39,300}{4.571 \times 1,073} - 1.75 \log 1,073 + (3.2 - 2 \times 3.5) \\ &= 8.013 - 5.304 - 3.8 \\ &= -1.091 \end{aligned}$$

therefore

$$K = 0.0811$$

Boudouard's experimental value for this temperature was 7% carbon dioxide, *i.e.*—

$$K = \frac{p_{\text{CO}_2}}{p_{\text{CO}}^2} = \frac{0.07}{0.93^2} = 0.0809$$

representing a satisfactory agreement, the closeness of which is accidental. In most cases, the agreement is considerably less good but a valuable, if approximate, idea of the equilibrium may be obtained in this way.

**Velocity of Reaction.**—The velocity of chemical reaction is very sensitive to changes in temperature, and, as a rough average rule, it may be taken that the velocity doubles itself with each  $10^\circ$  C. rise in temperature.

Further, the concentrations of the reactants are operative as follows, *e.g.* in the homogeneous bimolecular reaction—

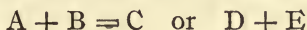

if  $a$  and  $b$  are the initial molar concentrations of A and B, and  $x$  the amount of either which has undergone combination at time  $t$ , then—

$$\frac{dx}{dt} = k_T(a - x)(b - x)$$

where  $k_T$  is a constant for temperature T.

**Heterogeneous Catalytic Gas Reactions.**—*Reaction Velocity—Output and Completeness.*—By heterogeneous catalysis it is implied that there is a discontinuity between the reactants and the catalyst. Nearly all the important cases of technical gas catalysis belong to this category.

In most heterogeneous catalytic gas reactions, *e.g.* in the direct synthesis of ammonia, we are dealing with the dual effects of equilibrium and reaction velocity. Thus, on working with a fixed pressure and a moderate gas flow, and gradually raising the temperature from, say,  $300^\circ$  C. to  $900^\circ$  C., we find the percentage of ammonia in the effluent gases increases from practically zero to a maximum value in the region of  $500$ – $600^\circ$  C. (the exact temperature depending on the catalyst and the rate of flow), and then falls off again. At  $900^\circ$  C., even with an indifferent catalyst, equilibrium—about 0.7%  $\text{NH}_3$  at 100 atmospheres—is almost completely established, whereas at a low temperature, such as  $300^\circ$  C., although the equilibrium value is some 52% at 100 atmospheres, the reaction velocity is so low that practically no ammonia formation takes place. This example is typical of the phenomena occurring in heterogeneous catalytic reactions.

Another important point in the control of heterogeneous catalytic gas reactions is the relation between the velocity

of passage of the reacting gases over the catalyst, the rate of formation of the product, and the volume occupied by the catalyst. It will be found convenient to denote the ratio of gas velocity per hour to the gross catalyst volume by "space-velocity," and the ratio of the production per hour to the gross catalyst volume by "space-time-yield." Using these terms we find that as the space-velocity is increased there is often a steady increase in the space-time-yield, although the approach to equilibrium in the reaction products falls off. Thus, taking again the case of ammonia, as the space-velocity is increased the percentage of ammonia falls off but the production per unit time increases (cf. p. 215). This is important as the output of a plant is thereby raised, although this, of course, is not the only practical consideration.

For a proper understanding of these phenomena it will be necessary to examine the facts a little more closely, and to study the progress of such reactions with time. In an investigation of the catalytic reaction—

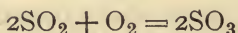

Bodenstein and Fink (*Z. physik. Chem.*, **60**, (1907), 1, 45) found that the rate of reaction was practically independent of the concentration of oxygen, was proportional to the concentration of the sulphur dioxide and inversely proportional to the square root of the concentration of the sulphur trioxide—

$$\frac{dx}{dt} = k \frac{(a - x)}{x^{\frac{1}{2}}}$$

where  $a$  is the initial concentration of the sulphur dioxide and  $x$  is the concentration of the sulphur trioxide, *i.e.* we have a modified monomolecular reaction, whereas, according to the laws governing homogeneous reactions, it should be termolecular.

This behaviour was explained by Bodenstein on the so-called "diffusion theory," which supposes reaction on the surface of the catalyst to be extremely rapid but that access of the reactants thereto can only occur by diffusion through

an adsorbed film of the reaction product—in this case, sulphur trioxide. The rate of reaction, therefore, is dependent on the rate of diffusion of the component with the lower coefficient of diffusion, namely, sulphur dioxide, unless a sufficient excess of this gas be present when the rate of diffusion of the oxygen begins to play an appreciable part. In dealing with such reactions it is difficult to formulate any general rules as to the reaction kinetics; thus, in the reaction—

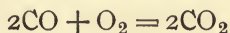

Bodenstein and Ohlmer (*Z. physik. Chem.*, **53**, (1905), 166) found that the rate of reaction was, roughly, inversely proportional to the concentration of the carbon monoxide, a case of negative catalysis.

In the case of the catalytic combination of the constituents of electrolytic gas, Bone and Wheeler (*Phil. Trans.*, A, **206**, (1906), 1) found—

$$k = \frac{1}{t} \log \frac{C_{0\text{H}_2}}{C_{t\text{H}_2}}$$

where  $C_{0\text{H}_2}$  and  $C_{t\text{H}_2}$  are the concentrations of hydrogen at the beginning and at time  $t$  respectively; this observation is not in accordance with the requirements of the diffusion theory, which demands that the rate should be proportional to some function of the oxygen concentration, this being the gas of slower rate of diffusion.

Taking again the example of ammonia synthesis, a mental picture of the effect of velocity of passage of the gases over the catalyst may be formed as follows: imagine the speed of passage to be suddenly increased; if we assume the rate of diffusion of the reactants through the ammonia film to remain constant momentarily, the rate of production will be unaltered and the percentage of ammonia in the gases will fall off. The thickness of the film, being a function of the concentration of the ammonia, will now diminish as a result and thus permit the production to rise. The degree of turbulence of the gas current will exert a certain influence by its effect in reducing "pocketing" and consequent local formation of thick ammonia films.

Similar considerations apply to any reaction in which a solid catalyst is used to promote the combination of gaseous substances; in some cases the point of importance is not the hourly quantity of the resulting product or products, but the closeness with which equilibrium is approached, *e.g.* in the B.A.M.A.G. continuous catalytic hydrogen process (cf. p. 159) the elimination of carbon monoxide is the most important consideration, being balanced by the desirability of treating a given volume of gas in the least possible catalyst space.

In catalytic operations the question of catalyst surface is of great importance, the output of a given gross volume being enhanced by the increase of the surface of the catalyst, *e.g.* by subdivision of the catalyst mass, although the increased resistance set up thereby makes a compromise necessary. Calvert, in B.P. 10612/12, suggests increasing the rate of catalysis by whirling the catalyst inside a closed vessel traversed by the gas current, also Walter, in D.R.P. 295507/17, proposes to agitate the catalyst grains by magnetic means. In each case the gain in output is secured without the usual disadvantage of increased dilution, or, conversely, a close approximation to equilibrium is facilitated without the necessity for such slow passage of the gases. The application of such ideas, however, is not very easy in practice, and in the case of the magnetic agitation, the mutual attrition of the catalyst grains would be prejudicial.

In the patent literature relating to catalysis considerable attention has been paid to the question of electrostatic activation of catalysts, but nothing of practical importance would appear to have been evolved in this direction.

**Viscosity of Gases—Stream-Line and Turbulent Motion.**—When a gas (or other fluid) flows through a conduit under certain conditions—see below—the gas moves at a higher velocity in the centre than in the layers nearer the walls, while the layer contiguous to the walls is stationary.

Viscosity is defined as the tangential force exerted per unit area between two layers in the fluid 1 cm. apart,

when the difference in velocity is 1 cm./sec. For flow through a tube, the viscosity ( $\mu$ ) is given approximately by the expression—

$$\mu = \frac{\pi p r^4 t}{8 l V}$$

where  $p$  = the pressure drop in dynes/cm.<sup>2</sup>,

$r$  = radius of tube in cms.,

$t$  = time in seconds required for the passage of  $V$  c.c. of fluid (measured at the mean pressure),

$l$  = length of the tube in cms.

The viscosity of gases increases considerably with rise in temperature, cf. Table 12 (c).

An interesting fact is that the viscosity of gases is approximately independent of the pressure, *i.e.* the *volume* of gas at, say, 200 atmospheres pressure, flowing through a given tube with a certain pressure drop will be approximately the same per unit of time as that observed for an equal pressure drop with gas at atmospheric pressure; the *weight* of gas, however, will be some 200 times as great.

The above observations hold only for stream-line motion through conduits, *i.e.* in the complete absence of turbulence. When a fluid passes through a straight smooth circular tube, the motion remains of the stream-line type until a certain definite velocity—known as the critical velocity—is reached, when turbulence sets in abruptly and increases steadily in degree as the velocity is further increased. The pressure drop increases sharply with the inception of turbulence and is no longer defined by the expression just given, being now determined by the surface friction.

The critical velocity is given by the following expression—

$$v_c = \frac{2500\mu}{d\rho} \text{ cm./sec.}$$

where  $\mu$  = the viscosity of the fluid in C.G.S. units,

$d$  = diameter of the tube in cms.,

$\rho$  = the density of the fluid in grams/cm.<sup>3</sup>,

$v_c$  = the critical velocity (mean linear velocity) in cm./sec.,

*i.e.*  $v_c$  is directly proportional to the viscosity of the fluid and inversely proportional to the diameter of the tube and to the density of the fluid. This applies generally to all fluids (cf. Stanton and Pannell, *Phil. Trans.*, A., **214**, (1914), 199).

In some cases it may be more convenient to express partly in terms of British units, thus—

$$v_c = \frac{2000\mu}{\rho d} \text{ ft./sec.}$$

or

$$Q_c = 40,000 \frac{\mu d}{\rho} \text{ ft.}^3/\text{hr.}$$

where  $v_c$  = critical velocity (mean linear velocity) in ft./sec.,

$\mu$  = viscosity in C.G.S. units,

$\rho$  = density of the fluid in lbs./ft.<sup>3</sup>,

$d$  = diameter of the tube in inches,

$Q_c$  = the minimum gas flow, measured at the temperature and pressure used, at which turbulent motion obtains, in ft.<sup>3</sup>/hr.

It must not be imagined that the flow in a given conduit is necessarily stream-line motion because the velocity is below that given in the above formula; unstable turbulence may be set up by local irregularities, bends, etc. The turbulence will die away, however, if sufficient time be allowed and the re-establishment of stream-line motion may be accelerated by the insertion in the stream of a series of perforated grids.

**Resistance to Flow of Gases.**—In technical gas manufacture and usage, the calculation of the pressure drop in a given pipe-line is an important point, the resistance to flow often constituting the source of a considerable power expenditure. The following formula gives fairly good results for turbulent motion in smooth, straight, circular pipes (cf. Newbiggin's "Handbook for Gas Engineers and Manufacturers": London, 1913, p. 276):—

$$dp = \frac{Q^2 \rho L}{11 \times 10^6 \times d^5} \text{ lbs./in.}^2$$



where  $Q = \text{ft.}^3/\text{hr.}$  of gas, measured at the temperature and pressure in question, passing through the tube,

$\rho = \text{density of the gas in lbs./ft.}^3$

$L = \text{length of the tube in feet,}$

$d = \text{diameter in inches.}$

The formula assumes that the pressure drop is proportional to the square of the linear velocity, which assumption is not strictly correct especially as no account is taken of the state of turbulence or otherwise of the fluid. Thus, with stream-line motion the pressure drop is proportional to the first power of the linear velocity. A more exact treatment is furnished by an experimental investigation by Stanton and Pannell (*loc. cit.*) giving rise to a general curve which connects—

$$\frac{R}{\rho V^2} \text{ and } \log \frac{2Vr\rho}{\mu} = \log \frac{2Q\rho}{\pi r\mu} \quad (\text{Fig. 3})$$

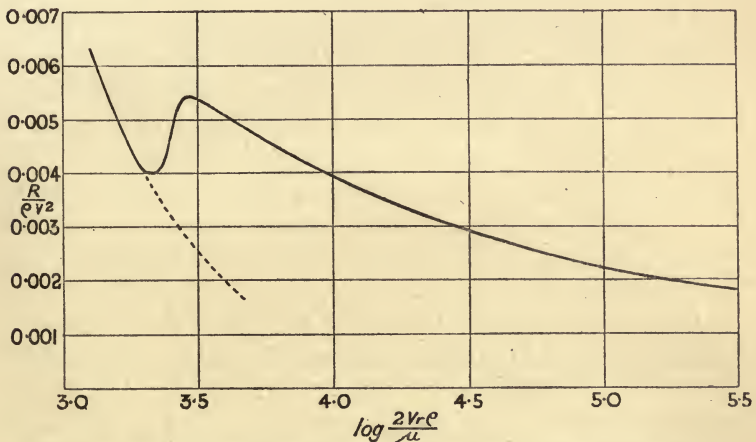

FIG. 3.—Stanton and Pannell's Surface Friction Determinations.

and covers the whole range, including the transition from stream-line to turbulent motion, and, moreover, is applicable to all fluids, whether liquid or gaseous.

$R = \text{resistance per unit area of the internal surface of the circular tube,}$

$\rho = \text{density of the fluid,}$

$V$  = mean linear velocity,

$r$  = radius of tube,

$\mu$  = viscosity of the fluid,

all in absolute units.

The pressure drop in a given circular tube is given by the expression—

$$dp = \frac{2\rho Q^2 l C}{\pi^2 r^5} \text{ dynes/cm.}^2 = \text{approximately } \frac{2\rho Q^2 l C}{10^6 \pi^2 r^5} \text{ atms.}$$

where  $\rho$  = density of the fluid in grams/cm.<sup>3</sup>

$Q$  = flow through the tube in cm.<sup>3</sup>/sec.

$V$  = mean linear velocity of the fluid in cm./sec.

$l$  = length of tube in cms.

$r$  = radius of tube in cms.

$C$  =  $R/\rho V^2$  as read off from the curve (Fig. 3).

$\mu$  = viscosity of the fluid in C.G.S. units.

The above observations apply only to smooth and straight circular conduits. The effect of abrupt bends, valves, local constrictions, and also of enlargements in the section of the pipe is to introduce large effects which may be equivalent to many feet of the plain conduit, and often constitute the most important cause of pressure drop in technical operations. The theoretical treatment of such effects is a difficult matter, although certain rough empirical generations can be deduced from experience.

A good opportunity of testing the validity of a general formula, such as that of Stanton and Pannell, is afforded by application to the little investigated question of the loss of head in the flow of high-pressure gases through tubes; in the experience of the author, this formula gives valuable indications of the resistance under these conditions.

**Influence of Difference in Level.**—When making allowances for the drop in pressure due to dynamic effects, due consideration should be given to the static head if any considerable difference in level occurs, especially with very light or heavy gases.

Consider a pipe, open at one end and filled with a gas of

density  $\rho_1$ , while that of the surrounding medium, *e.g.* air, is  $\rho_2$ .

Then, in absolute units, the pressure difference due to the difference in weight of the gases—

$$= \pm hg (\rho_1 - \rho_2) \text{ dynes,}$$

where  $h$  = the vertical difference in height in cms.,

and  $g$  = the gravitational constant in C.G.S. units,

$$= \pm h (\rho_1 - \rho_2) \text{ grams.}$$

Expressing  $h$  in ft., and  $\rho_1, \rho_2$  in lbs./ft.<sup>3</sup>, and taking the case of a difference in level equal to 100 ft., with hydrogen in the pipe, at 15° C., we have—

$$\begin{aligned} \text{pressure difference} &= \frac{-100(5.32 - 76.49)}{1000} \text{ lbs./ft.}^2 \\ &= 7.117 \text{ lbs./ft.}^2 \\ &= 0.494 \text{ lbs./in.}^2 \\ &= 13.7 \text{ inches of water.} \end{aligned}$$

### Physical Methods of Testing the Purity of Gases.—

In special cases it is advisable to be able to determine the quantity of some specific impurity present in a particular gas, by physical means, either from reasons of speed or for purposes of automatic recording. Among such methods may be mentioned the following:—

*Gas Interferometer.*—This instrument was worked out by Haber and Löwe (*Z. angew. Chem.*, (1910), 1393). Its action depends on the formation of interference fringes by two columns of gases, one containing the impurity to be determined, *e.g.* carbon dioxide in air, and the other free from this impurity. The apparatus can be made extremely sensitive but is somewhat cumbersome and does not lend itself readily to the production of mechanical records. For technical adaptations, cf. "U.S. Bureau of Mines," Tech. Paper, No. 185 (1918), by Siebert and Harpster.

*Density.*—The density of a gas is often a good guide to its purity, particularly in the case of hydrogen, and a convenient apparatus for indicating the same is the "gas balance," which consists of a balance beam, one arm of which

carries a ball supplied with a continuous current of gas by means of mercury cups near the fulcrum of the beam, while the other carries a pointer. The balance is brought into equilibrium by means of riders.

*Effusion.*—The purity of a gas, *e.g.* the percentage purity of hydrogen containing small quantities of nitrogen, oxygen, carbon monoxide, etc., may also be ascertained by the rate of effusion through a fixed small aperture. For this purpose an inverted glass cylinder, immersed in a cylinder containing water, or a small water-sealed metal gasholder provided with a balance weight (this form being made by Messrs. Wright & Co.), is filled to a fixed mark with the gas in question, and the time required for the gas to flow out through a fine orifice in a piece of platinum foil, *i.e.* the time for the cylinder or bell to fall to another fixed mark, is noted. A comparison with a standard gas, *e.g.* air, or preferably a sample of the pure gas, say hydrogen, if this be the gas under examination, gives the density on the basis—

$$\rho \propto t^2$$

where  $\rho$  = the density of the gas,

$t$  = the time of outflow.

Determinations with this apparatus occupy only a few minutes; the results, of course, are not of a high degree of accuracy.

*Acoustical Methods.*—A method was worked out by Haber and Leiser (*J. Soc. Chem. Ind.*, (1914), 54) for the detection of methane in mine gases, depending on the difference in sound produced by two whistle tubes filled with pure air and mine air respectively, but separated by means of thin mica plates from the actual whistles, both of which are operated by the mine air.

**Separation of Gaseous Mixtures.**—Special cases of separation will be dealt with in particular instances, *e.g.* the separation of air into its various constituents, but a short forecast here of the possible methods will be useful. It is interesting to note that a certain irreducible amount of work must be expended on a gaseous mixture to separate

it into its components, equal to the work of isothermal compression of each constituent from its original partial pressure to atmospheric pressure or whatever the final pressure may be; cf. p. 80.

Among the various methods of separation, the following are the most important :—

- (1) Chemical methods.
- (2) By liquefaction of one of the constituents.
- (3) By fractional solution in water or other medium.
- (4) By fractional diffusion through platinum or porous earthenware, etc.
- (5) By centrifugal action.

It may be noted that (1) and (2), and in some cases (3), are the only methods which have any technical importance.

### **Separation of Liquid or Solid Particles from Gases.**

—In the technical manipulation of gases it is frequently necessary to free a gas from some suspended liquid or solid impurity, *e.g.* in the manufacture of coal gas, the separation of the “tar fog” is a matter of considerable difficulty, while in the concentration of sulphuric acid in Gaillard towers, the exit gases are liable to contain sulphuric acid in suspension. Without entering into details it will be useful to indicate the methods used in practice for the elimination of liquid or solid particles from gases.

This object may be achieved by direct filtration through sawdust, or by wetted gauze. A method frequently adopted for the separation of suspended matter present in considerable quantity, *e.g.* in the manufacture of white arsenic, is to subject the gases to centrifugal force by causing them to traverse a circular path or by means of a special fan; this throws out the bulk of the dust, the centrifugal separation being usually followed by bag filtration. The centrifugal separation in the fan is sometimes assisted by the injection of water.

Other methods depend on the use of gas velocities sufficiently low to allow precipitation of heavy dusts to occur, while considerable success has attended the use of abrupt changes in direction by means of baffles, the action being parallel to that occurring with centrifugalization.

In the case of "tar fog" and the like, passage through a number of small orifices or slits, followed by scrubbing with liquids, is often adopted.

Another mode of attack is to precipitate the dust by the formation of a mist on producing a condition of supersaturation in the gas, *e.g.* in the removal of dust from the gases leaving mechanical pyrites burners by addition of steam and sulphur trioxide, the resulting mist being subsequently removed by electrostatic precipitation or by other means (Möller, D.R.P. 270757/12).\*

The most searching method, however, is that depending on electrostatic action, rendered practical by Cottrell, and at the present time attracting considerable attention. On passing a dust-laden gas in proximity to two highly charged electrodes, the gas is ionized and the particles becoming charged move in the direction of the electrode of opposite charge. If one electrode is pointed the particles tend to become charged with the polarity of this electrode and, consequently, to move to the other electrode.

The usual method of operating is to pass the gases with linear velocity not exceeding about 12 ft./sec. through metal tubes of, say, about 1 ft. in diameter, enclosing axially disposed wires, a unidirectional potential difference of from 25,000 to 250,000 volts being applied. The dust is deposited on the tubes and periodically dislodged by interrupting the gas current and the electrical supply and by jarring the tubes.

The process is largely used in the removal of dust from the gases leaving pyrites burners; for the precipitation of cement dust, which contains valuable quantities of potash; for the precipitation of white arsenic, avoiding the handling necessary in "bag-houses"; in treating the effluents of Gaillard towers, etc. Some trouble is experienced in the presence of solids and liquids in conjunction. The unidirectional current is best obtained by means of a rotating commutator, operated in synchronism with a high tension

\* An ingenious proposal is made by Mond in B.P. 112153/16, to effect the removal of constituents from gaseous mixtures by first injecting a suspension of some solid which combines with or absorbs the constituent in question and subsequently separating the dust by suitable means.

transformer; the power consumption is of the order of from 1-8 K.W.H. per million ft.<sup>3</sup> of gas treated (cf. Bush, *J. Soc. Chem. Ind.*, (1918), 389R). The process is applicable to gases at fairly high temperatures; it is important to avoid conditions leading to the condensation of moisture.

**Methods of Measuring Volumes and Rates of Flow of Gases.**—One of the most convenient methods of measuring the volumes or rates of flow of gases through a given conduit, when the quantities are not too large, is that depending on the use of the familiar rotary (wet) meter or the reciprocating (dry) meter. The former consists of a series of inverted buckets, mounted on a wheel with a horizontal spindle, and immersed in a tank of water, the wheel revolving at a rate proportional to the volume of gas entering the buckets. Such meters are constructed in sizes up to about 150,000 ft.<sup>3</sup>/hr. They are very sensitive to the level of the water and calibration at frequent intervals is important when using for accurate laboratory work. If accuracy be required, it is necessary to allow for the volume of water vapour present, the effect of saturating the gas with water vapour at 15° C. being to increase the volume by 1.7%. Rotary meters of the anemometer type are convenient when dealing with large gas flows, especially as very little pressure drop is introduced. Meters capable of measuring the volume of the gas at pressures greater than atmospheric, *e.g.* "high-pressure" coal gas, natural gas, etc., are also constructed.

In many technical operations, however, one has to deal with very large currents of gases, *e.g.* in chimneys, or it may be desirable to measure or to record continuously the rate of flow in a given conduit of large diameter; in such cases it is necessary to make use of some kind of flow-meter. The measurement for relatively small conduits may be effected by the use of an "orifice meter," which consists of a perforated diaphragm introduced into the conduit and depends on observation, usually by means of a U-tube containing a suitable liquid, of the pressure drop caused by the constriction. The pressure drop varies roughly as the square of the gas flow and is rather sensitive to temperature

variations. The Venturi meter employs, instead of a simple orifice, a stream-line constriction. The increase in velocity gives rise to a fall in pressure *in* the constriction, but to only a very slight difference *across* the same; the fall in pressure varies roughly as the square of the gas flow.

When the size of the conduit becomes great, say more than 1 ft. in diameter, the use of an orifice meter is inconvenient, especially as it introduces into the system a pressure drop which may involve the expenditure of considerable amounts of energy. In such cases it is possible to employ an anemometer, *i.e.* a series of vanes with a train of recording dials, or to measure the "drag" on a bucket or plate suspended in the path of the stream, or, more commonly, use is made of a Pitôt tube, of which the indications are more easily converted into velocity figures; if made of glass, it is unaffected by corrosive gases or vapours.

This apparatus consists of tubes arranged as in Fig. 4 (cf. Pannell, *Engineering*, (1919), 261). The side openings (3 rows of 7 holes 0.04" diameter) are under the static pressure existing in the conduit, while the central tube has, in addition, the dynamic head due to the local arrestment of the current; consequently, by connecting the ends A and B to a suitable manometer, a pressure difference is registered which is connected with the linear velocity of the current as follows:—

$$v = \sqrt{2gh}$$

where  $v$  = the linear velocity at the point of the Pitôt tube, in cm./sec.,

$g = 981$  cm./sec.<sup>2</sup> (the gravitational constant),

$h$  = the height of the gas column equivalent to the head of liquid in the manometer.

If the indicating liquid be water and the moving gas be air, both at 15° C., the expression becomes—

$$\begin{aligned} v &= \sqrt{\frac{2 \times 981 \times 0.999h'}{0.001226}} \text{ cm./sec.} \\ &= 1264.5\sqrt{h'} \text{ cm./sec.} \end{aligned}$$

where  $h'$  is the head of water in cm.



Converting into the more practical units of ft./sec. and inches of water, we have—

$$v = \frac{1264.5\sqrt{h''} \times 2.54}{12 \times 2.54} \text{ ft./sec.}$$

$$= 66.1\sqrt{h''} \text{ ft./sec.}$$

where  $v$  = the linear velocity in ft.-sec.

$h''$  = the head of water in inches.

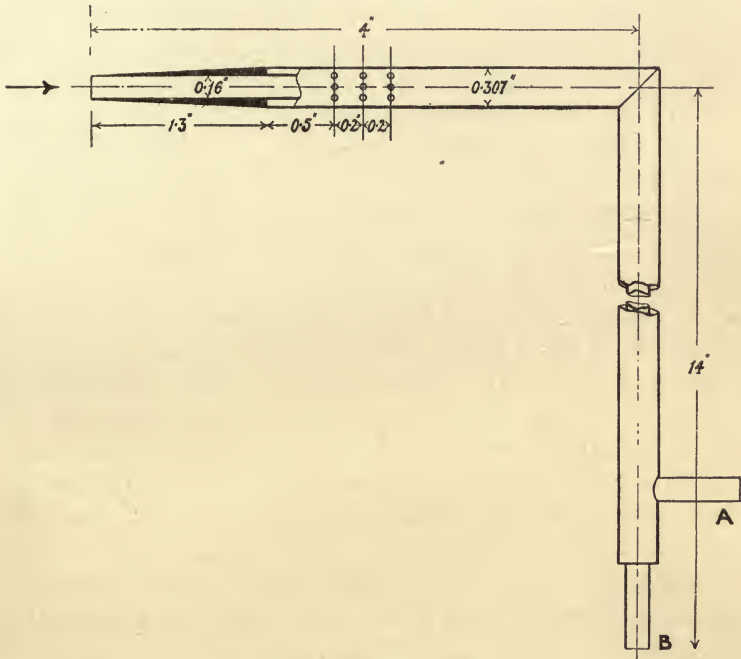

FIG. 4.—Pitôt Tube.

Thus, a linear velocity of 20 ft./sec. of air at 15° C. would give a head of water equal to—

$$\left(\frac{20}{66.1}\right)^2 \text{ in.} = 0.092 \text{ in.}$$

It is easy to see how corrections for density, temperature and pressure of the gas, or for density of the indicating liquid must be applied. In any case the readings do not give the mean linear velocity in the conduit as the velocity

varies from point to point, being greatest at the centre and zero at the walls. With stream-line motion the mean linear velocity is about 0.5 that of the axial velocity; at the critical velocity the ratio increases sharply to a value in the neighbourhood of 0.8 (cf. Stanton and Pannell, *loc. cit.*).

The Pitôt tube has many disadvantages; it involves the use of a delicate manometer, *i.e.* a tilting gauge in which a differential brine (S.G., 1.06) and castor-oil combination is often used instead of water for the measurement of the very small pressure difference (cf. Stanton, *Proc. Inst. Civil Eng.*, CLVI., (1904), 78), the readings being unsuitable for observation by a workman.

Recently, considerable attention has been directed, therefore, to the question of "hot-wire anemometry." A general description by Thomas of the relative advantages of this system of measurement will be found in *J. Soc. Chem. Ind.*, (1918), 165T. A thin wire, preferably of platinum, about 0.003 in. in diameter, is mounted either in the centre or at some other point in the conduit at which the relation of the actual to the average linear velocity is known. The wire, heated electrically, preferably to about 200° C., forms one arm of a Wheatstone bridge and the temperature fall produced by the gas current may be determined by measurement of the resistance which, of course, decreases with fall in temperature.

Calibration may be effected by checking against measurements obtained by other means or by calculation (cf. Morris, *Engineering*, (1912), 892). The expression for the heating energy ( $\omega$ ) for a particular temperature is  $C\omega = \sqrt{v + k}$ , where  $v$  = linear velocity and  $C$  and  $k$  are constants. Small changes in the pressure or temperature of the gas have no appreciable influence on the results if these be expressed in terms of mass of gas, not of actual linear velocity. The measurements are easily taken by a workman and can be recorded automatically, if desired.

Since the indications of the apparatus are considerably affected by turbulence of the gas under examination, it is desirable that the hot wire should be removed from proximity

to any bends or valves which often introduce or modify existing turbulence in a marked degree.

When gases which are decomposed by even gentle heating in contact with a heated metal surface, *e.g.* coal gas, are to be dealt with, the platinum wire may be coated with glass which, although it introduces a lag, does not affect the validity of the relation between the resistance of the wire and the gas velocity. By using two wires disposed transversely in the stream, one close behind the other, the direction of motion can be followed, as the downstream wire is partly shielded from cooling by being swept by the heated gas leaving the other.

**Automatic Safety and Purity Tests.**—In the routine control of technical gas reactions or treatments it is often desirable to make automatic tests—preferably capable of giving continuous records—of the percentage of specific impurities at different points of the plant. A familiar example of a recording gas analysis apparatus is the carbon dioxide recorder, which is chiefly used as a check on the combustion in boilers and the like. The most usual form, *e.g.* the Sarco apparatus, depends on the automatic measurement by the position of a small balanced gasholder, of a sample of gas before and after exposure to caustic soda solution. A filter pump or a stream of water is used to provide the necessary power for sucking in and ejecting the gases; the result of each analysis is registered by a pen attached to the little gasholder on a drum rotated by clockwork, the intervals between successive analyses being about five minutes.

In another form, a bi-meter recorder, made by the Cambridge Scientific Instrument Co., a continuous stream of gas is passed through two gas meters, between which is interposed a lime or soda-lime absorber. The difference in the readings gives the percentage of carbon dioxide. On similar lines is the form of apparatus in which two orifice gauges are used with soda-lime interposed (*J. Gasbeleucht.*, 1914, 548). Other methods operate through the measurement of the heat of absorption of carbon dioxide by alkalis.

For the automatic detection or determination of either oxygen or combustible gases in admixture with each other, *e.g.* the oxygen content of electrolytic hydrogen or the presence of methane in mine air, methods have been proposed, depending on the measurement of the rise in temperature produced by catalytic combination in the presence of platinum black or the like at the ordinary temperature, by means of air thermometers or by the change in resistance of wires coated with a catalyst (*cf.* Lunge's "Gas Analysis," 1914). Either method can be adapted to giving an alarm automatically or to furnishing a continuous record. These methods have some disadvantages, to overcome which an apparatus has been devised by Greenwood and Zealley (*J. Soc. Chem. Ind.*, (1919), 87 T), depending on the automatic measurement of the contraction resulting from the intermittent heating of a platinum wire in the gas mixture.

Only a few examples have been given above, but they are typical and will serve to indicate the general mode of attack in special cases.

**The Compression of Gases.**—This is a very important consideration, since most of the gases prepared technically are put on the market compressed to 120 atmospheres.

*Work of compression.*—It will be well to consider the principles determining the expenditure of energy required to effect the compression of gases as this energy constitutes an important item in the cost of the marketable gas.

In the first place it may be stated that in technical practice the compression approximates rather to adiabatic than to isothermal compression although efforts are made to minimize the increase in power involved thereby by adding water, the vaporization of which reduces the temperature rise, and by effecting the compression in a number of stages, which, as explained later, operates in the same direction.

*Adiabatic compression.*—Consider a volume of gas  $v_1$  at a pressure  $p_1$  when the temperature (absolute) is  $T_1$ .

Assume this gas to be compressed in an adiathermic

cylinder to a pressure of  $p_2$ , the volume falling to  $v_2$  and the temperature rising to  $T_2$ .

Now in this process the product  $p v_\gamma$  will remain constant, where

$$\gamma = \frac{C_p}{C_v}$$

equals the ratio of the specific heats at constant pressure and constant volume respectively, or

$$p = \frac{C}{v^\gamma}$$

where  $C$  is a constant.

The work of this adiabatic compression ( $W_1$ ) equals—

$$\int_{v_2}^{v_1} p \cdot dv = C \int_{v_2}^{v_1} \frac{1}{v^\gamma} \cdot dv = \frac{C}{1-\gamma} (v_1^{1-\gamma} - v_2^{1-\gamma})$$

Substituting  $C = p_1 v_1^\gamma = p_2 v_2^\gamma$  we have—

$$\begin{aligned} W_1 &= \frac{1}{1-\gamma} \left\{ p_1 v_1^\gamma (v_1^{1-\gamma}) - p_2 v_2^\gamma (v_2^{1-\gamma}) \right\} \\ &= \frac{1}{1-\gamma} (p_1 v_1 - p_2 v_2) \end{aligned}$$

But

$$\begin{aligned} \frac{p_1 v_1}{T_1} &= \frac{p_2 v_2}{T_2} \\ \therefore W_1 &= \frac{p_1 v_1}{T_1 (1-\gamma)} (T_1 - T_2) \\ &= \frac{p_1 v_1}{\gamma - 1} \cdot \left( \frac{T_2 - T_1}{T_1} \right) \end{aligned}$$

We have now compressed the gas to the required pressure, but its temperature is—

$$T_1 \left( \frac{p_2}{p_1} \right)^{\frac{\gamma-1}{\gamma}}$$

in accordance with the law for the effect of adiabatic compression from  $p_1$  to  $p_2$ .

In order to reduce its temperature to  $T_1$ , the initial temperature, we will consider the walls of the cylinder to become conducting. To prevent the pressure falling, it will be necessary to follow up the contracting gas with the

piston, a further amount of work ( $W_2$ ) being thus performed on the gas.

The volume after cooling to  $T_1$  will be—

$$v_1 \cdot \frac{p_1}{p_2}$$

assuming Boyle's Law to be valid.

Therefore, the volume before cooling, *i.e.* at  $T_2$ , will be—

$$v_1 \cdot \frac{p_1}{p_2} \cdot \frac{T_2}{T_1}$$

and the contraction—

$$= v_1 \cdot \frac{p_1}{p_2} \cdot \frac{T_2 - T_1}{T_1}$$

Since the pressure remains constant at  $p_2$ ,

$$\begin{aligned} W_2 &= v_1 \cdot \frac{p_1}{p_2} \cdot \left( \frac{T_2 - T_1}{T_1} \right) p_2 \\ &= \frac{p_1 v_1 (T_2 - T_1)}{T_1} \end{aligned}$$

Total work performed =  $W_1 + W_2$

$$\begin{aligned} &= \frac{p_1 v_1}{\gamma - 1} \cdot \frac{T_2 - T_1}{T_1} + p_1 v_1 \cdot \frac{T_2 - T_1}{T_1} \\ &= \frac{\gamma (p_1 v_1)}{\gamma - 1} \cdot \frac{T_2 - T_1}{T_1} \end{aligned}$$

Further— 
$$T_2 = T_1 \left( \frac{p_2}{p_1} \right)^{\frac{\gamma-1}{\gamma}}$$

Therefore 
$$W_1 + W_2 = \frac{\gamma (p_1 v_1)}{\gamma - 1} \left\{ \left( \frac{p_2}{p_1} \right)^{\frac{\gamma-1}{\gamma}} - 1 \right\}$$

For practical purposes it will be convenient to express  $p$  in atmospheres and  $v$  in ft.<sup>3</sup>, when the result will be in ft.<sup>3</sup> atms., 1 ft.<sup>3</sup> atm. \* representing the work done in moving a

\* 1 ft.<sup>3</sup> atm. =  $28.317 \times 10^3 \times 1.0132 \times 10^6$  ergs  
=  $2.8690 \times 10^{10}$  ergs.

1 K.W.H. =  $3.6 \times 10^8$  watt seconds  
=  $3.6 \times 10^6 \times 10^7$  ergs  
=  $3.6 \times 10^{13}$  ergs.

∴ 1 K.W.H. =  $\frac{3.6 \times 10^{13}}{2.8690 \times 10^{10}}$  ft.<sup>3</sup> atms.  
= 1255 ft.<sup>3</sup> atms.

or 1 H.P.H. =  $1255 \times 0.746$  ft.<sup>3</sup> atms. = 936 ft.<sup>3</sup> atms.

piston 1 ft.<sup>2</sup> in area through 1 ft. against a pressure difference of 1 atm. For further simplification, take  $p_1 = 1$  atm., and  $v_1 = 1000$  ft.<sup>3</sup>. Then—

$$W_1 + W_2 = \frac{1000\gamma}{\gamma - 1} \left\{ \left( \frac{p_2}{p_1} \right)^{\frac{\gamma-1}{\gamma}} - 1 \right\} \text{ft.}^3 \text{atms.}$$

and for diatomic gases—

$$\begin{aligned} W_1 + W_2 &= \frac{1000 \times 1.41}{0.41} \left\{ \left( \frac{p_2}{p_1} \right)^{0.29} - 1 \right\} \text{ft.}^3 \text{atms.} \\ &= \frac{1000 \times 1.41}{0.41 \times 936} \left\{ \left( \frac{p_2}{p_1} \right)^{0.29} - 1 \right\} \text{H.P.H.} \\ &= 3.674 \left\{ \left( \frac{p_2}{p_1} \right)^{0.29} - 1 \right\} \text{H.P.H.} \end{aligned}$$

As an example, let us take the compression of 1000 ft.<sup>3</sup> of air from 1 atm. to 201 atms., starting and finishing the operation at the same temperature, *e.g.* 15° C.

Work then equals—

$$3.674 \left\{ \left( \frac{201}{1} \right)^{0.29} - 1 \right\} \text{H.P.H.} = 13.4 \text{H.P.H.}$$

It is interesting to see the effect on the efficiency of compressing in a number of stages, *e.g.* consider the operation to be effected in three stages, the pressure in each phase rising to 201<sup>1/3</sup> times (5.86 times) the starting pressure with intermediate cooling to the initial temperature. Thus,

In the first stage the pressure rises from 1 to 5.86 atms.

second ,, ,, ,, 5.86 ,, 34.3 ,,

third ,, ,, ,, ,, 34.3 ,, 201.0 ,,

It is obvious that the temperature rise in each stage will be—

$$\begin{aligned} T_2 - T_1 &= T_1 \left( \frac{5.86}{1} \right)^{0.29} - T_1 \\ &= T_1 \left( \frac{201}{1} \right)^{\frac{0.29}{3}} - T_1 \end{aligned}$$

Consequently the work done in each case will be the same and equal to—

$$3.674 (5.86^{0.29} - 1) \text{H.P.H.} = 2.462 \text{H.P.H.}$$

while the total work of compression will be—

$$3 \times 2.462 \text{ H.P.H.} = 7.386 \text{ H.P.H.}$$

The general form of the expression for multi-stage compression, where  $n$  = the number of stages, is—

$$W = \frac{\gamma n (p_1 v_1)}{\gamma - 1} \cdot \left\{ \left( \frac{p_2}{p_1} \right)^{\frac{\gamma-1}{\gamma n}} - 1 \right\} \text{ H.P.H.}$$

or, per 1000 ft.<sup>3</sup> of a diatomic gas measured at 1 atm. pressure—

$$W = 3.674n \left\{ \left( \frac{p_2}{p_1} \right)^{0.29n} - 1 \right\} \text{ H.P.H.}$$

*Isothermal compression.*—Consider a volume of gas  $v_1$  at pressure  $p_1$  to be compressed to  $p_2$ . If the compression be performed in such a way that the heat produced escapes so rapidly that no increase in temperature occurs, the work performed is given by the expression—

$$\begin{aligned} W &= \int_{v_2}^{v_1} p \cdot dv \\ &= p_1 v_1 \int_{v_2}^{v_1} \frac{1}{v} \cdot dv \\ &= p_1 v_1 \log_e \frac{v_1}{v_2} \\ &= p_1 v_1 \log_e \frac{p_2}{p_1} \end{aligned}$$

assuming Boyle's Law throughout.

In this case the number of stages has no influence, and taking again the case of 1000 ft.<sup>3</sup> of gas at 1 atm. pressure to be raised to 201 atms.—

$$\begin{aligned} W &= 1000 \log_e 201 \text{ ft.}^3 \text{ atms.} \\ &= 5300 \text{ ft.}^3 \text{ atms.} \\ &= \frac{5300}{9.36} \text{ H.P.H.} = 5.66 \text{ H.P.H.} \end{aligned}$$

In actual practice, with large multi-stage (3—5) compressors, the overall efficiency allowing for friction losses, etc., is some 80 % of that calculated as above for adiabatic compression.



Thus, with three-stage compression, the power for the compression of 1000 ft.<sup>3</sup> of air to 200 atmospheres would be—

$$\frac{7.386}{0.8} \text{ B.H.P.H.} = 9.233 \text{ B.H.P.H.}$$

equivalent to 6.89 K.W.H.

Allowing for an efficiency of, say, 85 % in the electric motor driving the compressor, the actual energy expenditure would be 8.11 K.W.H.

The power demanded in practice is found to vary from about 12 to 8 K.W.H. per 1000 ft.<sup>3</sup>, according to the size of the plant.

**Notes on Compressed Gases—Safety Precautions.**—In dealing with compressed gases, due regard should be paid to the question of the strength of materials and to the correct engineering design of the containers and conduits employed. In fact, an elementary knowledge of the methods of calculating the factors of safety of the various parts of the apparatus used, of the mechanical properties of the steels and other materials used in the construction of high-pressure plant, and of the influence of mechanical work and heat treatment on the same may be said to be a *sine qua non*. The material for the construction of the weldless steel cylinders employed for the commercial transport of compressed gases is legally defined in this country as steel containing not more than 0.25 % carbon. For further details, mechanical tests, etc., cf. Recommendations of the Parliamentary Committee on the Manufacture of Compressed Gas Cylinders, 1895.

When dealing with inflammable gases, it is very important to make sure by analysis that oxygen is absent from the gases undergoing compression, or at any rate is present only in small quantities well below the limit of inflammability, since the momentary temperature rise on the compression stroke is often sufficient to cause explosion; similarly, it is important that the compressor should be specially designed for use with inflammable gases, *i.e.* it should be

of the enclosed type—not open, as in the ordinary Whitehead “liquid air” compressor, for example.

The limits between which explosion is possible are given below for a number of gases. The values are for atmospheric pressure.

TABLE 5.  
EXPLOSIVE LIMITS.

Gas.	Minimum % air in gas for explosion.	Minimum % gas in air for explosion.
Hydrogen .. .. .	25·8*	4·1*
Carbon monoxide .. .. .	25·8*	12·5*
Methane .. .. .	84·6*	5·3*
Coal gas .. .. .	79†	7†
Blast furnace gas .. .. .	35†	36†
Water gas (Bunte, 1901) .. .. .	33·25	12·4

With electrolytic gas which may contain oxygen undiluted by nitrogen the limits are considerably smaller (cf. p. 202). Increased pressure appears to have no noteworthy effect on the limits of inflammability (cf. Burrell and Gauger, *loc. cit.*). Further investigations carried out by Burrell and Robertson (*Technical Paper*, No. 121) with methane show that reduction of pressure has the effect of narrowing the explosive limits; thus, no methane-air mixture will ignite at pressures below 275 mm. On the other hand, the same investigators found that in the case of methane the limits were widened by increase of temperature; the minimum percentage of methane in air for inflammation is lowered from 5·5% at the ordinary temperature to 3·75–4% at 500° C.

According to Terres and Plenz (*J. Gasbeleucht.*, 57, (1914), 990, 1001, 1016), in the case of mixtures of hydrogen, carbon monoxide and methane with air, the effect of increased pressure is to narrow the explosive limits, especially for carbon monoxide mixtures, the upper limit of methane being an exception. Increase of temperature widens the limits.

\* Coward, *Chem. Soc. Trans.*, (1914), 1859; Coward, Carpenter and Payman, *Ib.*, (1919), 27.

† Burrell and Gauger, *Technical Paper*, No. 150, Bureau of Mines, U.S.A.

*A propos* of the danger of explosion from the possibility of meeting with explosive mixtures in cylinders the following precautions are desirable in the manipulation of compressed gases :—

(1) The avoidance of sudden opening of valves leading to gauges, etc. By the adiabatic compression of the first portion of gas, sudden opening of a valve may raise the temperature to the ignition point and a similar effect may be produced by friction in closing a valve, or by the presence of finely divided iron, etc.

(2) Consistent analysis of the contents of cylinders before exposing to conditions which might initiate an explosion while still under high pressure, also if the contents of several cylinders are to be mixed under high pressure.

When compression of an inflammable gas is performed the compressed gas should be tested for the presence of any oxygen which may have been introduced accidentally during the compression.

In order to avoid any confusion and to guard against the possibility of such disastrous mistakes as the filling up with oxygen of a cylinder partly filled with an inflammable gas, or vice versa, rigid rules are observed by all filling works that each cylinder shall be emptied before recharging and that all cylinders containing inflammable gases shall be fitted with left-handed screw connections; oxygen, air, nitrogen, etc., are carried in cylinders with right-handed connections. Further, the cylinders are painted distinctive colours: thus, hydrogen is contained in red cylinders, oxygen in black, and nitrogen or air in grey cylinders. To guard against the possibility of deposits from coal gas and the like, cylinders which have been fitted with left-handed valves are always annealed before being fitted with right-handed valves. All cylinders, of course, are annealed and re-tested at regular intervals.

For a discussion of the results of carelessness in respect of the above-mentioned precautions, cf. Wöhler, *Z. angew. Chem.*, **30**, (1917), 174. Manometers and the like should

be provided with gas checks, *i.e.* constrictions to minimize the effect of sudden admission of gas.

(3) The insertion of explosion traps, *e.g.* tubes packed with copper gauze or steel wool, may often be advisable in cases where explosion is possible.

Oxygen is a dangerous gas to compress unless proper precautions are taken, while manipulation of the compressed gas requires care, as in the presence of oil, etc., an explosion is easily initiated in various ways, as indicated above. All oxygen pressure gauges and connections should be scrupulously free from oil or other organic matter, and only water can be used for the lubrication of the compressors (cf. Rasch, *Z. für komp. u. flüssige Gase*, (1904), 141). Acetylene, being an endothermic compound, is very dangerous to compress by reason of its liability to detonate.

It has been observed in the rapid release of compressed hydrogen that ignition occasionally occurs. The origin of the phenomenon is somewhat uncertain; possible sources are electrical sparks due to dust disturbed from the valve, etc., or the catalytic or pyrophoric action of finely divided iron oxide or metal present in the cylinder or valve passages.

A feature of compressed gases which should be borne in mind is the almost complete dryness of a gas at, say, 100 atmospheres pressure. Thus, at 15° C. the percentage of water vapour will be about—

$$\frac{12.8 \times 100}{760 \times 100} \text{ per cent.} = 0.017 \text{ per cent.}$$

as compared with a possible 100 times this amount at the ordinary pressure.

Cylinders of compressed gas should be kept in a cool place as a rise in temperature of, say, 20° C. would raise the pressure from the normal value of 120 atms. to some 128 atms.

*Liquefied gases.*—Reference has been made to the necessity of keeping cylinders of compressed gases cool; much more does this consideration apply to cylinders containing liquefied gases, especially if the cylinders have been somewhat overcharged with liquid. The following table, adapted from

Teichmann, *Komprimierte und verflüssigte Gase*, 1908, shows the way in which the sensitivity to warming varies with the degree of filling.

The figures are based on Regnault's vapour-pressure measurements (cf. Table 7). The "normal fillings" are those given in the third column and are according to German regulations.

TABLE 6.

RELATION BETWEEN DEGREE OF FILLING AND PRESSURE IN CYLINDERS CONTAINING LIQUEFIED GASES.

Gas.	Volume of 1 kilo. of liquid at 15° C.	Minimum cylinder space per kilo. of liquid (litres).	Absolute pressure (atms.) exerted at temperatures given (°C.).														
			Normal filling.					5 % over-filling.					10 % over-filling.				
			0	10	20	30	40	0	10	20	30	40	0	10	20	30	40
Sulphur dioxide	0·716	0·8	1·53	2·26	3·24	4·52	6·15	1·53	2·26	3·24	4·52	6·15	1·53	2·26	3·24	13 at 23·9° C.	—
Carbon dioxide	1·230	1·34	35·4	46·0	58·8	98·5	138	34·4	46·0	66·4	110	151	35·4	46·0	76·6	120	162
Nitrous oxide	1·205	1·34	36·1	44·8	55·4	79·8	126	36·1	44·8	55·4	99·5	152	36·1	44·8	68·1	120	177

The rises in pressure are greater than the vapour pressures of the respective liquids at the temperatures in question, as is seen from the following table:—

TABLE 7.

VAPOUR PRESSURES OF LIQUEFIED GASES.

Gas.	Absolute vapour pressure (atms.) at temperature given.					
	0° C.	10° C.	20° C.	30° C.	40° C.	
Sulphur dioxide	1·52	2·26	3·24	4·52	6·15	Regnault, 1862.
	1·51	2·35	3·30	4·60	6·20	
Carbon dioxide	35·4	46·0	58·8	73·8	91·0	Regnault, 1862.
	34·3	44·2	56·3	70·7	—	Amagat, 1892.
Nitrous oxide . .	36·1	44·8	55·3	68·0	83·4	Regnault, 1862.
	30·8	—	49·4	—	—	Villard, 1897.

Note.—At 40° C. both carbon dioxide and nitrous oxide are above their critical temperatures. The difference is due to the bottle becoming filled with liquid, of course, and

the temperature at which this would occur at the above cited degrees of filling is given in the following table (Teichmann, *loc. cit.*) :—

TABLE 8.

Gas.	Temperature (°C.) at which completely full with		
	normal filling, <i>i.e.</i> as in column 3, Table 6.	5 per cent. over-filling.	10 per cent. over-filling.
Sulphur dioxide .. .. .	64·6	45·3	23·2
Carbon dioxide .. .. .	21·2	18·1	14·2
Nitrous oxide .. .. .	24·9	20·5	16·1

In the case of carbon dioxide, the question is discussed very fully by Stewart (*Trans. Amer. Soc. Mech. Eng.*, **30**, (1908), IIII), according to whom the temperature at which the cylinder becomes completely filled with liquid is connected with the amount of the charge as follows :—

TABLE 9.

Cylinder volume in litres per kilo. carbon dioxide .. .. .	1·8	1·6	1·4	1·2
Temperature at which the cylinder becomes full. °C. .. .. .	30-31	28-30	26	15-20

An allowance of about 1·6 litres/kilo. carbon dioxide (or 39 lbs./ft.<sup>3</sup>) is recommended by Stewart as a result of his calculations and experiments.

As the cylinder becomes full of liquid the pressure rise becomes much steeper, although the rate of increase is of a different order from that obtaining with water, for example. When the liquid gas is very near its critical temperature, *e.g.* carbon dioxide,  $T_c = 31·1^\circ \text{C.}$ , the coefficient of expansion becomes relatively very large, but the compressibility also increases, causing the pressure curve to be less steep than might have been expected.

In this country the recommendation of the Parliamentary Committee on the Manufacture of Compressed Gas Cylinders,

1895, is that the charge of carbon dioxide shall not exceed 0.75 lb. per lb. of water capacity, while a figure of  $\frac{3}{8}$  lb. is given for tropical use, corresponding to 46.9 and 41.7 lbs./ft.<sup>3</sup> respectively ; for ammonia, 0.5 lb. per lb. of water capacity is recommended as a maximum ; no specific recommendations are made for sulphur dioxide and nitrous oxide. The Committee recommends a test pressure of 224 atms. for the cylinders in the case of carbon dioxide ; attention is drawn to the regulations in force on the German railways, given below—

TABLE 10.

## GERMAN RAILWAY REGULATIONS FOR CYLINDERS OF LIQUEFIED GASES.

Gas.	Minimum cylinder volume per kilo. (litres).	Test pressure (atms.).
Carbon dioxide .. .. .	1.34	250
Nitrous oxide .. .. .	1.34	250
Ammonia .. .. .	1.86 *	100
Chlorine .. .. .	0.9	50
Sulphur dioxide .. .. .	0.8	30
Phosgene .. .. .	0.8	30

In the filling of cylinders with liquid gases the complete exclusion of air is important, since the presence of a permanent gas has a considerable effect on the pressure set up in the cylinder.

When sampling liquefied gases the sample is best taken with the cylinder in an inverted position, using a fine regulation valve ; either liquid or gas can thus be withdrawn without contamination with any air which may be present in the space above the liquid ; compare, however, remarks relating to nitrous oxide on pp. 289, 290.

**Heat-Interchange.**—The cost of nearly all technical operations depends on the fuel consumption which, in turn, is determined by the operations of heating or cooling to which the gases, or their parent substances or products, are subjected. In almost all cases the final temperature is the same as the initial temperature, *i.e.* that of the atmosphere, and therefore, apart from heat usefully employed in

\* 2.0 litres/kilo. recommended by British Committee.

effecting endothermic reactions, the heat is theoretically capable of regeneration.

It will therefore be well to examine now the factors which influence the transfer of heat between gases and gases (through a partition) or between gases and solids.

Suppose one to require a knowledge of the rate of transfer of heat per unit surface per degree C. temperature difference per unit of time over a very short length of tube, and also of the relation between this quantity and the linear velocity of a gas, initially at a temperature  $t_1$ , passing through a metal tube the outer surface of which is maintained at a lower temperature,  $t_2$ .

The rate of transfer does not depend, to any great extent, on the thermal conductivity of the metal tube as might at first be thought, the gas itself offering so much resistance to heat flow that the resistance of the metal is almost negligible in comparison. If the gas be flowing with stream-line motion, the rate of transfer will be very low indeed, since it can only occur by conduction from layer to layer of the gas, and gases are very poor conductors of heat.

When, however, the critical velocity is exceeded, we have an approach to temperature equilibration across the bore of the pipe; but, although very much better, the heat transference still falls far short of that which is possible, as far as the thermal conductivity of the walls is concerned. This is due to a stagnant film of gas on the walls of the conduit. The effect of increased linear velocity is to decrease mechanically the thickness of this film with consequent increase in the value of the heat transfer coefficient.

According to Porter (*Trans. Institution of Engineers and Shipbuilders in Scotland*, Nov. 19, 1918), following Osborne Reynolds, the coefficient of heat transfer from a given fluid to the walls of the tube through which it is flowing (or vice versa) for turbulent motion may be expressed in general terms as follows:—

$$K = MC \left( \frac{v\rho}{\mu} \right)^{n-1} d^{n-2}$$



where  $K$  = the coefficient of heat transfer,  
 $C$  = the thermal conductivity of the fluid,  
 $v$  = mean linear velocity of the fluid,  
 $\rho$  = density of the fluid,  
 $\mu$  = viscosity of the fluid,  
 $d$  = diameter of the tube,  
 $M$  = a constant,

all in absolute units.

Since a survey of experimental measurements indicates that  $n$  may be taken as about 1.75, the equation becomes—

$$K = MC \left( \frac{v\rho}{\mu} \right)^{\frac{1}{2}} d^{\frac{1}{2}}$$

The main inferences to be drawn from this relation are—

(1) The heat transfer coefficient will vary as the 0.75 power of the linear velocity.

(2) Except for stream-line motion, the thermal conductivity of the fluid is not of itself the determining factor as regards heat interchange; thus, although hydrogen has a high thermal conductivity as compared with air, its density is relatively small, while the viscosity is about half that of air. The relative values are seen to be in the ratio—

$$\frac{K_{H_2}}{K_{air}} = \frac{C_{H_2}}{C_{air}} \left( \frac{\rho_{H_2}}{\rho_{air}} \cdot \frac{\mu_{air}}{\mu_{H_2}} \right)^{0.75}$$

for turbulent motion, and equal values of  $v$  and  $d$ —

$$= \frac{41.65 \times 10^{-5}}{5.67 \times 10^{-5}} \left( \frac{0.000089873 \times 173 \times 10^{-6}}{0.0012928 \times 86 \times 10^{-6}} \right)^{0.75}$$

at 0° C.  $\qquad \qquad \qquad = 1.68$

(3) The coefficient of transmission will slowly fall off as the diameter of the tube increases, thus, an increase in diameter from 1 to 6 inches with otherwise unchanged conditions of linear velocity, etc., results in the decrease in the coefficient in the ratio of—

$$1 : \frac{1}{6^{0.25}} = \frac{1.565}{1}$$

In an investigation with water, Stanton (*Phil. Trans., A*, (1897), 67) found the index of the power of  $d$  to be 0.16).

(4) The coefficient will increase rapidly with increase in the pressure of the gas, since the density is approximately proportional to the pressure, while the viscosity and thermal conductivity\* are almost independent of pressure. Thus one would expect the coefficient for a pressure of 100 atms. to be some  $101^{\frac{1}{2}} = 32$  times that at atmospheric pressure for equal linear velocity.

Further, since in regard to pressure variations—

$$K \propto (v\rho)^{\frac{1}{2}} \propto (PV)^{\frac{1}{2}}$$

where  $P =$  pressure and  $V =$  volume, it is evident that  $K$  will be practically constant for all pressures, provided that  $v\rho$  or  $PV$  is constant, *i.e.* provided that the quantity of gas flowing through the conduit in unit time remains the same.

The above considerations apply equally to liquids; the values of the coefficient, however, are much higher, namely of the order of several hundred times those observed with gases at atmospheric pressure for equal linear velocity. It will be found convenient to express the coefficient  $K$  in terms of C.H.U./ft.<sup>2</sup>/hr./°C. temperature difference.

There are three principal types of heat transfer, as regards gases, to be considered—

(1) Heat passes from a gas to a solid, or vice versa. Here we need to consider the heat transfer coefficient for one gas film only.

(2) Heat passes from a gas through a thin metal partition to a liquid, or vice versa. In this case, let—

$k_g =$  the coefficient of transfer between gas and metal for the rate of flow obtaining,

$k_w =$  the coefficient of heat transfer between liquid and metal for the rate of flow obtaining.

Then

$$K = \frac{1}{\frac{1}{k_g} + \frac{1}{k_w}}$$

neglecting the effect of the tube itself.

\* The thermal conductivity of a gas may be expressed as  $1.603\mu C_p$ , and, since the viscosity and specific heats are not greatly affected by changes of pressure, the thermal conductivity may be taken as approximately constant.

A little consideration will show that it is almost correct to neglect  $k_w$  and to take the coefficient of the gas alone, this being the determining factor. An example of this type of interchange is the cooling of air by passing over cold brine pipes.

(3) Heat passes from one gas through a thin metal partition to another gas.

This is the state of affairs in the usual gas heat-interchanger, *e.g.* in the B.A.M.A.G. continuous catalytic process for the production of hydrogen (p. 161). In such a case the coefficient—

$$K = \frac{1}{\frac{1}{k_{g_1}} + \frac{1}{k_{g_2}}}$$

will be of the order of half the value of  $k_{g_1}$  or  $k_{g_2}$  if these are fairly similar, *i.e.* if similar conditions of motion and pressure obtain in both gas currents.

If, however, one gas be at a high pressure and the other at atmospheric pressure, as, for example, in a liquid air machine heat-interchanger, the conditions will resemble those in case (2), the low pressure gas determining the situation although the coefficient of heat exchange between the compressed gas at, say, 100 atmospheres pressure, and the metal is of the order of 30 times that obtaining in the case of the low pressure gas for similar conditions of motion.

*A propos* of the investigation of existing plant and the design of new, it is important to note that the mean temperature difference is not the mean of the initial and final temperature differences, except in the case of a heat-interchanger with counter-current flows of equal thermal capacities, when the temperature gradient is constant. The mean temperature gradient may be calculated for all cases as follows:—

$$t_{\text{mean}} = \frac{t_1 - t_2}{\log_e t_1/t_2}$$

where  $t_1$  = the temperature difference at one end of the heat transfer process,

$t_2$  = the temperature difference at the other end of the heat transfer process.

Some values due to Josse are given by Hausbrand ("Verdampfen, Kondensieren und Kühlen," Berlin, Fünfte Auflage, 1912) for air at a pressure of 1.034 atms. traversing a pipe 0.9 in. diameter, the outside of which was kept at 100° C. by steam. Since saturated steam gives a high coefficient of heat transfer, the values may be taken as applicable to a single air film. The values are adapted from a smoothed curve.

TABLE II.

HEAT-INTERCHANGE COEFFICIENTS FOR AIR (SINGLE FILM).

Mean linear velocity of air in ft./sec.	5	10	20	30	40	50	60
K. in C.H.U./ft. <sup>2</sup> /hr./° C. .. ..	1.6	2.9	5.1	6.8	8.5	9.9	11.2

The relation between K and the linear velocity is approximately that given on p. 47.

NOTE.—The calculated critical velocity for this case is about 5 ft./sec.

**Desiccation of Gases.**—It is often necessary to carry out the operation of desiccation on large quantities of gas. Thus, all the air which enters an air liquefaction plant must be scrupulously dried and similarly with the gases for the manufacture of hydrogen by the Linde-Frank-Caro process (cf. p. 172). In both cases, as will be described later, the desired effect is best secured by refrigeration.

A less obvious example of need for desiccation is that of the air supplied to blast furnaces, the reason lying in the endothermic nature of the reaction between water vapour and carbon. The water present in the air at 15° C., if, say, 75 % saturated (vapour pressure of water at 15° C. being 12.8 mm.)



order to avoid the energy demanded by the absorption of the latent heat of solidification. The vapour pressure at  $-5^{\circ}$  C. is about 3 mm., *i.e.* the percentage of water vapour left in the air,

$$= \frac{3 \times 100}{760} = 0.395 \% \text{ by volume.}$$

A heat-interchanger is used, of course, to minimize the power expenditure.

An alternative method is to pass the air up a tower, down which cooled, concentrated calcium chloride liquor is sprayed; the weakened liquor is re-concentrated, re-refrigerated and returned to the system (*cf. Chem. Trade J.*, **62**, (1918), 113). Besides that of diminished fuel consumption, the drying has further advantages, such as the decreased air blast required and diminution in the dust present in the exit gases; but the high cost of the cooling plant must be taken into consideration in computing the economics of air desiccation.

**The Storage of Gas.**—In most operations relating to gases, it is necessary to store considerable quantities of gas to serve as a balance against irregular operation of the gas-producing plant, or variable demand, as in the case of coal gas. In such cases it is usual to store the gas in holders consisting of a bell or a series of bells rising and falling in a water seal. Such gas holders have been constructed up to a capacity of about 17 million ft.<sup>3</sup>. It is, however, sometimes convenient to store gas at a pressure of about 20 atmospheres in cylindrical vessels of about 3 in. diameter, while similar vessels are used for railway transit.

**Reference Data.**—In the following tables will be found collected data which are useful in connection with technical gas problems. The data for the table of physical constants have been selected from the best modern determinations.

TABLE 12 (A).

Gas.	Formula.	Atomic (molecular) weight.	Weight of 1 litre at N.T.P. (grams).	Weight of 1000 ft. <sup>3</sup> at 15° C. and 1 atm. in lbs.	Volume of 1 lb. at 15° C. and 1 atm. (ft. <sup>3</sup> ).	Ft. <sup>3</sup> of gas in a vessel of 1 ft. <sup>3</sup> capacity at 120 atms. (121 absolute).
Air..	—	—	1'2928	76'49	13'074	122'6
Oxygen	O <sub>2</sub>	16'00	1'4290	84'56	11'827	128'3
Nitrogen	N <sub>2</sub>	14'01	1'2507	74'00	13'513	120'9
Argon	A	39'88	1'782	105'45	9'483	—
Neon	Ne	20'2	0'9002	53'28	18'771	—
Helium	He	4'00	0'1785	10'56	94'7	—
Xenon	Xe	130'2	5'837	345'4	2'895	—
Krypton	Kr.	82'92	3'707	219'4	4'558	—
Nitron	Nt	222'0	9'97	—	—	—
Ozone	O <sub>3</sub>	48'00	—	—	—	—
Hydrogen	H <sub>2</sub>	1'008	0'089873	5'319	188'01	111'8
Carbon monoxide..	CO	28'005	1'2504	73'99	13'515	121'7
Carbon dioxide	CO <sub>2</sub>	44'005	1'9768	116'88	8'556	—
Sulphur dioxide	SO <sub>2</sub>	64'06	2'9266	172'61	5'794	—
Nitrous oxide	N <sub>2</sub> O	44'02	1'9777	116'95	8'551	—
Methane ..	CH <sub>4</sub>	16'037	0'717	42'4	23'6	150

TABLE 12 (B).

Gas.	Specific heat at constant pressure at temperatures near atmospheric.		Specific heat at constant volume at temperatures near atmospheric. C.H.U./lb	Ratio of the specific heats at temperatures near atmospheric.	Critical temperature. °C.	Critical pressure, atms.	Boiling point. °C.	Melting point. °C.	Latent heat of vaporization (near the boiling point), C.H.U./lb.
	C.H.U./lb.	C.H.U. per 1000 ft. <sup>3</sup> at 15° C. and 1 atm.							
Air .. .. .	0'2417	18'5	0'1715	1'403	-140	39	{ 21 % O <sub>2</sub> -194 50 % O <sub>2</sub> -191 }	—	ca. 50
Oxygen .. .. .	0'218	18'4	{ 0°-2100° C. } 0'183	1'400	-118'0	49'30	-183	-218	51
Nitrogen .. .. .	0'2429	17'97	0'168	1'41	-144'7	33'65	-196	-210	50
Argon .. .. .	0'123	13'0	{ 0°-2000° C. } 0'0746	1'667	-122'6	47'996	-186	-188	—
Neon .. .. .	—	—	—	1'642	ca. -213	29	-239	-253(?)	—
Helium .. .. .	4'993	52'72	—	1'660	-268	2'75	-269	< -271	—
Xenon .. .. .	—	—	—	1'666	16'6	58'2	-109	-140	—
Krypton .. .. .	—	—	—	1'689	-62'5	54'3	-152	-169	—
Nitron .. .. .	—	—	—	—	377'5	62'5	—	—	—
Ozone .. .. .	—	—	—	1'29	-109	—	-119	—	—
Hydrogen.. .. .	3'422	18'20	0'2402	1'408	-241'2	11'0	-252	-259	123
Carbon monoxide .. .. .	0'242	17'9	—	1'401	-138'7	34'60	-190	-207	51'2
Carbon dioxide .. .. .	0'202	23'6	0'1508	1'300	31'1	73	-78'5	-65	32 at 22° C.
Sulphur dioxide .. .. .	0'154	26'6	—	1'26	155'4	78'9	-11'0	-76	96 at -10° C.
Nitrous oxide .. .. .	0'213	24'9	—	1'324	38'8	77'5	-88'7	-102	67 at -20° C.
Methane .. .. .	0'59	25'1	—	1'313	-82'85	45'60	-164	-184	—



TABLE 12 (c).

Gas.	Density of the liquid at the boiling point.	Solubility in water at 15° C. C.c. of gas at N.T.P. in 1 c.c. water at 1 atm. pressure, (A) including, (B) excluding water vapour.	Thermal conductivity at 0° C.	Refractive index sodium D line.	Joule-Thomson Effect $\frac{dP_1 - P_2}{dT}$ for atm. at 0° C. Pressures near atmospheric.	Viscosity at 15° C.	Temperature coefficient of viscosity	
							$\theta = \frac{\mu}{K\theta^2} - C.$	$\theta = \frac{\mu}{\text{abs. temperature.}}$
			$\times 10^{-5}$			$\times 10^{-6}$	C	K
Air..	0.875 for 21 % O <sub>2</sub>		5.67	1.0002918	0.277	181	124	150
Oxygen ..	1.14	0.02055 (A) 0.034 (B)	5.768	1.000272	0.326	195	127	175
Nitrogen ..	0.804	0.0179 (B)	5.660	1.000297	0.31	173	110	143
Argon ..	1.4046	0.040 (B)	3.850	1.0002837	—	221	170	207
Neon ..	—	0.0147 at 20° C. (B)	10.89	1.0000671	—	312	56	220
Helium ..	0.154	0.0138 (B)	34.38	1.0000350	—	197	80	148
Xenon ..	3.06	0.1109 at 20° C. (B)	—	1.000702	—	.222	252	246
Krypton ..	2.155	{ 0.0670 - 0.0788 } at 20° C. (B)	—	1.0004273	—	246	188	240
Nitron ..	ca. 5	—	—	—	—	—	—	—
Ozone ..	—	—	—	—	—	—	—	—
Hydrogen..	0.0700	0.0190 (B)	41.65	1.0001384	—	89	72	66
Carbon monoxide	0.793	0.025 (B)	4.99	1.000334	—	179	102	135
Carbon dioxide ..	1.191 at -60° C.	0.019 (B)	3.07	1.0004498	1.46	146	240	158
Sulphur dioxide ..	1.46	47.3 (A)	3.393	1.000660	—	134	—	—
Nitrous oxide ..	0.91 at 0° C.	0.74 (B)	3.530	1.000515	—	142	313	172
Methane ..	0.415	0.369 (B)	7.2	1.000441	—	116	—	—

TABLE 13.

	Heat of combustion. C.H.U. per 1000 ft. <sup>3</sup> at 15° C.		Heat of formation. C.H.U. per lb. mol.	Coefficient of expansion of the liquid.
	Net.	Gross.		
Ozone .. ..	—	—	$\times 10^3$ 68'0	—
Hydrogen ..	153,300	181,200	—	—
Carbon monoxide	180,500	—	{ 29 from amorphous C.	—
Carbon dioxide ..	—	—	{ 97'3 from amorphous C.	15° C. 0'01012 20° C. 0'01308
Sulphur dioxide ..	—	—	{ 70 from rhombic S.	15° C. 0'00186 20° C. 0'00192
Nitrous oxide ..	—	—	—19'5	15° C. 0'00852 20° C. 0'01112
Methane .. ..	506,000	562,000	{ 21'7 from amorphous C.	—

TABLE 14.

## USEFUL CONVERSION FACTORS.

1 inch	=	2'5400 cm.
1 metre	=	3'281 ft.
1000 ft. <sup>3</sup>	=	28'317 m. <sup>3</sup>
1 m. <sup>3</sup>	=	35'31 ft. <sup>3</sup>
1 m. <sup>3</sup>	=	220'0 gallons.
1 gallon	=	4'5460 litres.
1 in. <sup>3</sup>	=	16'387 cm. <sup>3</sup>
1 lb.	=	453'6 grams.
1 gram.	=	15'432 grains.
1 atmosphere	=	14'690 lbs./in. <sup>2</sup>
1 C.H.U.	=	1'800 B.T.U.
1 ft. <sup>3</sup> atm.	=	1'511 C.H.U.
1 K.W.H.	=	1255 ft. <sup>3</sup> atms.
1 K.W.H.	=	860'2 kilo. calories.
1 K.W.H.	=	1896 C.H.U.
1 H.P.H.	=	0'746 K.W.H.
1 H.P.H.	=	936'0 ft. <sup>3</sup> atms.
1 H.P.H.	=	1415 C.H.U.
1 lb. coal	=	about 7000 C.H.U.
1 lb. coke	=	about 8000 C.H.U.
0'25d./K.W.H.	=	£9.12/K.W. Years.

## REFERENCES.

- General Theory.**—Travers, "The Experimental Study of Gases." London, 1901.  
 Chwolson, "Traité de Physique." Paris, 1906-13.  
 Haber, "Thermodynamics of Technical Gas Reactions." London, 1908.  
 Nernst, "Experimental and Theoretical Applications of Thermodynamics to Chemistry." London, 1907.  
**Gas Analysis.**—Lunge, "Technical Gas Analysis." London, 1914.

**Heat Transfer.**—Hausbrand, "Verdampfen, Kondensieren und Kühlen." Berlin, Fünfte Auflage, 1912.

**Physical Constants.**—The values in the table are partly selected from Landolt-Börnstein-Roth, "Physikalisch-Chemische Tabellen." Berlin, Vierte Auflage, 1912, and from Kaye and Laby, "Physical and Chemical Constants," London, Third Edition, 1918. Many values, however, are taken from the original sources, and special reference may be made to the following:—

*Specific Heats of Oxygen, Nitrogen and Hydrogen at Constant Pressure:*

Scheel and Heuse, *Annalen* [4], 40, (1913) 473, 492; Escher, *Annalen*, [4], 42, (1913), 761.

*Specific Heats of Nitrogen and Carbon Dioxide at Constant Volume:* Crofts, *Chem. Soc. Trans.*, (1915), 290.

*Critical Temperatures and Pressures of Oxygen, Nitrogen, Hydrogen, Carbon Monoxide and Methane:*

Cardoso, *J. Chim. Phys.*, 13, (1912), 312; Bulle, *Physikal. Zeits.*, 14, (1913), 860.

*Thermal Conductivity:*

Weber, *Annalen*, [4], 54, (1917), 325, 437.

*Boiling and Melting Points:*

Table of melting points and standard temperatures issued by the American Bureau of Standards, *J. Soc. Chem. Ind.*, (1919), 67 R.

**General References.**—Thorpe, "A Dictionary of Applied Chemistry." London, 1912.

Martin, "Industrial Gases." London, 1916.

Roscoe and Schorlemmer, "Treatise on Chemistry." London, 1911.

Molinari, "Treatise on General and Industrial Chemistry," vol. 1., Inorg. (Feilmann). London, 1912.

## PART I.—THE GASES OF THE ATMOSPHERE

### SECTION I.—AIR

**Properties of Air.**—In view of the complex nature of air it is not proposed to enter, at this stage, into a discussion of its properties, as these are best defined by a consideration of the following sections; the more important physical constants will be found in Table 12, pp. 53-5.

According to Holborn and Austin (*Sitzungsber. Kgl. Preuss. Akad. Wiss.*, (1905), 175), the mean specific heat at constant pressure varies with temperature as follows:—

Temperature ° C.	$C_p$
20-440	0·2366
20-630	0·2429
20-800	0·2430

According to Witkowski, the mean value of  $C_p$  between  $-102^\circ$  C. and  $17^\circ$  C. is 0·2372.

The influence of pressure over the range 1-300 atms. on the specific heat is seen from the formula given by Holborn and Jakob (*Z. Verein. deut. Ing.*, **61**, (1917), 146) for a temperature of  $60^\circ$  C.—

$$10^4 C_p = 2414 + 2\cdot86p + 0\cdot0005p^2 - 0\cdot0000106p^3$$

$p$  being in atmospheres.

**Composition of the Atmosphere.**—The composition of the atmosphere is not absolutely constant, but the following table will serve to indicate the general composition, according to the most recent experiments. It is obvious that the

atmosphere is by no means such a simple mixture as is sometimes imagined.

TABLE 15.  
COMPOSITION OF THE ATMOSPHERE.

<i>Component.</i>	<i>Percentage (by volume).</i>
Nitrogen .. .. .	78·05
Oxygen .. .. .	21·0
Argon .. .. .	0·93236
Neon .. .. .	0·00181
Helium .. .. .	0·00054
Krypton .. .. .	0·000049
Xenon .. .. .	0·0000059
Carbon dioxide .. .. .	0·03-0·3
Hydrogen .. .. .	0·019 *
Methane .. .. .	0·0121 *
C <sub>6</sub> H <sub>6</sub> and similar hydrocarbons .. .. .	0·0017 *
Carbon monoxide, together with hydrocarbons of the type C <sub>n</sub> H <sub>2n-2</sub> and C <sub>n</sub> H <sub>2n</sub> .. .. .	0·0002 *
Formaldehyde .. .. .	0·002-0·005
Ozone .. .. .	} Variable traces
Hydrogen peroxide .. .. .	
Ammonia .. .. .	
Nitric acid, oxides of nitrogen .. .. .	
Sulphur compounds .. .. .	
Chlorine compounds .. .. .	
Water vapour .. .. .	Variable

The percentage of oxygen is not quite constant, but varies slightly according to the locality and the altitude; the maximum variations being of the order of 0·1 %. The carbon dioxide content is usually about 0·03 %, rising to some two or three times this value in towns during fogs, while in badly ventilated rooms the concentration may rise to about 0·3 %.

In this connection it is interesting to note that the composition of exhaled air is somewhat as follows:—

	Per cent.
Nitrogen .. .. .	79·1
Oxygen .. .. .	16·5
Carbon dioxide .. .. .	4·4
	<hr/> 100·0

\* The values marked with an asterisk are due to Gautier (*Annales de Chim. et de Phys.*, [7], 22, (1901), 5). Rayleigh gives a lower value for hydrogen, viz. 0·003 %. The presence of the oxygen-nitrogen compounds is probably due to electrical action, while the sulphur compounds are mostly derived from household and industrial contamination. A certain amount of sodium chloride is to be found in suspension in the atmosphere in the neighbourhood of the coast.

### The Liquefaction of the Permanent Gases (Air).

The liquefaction of permanent gases is a subject which claimed the attention of scientists and inventors for many years before any degree of success was attained.

A permanent gas is distinguished from a vapour in that the critical temperature of the former is below the ordinary temperature, that of the latter above. With gases of the latter category, of which sulphur dioxide and carbon dioxide may be taken as representative examples, the mere application of sufficient pressure at the ordinary temperature is all that is required to produce liquefaction. When one considers that the critical temperatures of nitrogen and oxygen are  $-145^{\circ}$  C. and  $-118^{\circ}$  C. respectively (as was subsequently discovered), the difficulties encountered by the early experimenters are not surprising. Progress was facilitated by Cailletet's discovery, in 1877, of the principle of cooling by adiabatic expansion through the (accidental) sudden expansion of compressed acetylene in a glass tube, with the momentary formation of a mist. Repetition with oxygen and nitrogen (at a pressure of 200 atmospheres) and even with hydrogen (at 300 atmospheres), employing a constant external temperature of  $-28^{\circ}$  C., yielded a similar result.

The cooling effect of adiabatic expansion is expressed by the formula—

$$\frac{T_1}{T_2} = \left(\frac{P_1}{P_2}\right)^{\frac{\gamma-1}{\gamma}} \quad (\text{cf. p. 35})$$

Although of great scientific interest, these brilliant experiments contributed but little to the practical solution of the problem of liquefying permanent gases in bulk. Some further progress was made by Pictet, the so-called "cascade" method being employed. Carbon dioxide was first liquefied under slight pressure at a temperature of  $-65^{\circ}$  C., produced by the ebullition of liquefied sulphur dioxide under reduced pressure. The carbon dioxide was in turn evaporated under diminished pressure, yielding a

temperature of  $-130^{\circ}$  C., and was then used to cool a tube supplied with oxygen at a pressure of some 300 atmospheres. On opening the exit valve a transient stream of liquid was observed; here again the yields were very minute. By the evaporation of liquid ethylene, care being taken to provide efficient thermal insulation, Olszewski and Wróblewski, in 1885, obtained a temperature of  $-152^{\circ}$  C., at which temperature both oxygen and nitrogen were liquefied under pressures in the neighbourhood of 25 atms. The cascade method was elaborated further by Kammerlingh Onnes, using, (1) methyl chloride, (2) ethylene, and (3) oxygen. By the evaporation of the oxygen under reduced pressure a temperature of  $-200^{\circ}$  C., was reached and, finally,  $-270^{\circ}$  C. was realized by the addition of (4) a helium system.

The problem of producing liquid air technically was solved almost simultaneously by Hampson in England (B.P. 10165/95), Linde in Germany (B.P. 12528/95), and by Tripler in America (B.P. 15235/99). All these investigators made use of the Joule-Thomson Effect (cf. p. 10), in conjunction with the principle of the heat-interchanger first propounded by Siemens in 1857.

This effect is not to be confused with the adiabatic expansion of a gas performing external work; the fall in temperature being mainly due to the internal work involved in the separation of the molecules.

The approximate fall in temperature in the case of air can be evaluated from the expression—

$$dT = 0.276(p_1 - p_2) \left( \frac{272}{T} \right)^2 \text{ degrees C.}$$

where  $p_1$  and  $p_2$  are the initial and final pressures respectively, when  $p_1$  is not far removed from atmospheric pressure.

When this property of imperfect gases is utilized in conjunction with the principle of heat-interchange one obtains a progressive fall in the temperature of the expanded air until the point of liquefaction is reached.

**Theory of Cooling by the Joule-Thomson Effect.**—Some reference to the Joule-Thomson Effect has been made

on p. 10 in the Introduction, but a more complete examination will be necessary for a thorough understanding of air on liquefaction processes.

Consider a volume of gas  $v_0$  under a pressure of  $p_0$  atmospheres at an (absolute) temperature of  $T_0$ . Let the gas be compressed to a higher pressure  $p_1$  at a temperature  $T_1$  (the volume becoming  $v_1$ ). Imagine the compressed gas at pressure  $p_1$  to be disposed in a cylinder A (Fig. 5), closed by a frictionless piston B, which is kept in position by another frictionless piston F of suitable area exposed to a

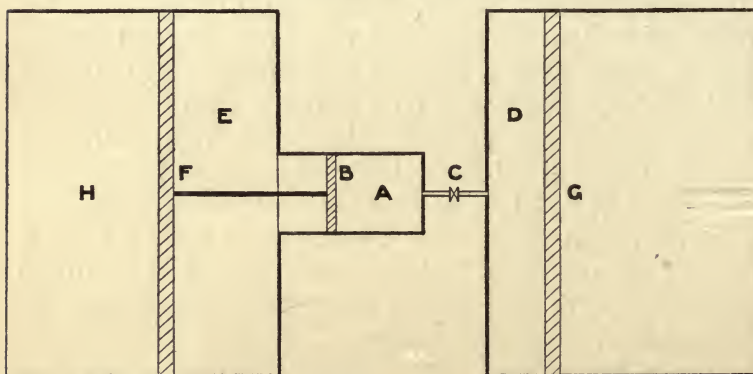

FIG. 5.—Production of cold by the Joule-Thomson Effect.

constant pressure  $p_2$  on the side marked H (e.g. in contact with the atmosphere), the space E being vacuum. By means of the valve C the gas is allowed to expand to pressure  $p_2$  into the cylinder D, closed by a frictionless piston G working against a pressure  $p_2$ . We will suppose, further, that any temperature change which may occur on expansion is rectified in the course of passage through the connecting tube so that the whole operation is isothermal.

Now the work performed by the gas on the piston  $G = p_2 v_2$ , while that performed by the piston B on the gas (= work performed by the gas at H on the piston F)  $= p_1 v_1$ .\*

\* In actual practice, this work  $p_1 v_1$  is performed by the piston of the compressor in addition to that demanded by the actual compression of the gas. Since, however, the compressor is fed with gas at pressure  $p_2$ , the power absorbed by the compressor is approximately equal to that calculated on pp. 34-9.



Since most gases show a greater or less deviation from Boyle's Law,  $p_1v_1$  is not necessarily equal to  $p_2v_2$ , and the work performed by the system on the external gas at pressure  $p_2$  (which will generally be one atmosphere)

$$\Rightarrow p_2v_2 - p_1v_1 = H_e$$

$H_e$  representing the cooling (or, if negative, the heating) produced by external work. In addition, we have to consider the internal work due to the separation of the molecules, which will, in all cases, operate in the direction of producing a cooling effect ( $H_i$ ).

$$H_i = - \int_{v_2}^{v_1} \frac{a}{v^2} \cdot dv = - \frac{a(v_1 - v_2)}{v_1v_2}$$

when  $a$  is the constant representing the cohesion of the molecules in Van der Waals' equation—

$$(p + a/v^2)(v - b) = KT$$

Now  $a$  may be derived from the following relation (cf. p. 7):—

$$a = \frac{27}{64p_c} \left( \frac{p_0v_0T_c}{T_0} \right)^2$$

$T_c$  and  $p_c$  being the critical temperature and pressure respectively. Thus, in the case of air, if we take as units cubic feet and atmospheres and consider a volume of 1000 ft.<sup>3</sup> measured at 1 atm. pressure and 15° C., *i.e.*  $p_0 = 1$ ,  $v_0 = 1000$ ,  $T_0 = 288$ ,

$$a = \frac{27}{64 \times 39} \left( \frac{1000 \times 133}{288} \right)^2 = 2307$$

We will now consider the cooling effect in C.H.U. (cf. p. 12) of an expansion of this mass of air from 200 atms. (absolute) to 1 atm. at a temperature of 15° C., assuming the temperature to be kept constant by external supply or abstraction of heat.

$$\begin{array}{llll} \text{Now for } 15^\circ \text{ C. and } 1 \text{ atm.} & p_0v_0 = p_2v_2 = 1000 & & \\ \text{,, ,, ,, } & 200 \text{ ,, } & p_1v_1 = \frac{1000 \times 1.0855}{1.0587} & \\ & & = 1025.3 & \end{array}$$



*Expansion at  $-100^{\circ}$  C.*—We will next consider the effect of performing the above isothermal expansion after a preliminary cooling of the compressed gas to, say,  $-103^{\circ}$  C., down to which temperature the  $pv$  values have been determined by Witkowski (*loc. cit.*, cf. Table 2, p. 6). This is about the temperature to which the air is cooled before expansion in the simple type of machine such as the Hampson plant (cf. Bradley and Hale, *Physical Review*, **19**, (1904), 391); the temperature does not fall below the critical temperature and, consequently, no liquefaction occurs before expansion.

As Witkowski's experiments were not extended to pressures exceeding 130 atms., we will take the values at this pressure.

Considering, as before, 1000. ft.<sup>3</sup> of air at  $15^{\circ}$  C. and 1 atm. (in these calculations Witkowski's values are multiplied by 273/288, since  $p_0v_0$  is taken at  $15^{\circ}$  C.)

for	$15^{\circ}$ C. and 1 atm.	$p_0v_0 = 1000$
	$-103.5^{\circ}$ C. ,, 1 ,,	$p_2v_2 = 587.9$
	$-103.5^{\circ}$ C. ,, 130 ,,	$p_1v_1 = 377.4$

We have thus a very considerable deviation from perfection, the gas being now more compressible than a perfect gas; consequently  $H_s$  will be positive.

$$\begin{aligned} H_s &= p_2v_2 - p_1v_1 = 587.9 - 377.4 \text{ ft.}^3 \text{ atms.} \\ &= 210.5 \text{ ft.}^3 \text{ atms.} = 318.1 \text{ C.H.U.} \end{aligned}$$

$$H_i = -\frac{a(v_1 - v_2)}{v_1v_2} = -\frac{2307\left(\frac{377.4}{130} - 587.9\right)}{377.4 \times 587.9} \text{ ft.}^3 \text{ atms.}$$

$$= \frac{2307 \times 585.0}{1706.7} \text{ ft.}^3 \text{ atms.}$$

$$= 791 \text{ ft.}^3 \text{ atms.} = 1195 \text{ C.H.U.}$$

Total cooling effect, therefore,

$$= 1195 + 318.1 \text{ C.H.U.} = 1513 \text{ C.H.U.}$$

A similar calculation for the expansion of the same quantity of air from 130 atms. to 1 atm. at a temperature

of  $15^{\circ}$  C. gives a corresponding cooling effect of 470 C.H.U. ( $H_e = 15.4$  C.H.U. ;  $H_i = 454.3$  C.H.U.)

The cooling effect is thus found to be considerably greater at the lower temperature.

Turning to the actual practical operation of liquid air plants, it should be noted that the above observed difference of  $1513 - 470$  C.H.U. ( $= 1043$  C.H.U.) is not usefully available for the production of liquid air, since the additional cooling effect is balanced exactly by the extra heat evolution in the heat-interchanger of the incoming gas ; this prevents the temperature of the compressed gas arriving at the expansion valve from falling below about  $-100^{\circ}$  C. The additional cooling is absorbed in lowering the temperature of the expanded gas to that at which the cold gas enters the interchanger, viz. the boiling point of air. It would only be available if the compressor were operated at the same temperature of  $-103^{\circ}$  C. Consequently, the value of  $pv$  at the temperature of entry of the compressed gas into the interchanger, or, more strictly, the difference between the values of  $pv$  for the gases entering and leaving the interchanger respectively, assuming the heat-interchange to be perfect, determines the amount of cooling produced. Since the heat-interchange is not perfect the heat required to heat up the exit gases to the inlet temperature must be deducted from the cooling effect.

We shall see later the effect of a preliminary pre-cooling of the gas.

The heat evolution of the incoming compressed gas, alluded to above, has the effect of making the temperature gradient between the two fluids in the heat-interchanger increase as the temperature falls. Obviously, the growing imperfection of the compressed gas will be accompanied by an increase in the specific heat, the effect being very marked near the critical temperature at high pressures.

The outcome of the above considerations is, that we get the same cooling effect with a low temperature expansion, accompanied by a considerable fall in temperature, as in the example given above, in which a temperature of  $15^{\circ}$  C.

and isothermicity were assumed. Consequently, we may take the cooling effect under actual working conditions as being of the order of 638 C.H.U. for a working pressure of 200 atmospheres.

When liquefaction sets in the external work performed on the atmosphere by the issuing air diminishes. The decrease is compensated for, however, by the absorption of heat due to external work performed by the air which escapes liquefaction on the portion liquefied.

We have already seen that the power expenditure is of the order of 10 K.W.H. per 1000 ft.<sup>3</sup> of air compressed. Therefore, cooling effected by 1 K.W.H. (measured on the switchboard) = about 64 C.H.U., equivalent to the production of about 0.29 litre of liquid air. The above estimate is, of course, based on the (incorrect) assumption that there are no thermal losses; the efficiency falls off in proportion to the extent of such leakages.

Before leaving the subject it will be worth while to examine the case of hydrogen, which, as stated above, gives a heating effect at the ordinary temperature.

*The case of Hydrogen.*—Taking 1000 ft.<sup>3</sup> of hydrogen at 15° C. and 1 atm. and, after compression to 200 atms. (absolute), expanding to 1 atm., we have—

$$H_e = p_2 v_2 - p_1 v_1 = 1000 - \frac{1000 \times 1.198}{1.056} \text{ ft.}^3 \text{ atms.}$$

$$= 1000 - 1134 \text{ ft.}^3 \text{ atms.}$$

$$= -134 \text{ ft.}^3 \text{ atms.} = -202 \text{ C.H.U.}$$

$$a = \frac{27}{64 \times 11.0} \left( \frac{1000 \times 31.95}{288} \right)^2 \quad \text{taking } p_e \text{ as equal to } 11.0 \text{ atms.}$$

$$= 472$$

$$H_i = \frac{472 \left( \frac{1134}{200} - 1000 \right)}{\frac{1134 \times 1000}{200}} \text{ ft.}^3 \text{ atms.}$$

$$= \frac{472 \times 994.3}{5670} \text{ ft.}^3 \text{ atms.}$$

$$= 82.8 \text{ ft.}^3 \text{ atms.} = 125 \text{ C.H.U.}$$

Therefore total cooling effect

$$= -202 + 125 \text{ C.H.U.} = -77 \text{ C.H.U.}$$

Heating effect per atm. pressure drop =  $\frac{77}{18.20 \times 199} \text{ }^\circ \text{C.}$

(since specific heat = 18.20 C.H.U./1000 ft.<sup>3</sup>/°C.)

$$= 0.0213 \text{ }^\circ \text{C.}$$

The value determined experimentally by Joule and Thomson was 0.03° C. for 6.8° C. and pressures near atmospheric; if the above calculation be repeated for 20 atms. the value obtained is 0.018, not greatly different since the *p**v* curve is practically a straight line between 1 and 200 atms.

As the temperature is lowered,  $H_g$  decreases and  $H_l$  increases owing to the growing imperfection of the gas, with the consequence that at -80.5° C. an inversion point is reached; below this temperature a cooling effect sets in, but is not very marked until the temperature is lowered to the neighbourhood of -200° C. It is found necessary to pre-cool to this temperature before the liquefaction of hydrogen can be effected by the Joule-Thomson effect. The beneficial influence of pre-cooling will be discussed under the Linde process of air liquefaction.

The final improvement in the liquefaction of permanent gases was suggested by Siemens, while its technical development is due to Claude, who overcame the difficulties of employing expansion accompanied by the performance of external work. With this system of working it is important not to allow the temperature to fall below about -140° C., as the increase in the specific heat, in conjunction with the diminished amount of external work which the gas is capable of performing at lower temperatures owing to its rapidly increasing compressibility, leads to low efficiencies. A more detailed account will now be given of the principal systems of making liquid air.

As regards patents relating to this subject, the number is so great and the differences in many cases so involved that it is impossible in the present volume to do more than give a *resumé* of the salient features of those which have assumed commercial importance.

## MANUFACTURE OF LIQUID AIR

## Useful Constants

Weight of 1000 ft.<sup>3</sup> of air at 15° C. and 1 atm. pressure = 76.49 lbs.

Weight of 1 litre of liquid air = about 1 kilo.

Volume of 1 litre of liquid air when vaporized = about 28 ft.<sup>3</sup> at 15° C. and 1 atm.

Heat units which must be abstracted for the production of 1 litre of liquid air from atmospheric air = about 220 C.H.U.

## Hampson System

The Hampson system is a convenient one for laboratory use, being usually supplied in 5 K.W. sets which furnish about 1 litre of liquid air per hour, equivalent to the abstraction of about 44 C.H.U./K.W.H. Although somewhat inefficient, it possesses an important advantage for such experimental purposes in its simplicity. Air is compressed to 175-200 atmospheres, being first freed from carbon dioxide by passage over a series of trays filled with lime. After depositing the lubrication water in a separator, the gases are freed from residual traces of carbon dioxide and water vapour in a purifier, consisting of a steel cylinder charged with sticks of caustic potash, and are then allowed to expand at a fine adjustment valve, finally flowing through a heat-interchanger back to the compressor.

Some 5 % of the compressed air is liquefied at each cycle when the apparatus has once become thoroughly cooled down. Complete removal of the carbon dioxide and water vapour is important, as otherwise blockages may occur in the liquefier. Working for about 10 minutes is sufficient for the production of liquid air to commence.

The apparatus, as made up by the British Oxygen Co., is shown in Fig. 6. The compressed air entering at A traverses the heat-interchanger coils B, and undergoes expansion at the valve C, which is adjusted by the hand wheel E. After expansion, the air passes over the coils, its path being determined by baffles, to the outlet F. The level

of the liquid in the receiver, which holds some 100 c.c., is indicated by the glycerol gauge H; the liquid air is periodically withdrawn by the valve T. A thick layer of lagging, *e.g.* sheeps' wool, is disposed around the central portion.

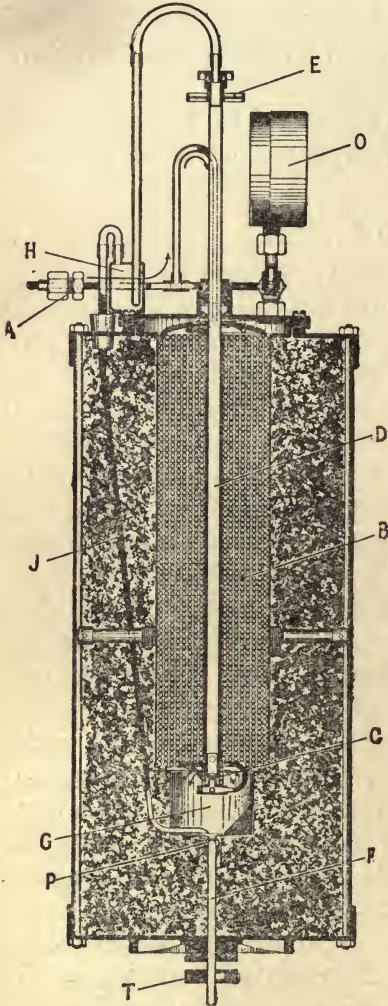
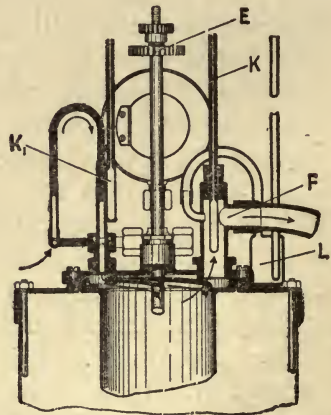

FIG. 6.—Hampson Liquefier (British Oxygen Co.).

### Linde System

The Linde system (cf. B.P. 14111/02) is perhaps the system most commonly used in large scale practice. It differs from the simple Hampson process, quite apart from constructional details. In the first place, instead of expanding the air from 200 atms. to 1 atm., Linde expands only from 200 atms. to about 50 atms. We will examine the diminution in the cooling effect as com-



pared with the decrease in the power expenditure.

We have seen that with an expansion from 200 atms.



(absolute) to 1 atm., the cooling is of the order of 638 C.H.U. for the expansion of 1000 ft.<sup>3</sup> of air measured at 15° C. and 1 atm. In the present case—

$$p_1 v_1 = 1025.3 \text{ at } 200 \text{ atms. and } 15^\circ \text{ C.}$$

$$p_2 v_2 = 983.3 \text{ at } 50 \text{ atms. and } 15^\circ \text{ C.}$$

Therefore  $H_e = (p_2 v_2)_{15} - (p_1 v_1)_{15}$   
 $= 983.3 - 1025.3 \text{ ft.}^3 \text{ atms.}$   
 $= -42 \text{ ft.}^3 \text{ atms.} = -63.5 \text{ C.H.U.}$

$$H_i = \frac{-a(v_1 - v_2)}{v_1 v_2} \text{ ft.}^3 \text{ atms.}$$

$$= \frac{-2307 \left( \frac{1025.3}{200} - \frac{983.3}{50} \right)}{\frac{1025.3 \times 983.3}{200 \times 50}} \text{ ft.}^3 \text{ atms.}$$

$$= \frac{2307 \times 14.542 \times 10,000}{1025.3 \times 983.3} \text{ ft.}^3 \text{ atms.}$$

$$= 332.7 \text{ ft.}^3 \text{ atms.} = 502.7 \text{ C.H.U.}$$

Total cooling effect = 502.7 - 63.5 C.H.U.  
 = 439.2 C.H.U.

The ratio of the above cooling to that obtained with the full expansion to 1 atm. = 439/638 = 1/1.45. The power expenditure will also be lower, as follows.

Assuming the compression to be adiabatic, the power varies as—

$$n \left\{ \left( \frac{p_1}{p_2} \right)^{\frac{0.29}{n}} - 1 \right\}$$

(cf. p. 38). In the present case we have: (1) single stage compression of  $\frac{1}{10}$ th of the air from 1 to 50 atms. (since about  $\frac{1}{10}$ th of the air is liquefied in each cycle); (2) single stage compression of the whole of the air from 50 to 200 atms. (absolute).

In the straightforward case we have compression of the whole of the air from 1 to 200 atms. (absolute) in, say, two stages (in large installations three-stage compressors are usually employed).

The ratio of the power expenditures will be—

$$\frac{0.1 \left\{ \left( \frac{50}{1} \right)^{0.2} - 1 \right\} + \left\{ \left( \frac{200}{50} \right)^{0.29} - 1 \right\}}{2 \left\{ \left( \frac{200}{1} \right)^{\frac{0.29}{2}} - 1 \right\}} = \frac{0.1 \times 2.11 + 0.495}{2 \times 1.56}$$

$$= \frac{1}{3.28}$$

Consequently, the ratio of output to power expenditure is increased by the Linde system of working in the proportion of  $3.28/1.45 = 2.26/1$ .

**Effect of Pre-cooling.**—Another improvement introduced by Linde consisted in the pre-cooling of the gas fed into the interchanger to, say,  $-35^{\circ}$  C., by means of an ammonia refrigeration system. As referred to above, the enhanced cooling effect produced by effecting the expansion at low temperatures is counteracted by the fact that the compressed gas arrives at the expansion valve at a temperature considerably above that of the cold gas entering the heat-interchanger. In other words, the thermal capacity of the compressed gas over the temperature range in question is much greater than that of the same volume of expanded gas. When liquefaction is in progress the cold air enters the regenerator at a fixed temperature, viz. that of the boiling liquid air; consequently the temperature at which the compressed gas reaches the expansion valve will be determined by the temperature at which it enters the interchanger, as well as by the degree of perfection of the interchanger.

If, therefore, the incoming compressed air, after being slightly cooled by the interchanger, be diverted therefrom, cooled to, say,  $-30^{\circ}$  C., by means of an ammonia or other system, and subsequently returned to the interchanger, the temperature of the gas arriving at the expansion valve will be lowered by an amount corresponding to the heat units abstracted by the auxiliary cooling plant. In consequence, an increased yield of liquid air will result. The exact procedure may be seen by reference to Fig. 7.

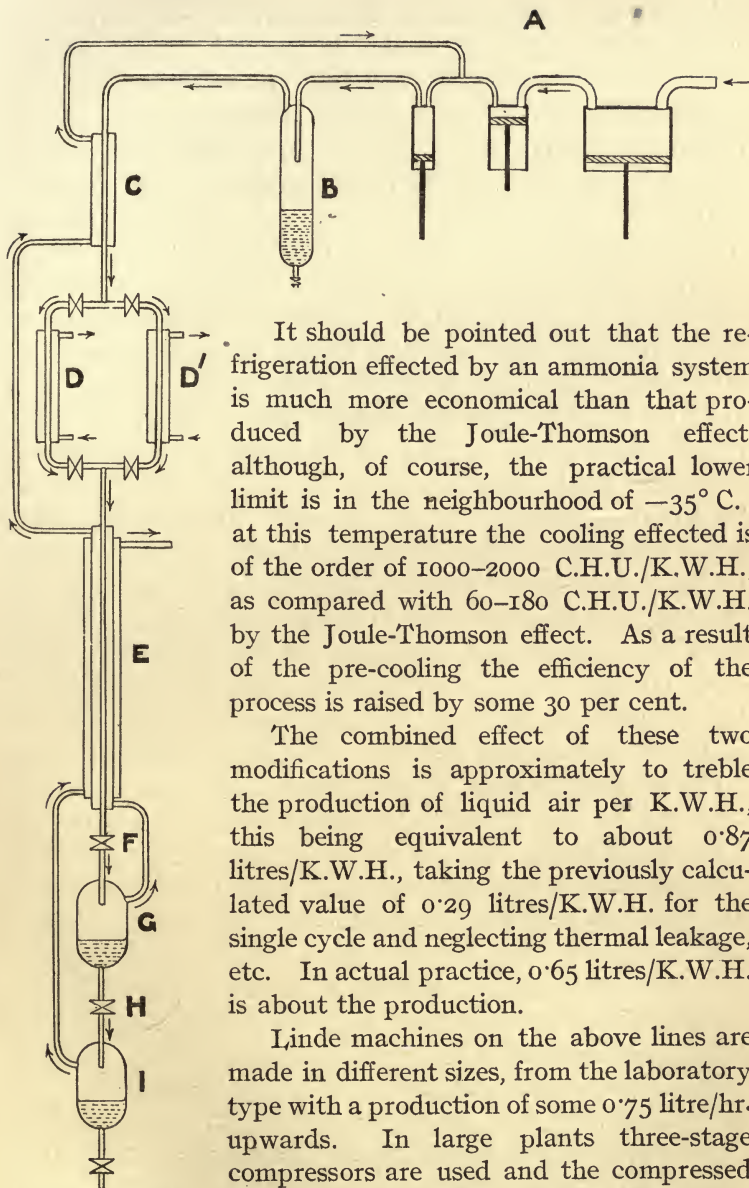

FIG. 7.—Linde System.

It should be pointed out that the refrigeration effected by an ammonia system is much more economical than that produced by the Joule-Thomson effect, although, of course, the practical lower limit is in the neighbourhood of  $-35^{\circ}\text{C}.$ ; at this temperature the cooling effected is of the order of 1000–2000 C.H.U./K.W.H., as compared with 60–180 C.H.U./K.W.H. by the Joule-Thomson effect. As a result of the pre-cooling the efficiency of the process is raised by some 30 per cent.

The combined effect of these two modifications is approximately to treble the production of liquid air per K.W.H., this being equivalent to about 0.87 litres/K.W.H., taking the previously calculated value of 0.29 litres/K.W.H. for the single cycle and neglecting thermal leakage, etc. In actual practice, 0.65 litres/K.W.H. is about the production.

Linde machines on the above lines are made in different sizes, from the laboratory type with a production of some 0.75 litre/hr. upwards. In large plants three-stage compressors are used and the compressed air, after separation of the lubrication water, is completely dried by cooling with

an ammonia refrigeration system to about  $-25^{\circ}$  C., using duplicate cooling systems, which are periodically changed over (three or more times weekly) in order to allow the deposited ice to thaw out. Before compression, the carbon dioxide is removed by means of towers fed with caustic soda solution. Traces of carbon dioxide are usually formed during the compression by the action of the air, heated by the adiabatic compression, on the packings of the pump.

The diagrammatic representation, Fig. 7, indicates the course of the compressed air. Passing from the compressor A, through the water separator B, and the preliminary heat-interchanger C, to one or other of the ammonia coolers D and D<sup>1</sup>, the dry gas enters the liquefier through the triple heat-interchanger E. (The actual interchanger consists of concentric spiral tubes.)

Arriving at the valve F, expansion to about 50 atmospheres takes place, the gas being returned to the last stage of the compressor. The air liquefied in the separator G, under a pressure of 50 atms., is allowed to expand to ordinary pressure through the valve H, suffering thereby partial evaporation; the gaseous fraction returns to the inlet of the compressor through the interchanger E. Liquid air is drawn off from the vessel I. The smaller sizes of plant, up to about 3 litres/hr. capacity, are fitted with two-stage compressors, in which case the expansion is from 200 atms. to about 20 atms.

The outputs and efficiencies of various sizes of plants are indicated in the following table:—

TABLE 16.  
LINDE LIQUID AIR PLANTS.

Litres of liquid air per hour with pre-cooling .. .. .	0·75	5	20	50	100
Litres of liquid air per hour without pre-cooling .. .. .	—	—	12·5	35	70
Power K.W. (measured on the switchboard) .. .. .	2·6	14·2	39	78	142
Litres/K.W.H. with pre-cooling	0·29	0·35	0·51	0·64	0·70
Litres/K.W.H. without pre-cooling .. .. .	—	—	0·32	0·45	0·49
Cooling water, gallons/hour .. .. .	55	308	835	1760	3300

### Claude System

The Claude system, as above indicated, depends on the cooling effect produced by expansion accompanied by external work, together with that due to internal work, the latter being, however, small compared with the former. Usually the working pressure does not exceed 40 atmospheres. The useful temperature limit which is reached by such expansion of compressed air in an engine cylinder is about  $-140^{\circ}$  C., and much of the initial difficulty in the working out of the process was due to this fact.

On account of the rapidly increasing imperfection of the air at this temperature in the direction of greater compressibility, expansion at a lower temperature is accompanied by relatively little work, the cooling effect produced by which may be balanced by the friction of the machine. This temperature is, however, about the critical temperature of air ( $T_c = -140^{\circ}$  C. ;  $p_c = 39$  atms.) ; consequently, by using the expanded gas to cool a receptacle supplied at 40 atms. pressure with air which has been pre-cooled in a temperature-interchanger, liquefaction of the high pressure air ensues (B.P. 27658/02). On release to the ordinary pressure, partial evaporation occurs and the temperature falls to  $-190^{\circ}$  C. By adjusting the height of the liquid in the liquefier-temperature-interchanger, and consequently the rate of liquefaction, the air arrives at the expansion engine at a temperature of about  $-100^{\circ}$  C.

Considerable trouble was at first experienced in the lubrication of the expansion cylinder, ordinary petrol being employed ; but recently it has been found that suitably treated leathers can be used without any lubrication.

By the Claude system, an output of about 0.75 litre of liquid air per K.W.H. (measured on the switchboard) is claimed. The general method of working may be explained further by reference to the diagrammatic representation, Fig. 8. Compressed air, at about 40 atms. pressure, enters through the heat-interchanger M, and suffers expansion

in the cylinder D, the engine being coupled, either mechanically or electrically, to the compressor. The cold expanded gases pass round the tubes of the second interchanger L, and cause the liquefaction of the compressed air supplied to the inside of the tubes, and finally leave through the interchanger M. The liquid air collects in the header at the bottom of the tubes and is drawn off in accordance with the temperature of the gas arriving at the expansion engine.

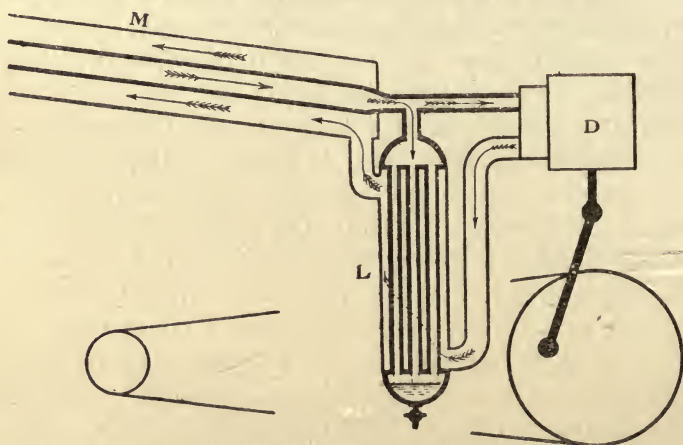

FIG. 8.—Claude Liquefaction System.  
(Claude's "Liquid Air, Oxygen and Nitrogen.")

A modification of this plan consists in effecting the expansion in two stages; in the first, the pre-cooled air is expanded in the cylinder, 35 (Fig. 9), so as to produce a temperature, *e.g.*  $-160^{\circ}$  C., well below the critical temperature. After producing the liquefaction of the compressed air in the temperature-interchanger, 24, 26, being warmed to from  $-130^{\circ}$  to  $-140^{\circ}$  C. in the process, the air undergoes a further expansion in 36, and in turn serves to liquefy the air in a second interchanger, 25, 27.

To avoid leaks of the very cold air, the two cylinders are arranged in tandem, only the low pressure cylinder having a stuffing box. It is claimed that a production of 0.9 litre/K.W.H. (measured on the switchboard) is attained in a moderately large plant.

The low working pressure and the rapidity in starting up of the Claude plant are both in its favour, and the general tendency of late years has been to instal Claude

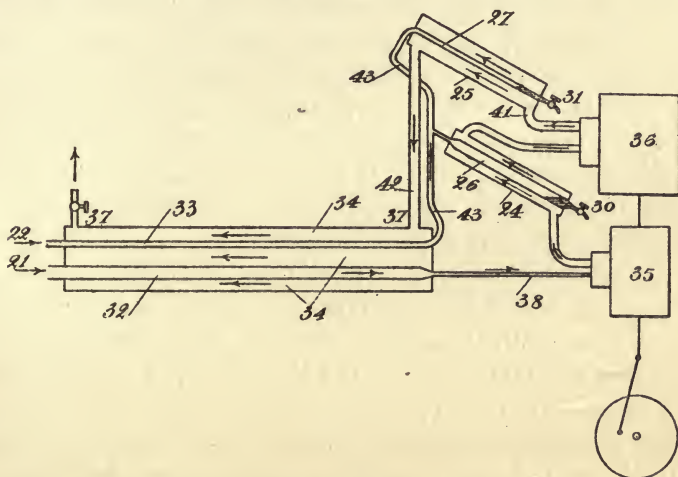

FIG. 9.—Claude Liquefaction System.

rather than Linde plants. The following table gives particulars of a few sizes of Claude plants:—

TABLE 17.  
CLAUDE LIQUID AIR PLANTS.

Production, litres/hr. . . . .	5	50	65
Power (measured on the switchboard) K.W.H.*	14	56	70
Litres of liquid air per K.W.H. . . . .	0·36	0·89	0·93

With reference to the possible effect of accumulations of solid argon, methane or acetylene in causing explosions in liquid air plants, cf. Bramkamp (*J. Soc. Chem. Ind.*, (1914), 240).

**Properties of Liquid Air.**—Liquid air is a mobile liquid with a pale blue colour, varying in intensity according to

\* According to Mewes (*Z. für Sauerstoff und Stickstoff Industrie*, 5, (1913), 317), the power figures given by Linde are the gross values read off on the switchboard, while Claude's figures apply to the power on the compressor shaft. Claude's figures have therefore been increased by 25 per cent., assuming 80 per cent. efficiency in the motor.

the oxygen content. Its density is about 1.0 and the boiling point varies from  $-183^{\circ}$  to  $-196^{\circ}$  C., according to composition (cf. p. 80).

Freshly liquefied air usually contains considerably more than 21 % of oxygen, e.g. 50–60 %; on standing, the oxygen content increases. The specific heat is about 0.5, while the latent heat of vaporization is about 50 calories per gram (*i.e.* per c.c.) = 50 C.H.U./lb. On cooling liquid air, nitrogen separates out at about  $-213^{\circ}$  C. in a comparatively pure state; the oxygen does not solidify until a temperature of  $-225^{\circ}$  C. is reached.

Liquid air has feeble magnetic properties on account of its oxygen content. Its refractive index ( $\mu_D$ ) is 1.2062. On mixing equivalent quantities of liquid nitrogen and oxygen, a contraction of about  $\frac{1}{2}$  % is observed, accompanied by a temperature rise of about  $0.5^{\circ}$  C.

**Applications of Liquid Air.**—The principal application of liquid air is in the manufacture of oxygen and nitrogen by fractionation. At the time of its first discovery, many fantastical claims were made for its application as a source of power, etc., but apart from the above, no very extensive use has been made of liquid air. A considerable advance in the possibility of the industrial use is due to the perfection of the metal vacuum vessel. Liquid air can be purchased (at about 5s. per gallon) in metal vessels holding up to about five gallons. These vessels are on the lines of the glass Dewar vessel, being furnished with a charcoal tube cooled by the liquid air, for the purpose of effecting the complete exhaustion of the jacket. For a discussion of certain explosions originating from the accidental breaking of liquid air vessels and the consequent contact of the contents with the charcoal, cf. Wöhler, *Chem. Zeit.*, Oct. 5, 1918. Liability to explode under these conditions is considered to depend on the presence of catalysts, such as iron oxide, in a highly absorptive charcoal.

Liquid air of about 60 % oxygen content is used in mine rescue apparatus, some five litres of liquid air being contained, absorbed in asbestos wool, in a vessel with only moderate



thermal insulation (kieselguhr) ; a slow evaporation results which supplies a stream of air to the breathing apparatus. The advantages over the similar apparatus employing compressed oxygen, are the comparative lightness (the weight is about 30 lbs.), length of action, and the greater ease of manufacture of liquid air, as compared with compressed oxygen, at the pit-head.

Numerous proposals have been made with regard to the use of liquid air in conjunction with carbonaceous matter or aluminium as an explosive. The usual method of application is to employ a cardboard cartridge with a perforated inner tube ; a mixture of kieselguhr and oil, or soot, etc., is inserted, the cartridge placed in the bore-hole and liquid air injected, after which the charge is fired electrically. This method was used in cutting the Simplon Tunnel. The chief advantages claimed are the absence of fumes and the lack of danger in case of a misfire, as the charge rapidly becomes innocuous. On the other hand, the necessity for firing very rapidly after charging and the difficulty of transportation and storage of the liquid air are against its general application.

**Separation of the Constituents of Liquid Air—Theoretical Considerations.**—As has already been pointed out, the principal application of liquid air is in the production of oxygen and nitrogen.

The separation of the constituents of liquid air by fractionation was propounded by Parkinson in B.P. 4411/92, but was first realized by Dewar.

To glance first at the theoretical side of the question, we are indebted to the work of Linde and to the more complete investigation of Baly (*Phil. Mag.*, **49**, (1900), 517), for the relation between the liquid and gaseous phases of nitrogen-oxygen mixtures, Fig. 10.

The curves indicate that starting with liquid air of 21 % oxygen content, the percentage of oxygen in the first fraction is about 7 %, rising as evaporation proceeds. It will be noticed that there is no mixture of maximum or minimum boiling point, and that, consequently, application

of ordinary fractionation column principles should result in effective separation as far as oxygen is concerned ; it is, however, impossible by simple fractionation to reduce the oxygen content of the nitrogen fraction to below 7 %. It will be seen later that this can be accomplished by special means.

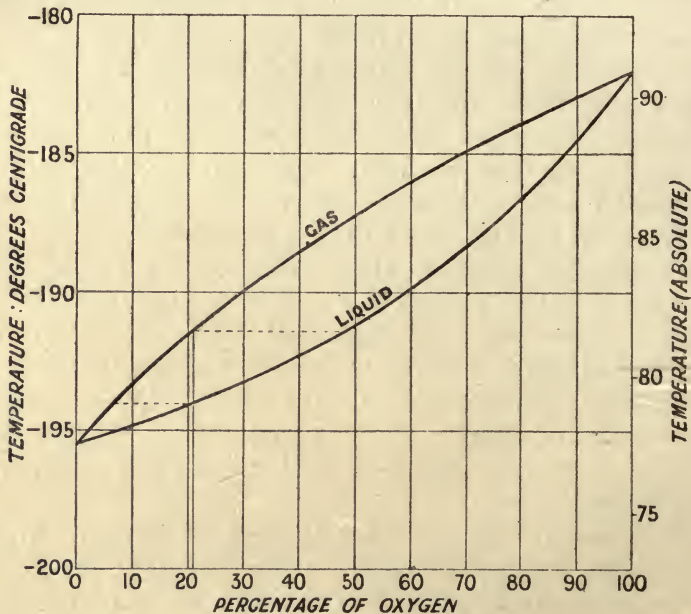

FIG. 10.—Baly's Curves for the liquid and gaseous phases of the system nitrogen-oxygen at atmospheric pressure.

As regards the minimum energy involved in the separation, it was indicated by Parkinson in the above patent that recuperation of the cold would be desirable, in which case only the losses in the heat-interchanger are involved, apart from the energy required for the actual separation of the gases, a factor liable to be overlooked. This latter quantity corresponds to the isothermal compression of the nitrogen to 0.79 of its original volume and of the oxygen to 0.21 of its volume, *i.e.* in each case—

$$\int_{v_2}^{v_1} p \cdot dv = p_1 v_1 \log_e \frac{p_2}{p_1} \quad (\text{cf. p. 38})$$

Taking for example, 1000 ft.<sup>3</sup> of air at 15° C. and 1 atm., the work involved is—

$$\begin{aligned} & 1000 \times 0.79 \times 2.3026 \times \log \frac{1.00}{0.79} \\ & + 1000 \times 0.21 \times 2.3026 \times \log \frac{1.00}{0.21} \text{ ft.}^3 \text{ atms.} \\ & = 514.0 \text{ ft.}^3 \text{ atms.} = \frac{514.0}{936.2} \text{ H.P.H.} \\ & = 0.549 \text{ H.P.H. per 1000 ft.}^3 \text{ of air.} \end{aligned}$$

Thus each 1000 ft.<sup>3</sup> of oxygen demands a minimum energy expenditure of—

$$\frac{0.549}{0.21} \text{ H.P.H.} = 2.61 \text{ H.P.H.}$$

As will be seen below, a considerably greater energy expenditure is demanded in practice. In order to effect the condensation of air by means of a bath of liquid air boiling under atmospheric pressure, a certain compression is required, increasing as the nitrogen boils off from the liquid bath. In practice, a compression of from 3 to 5 atmospheres is used. As regards losses in the heat-interchangers, we may take the efficiency as being of the order of 95 %.\*

We will now pass to the consideration of the different systems for the separation.

## MANUFACTURE OF OXYGEN AND NITROGEN

### Linde System

The principle of rectification was first applied technically by Linde in 1895 (cf. B.P. 12528/95), but the main features of the Linde plants, except the most recent, are to be found in B.P.s 14111/02 and 11221/03. Since the production of pure nitrogen together with impure oxygen requires a somewhat different procedure from that of the production of pure oxygen together with impure nitrogen, slightly different types of

\* According to Claude, one litre of liquid air is evaporated in the fractionation of the air corresponding to 30 litres of liquid air.

apparatus are used for the two purposes. It usually happens, unfortunately, that there are not adequate demands for both oxygen and nitrogen in large quantities in a given locality.

**Oxygen Plants.**—The operation of the plant consists of two stages: (1) cooling down the air and producing a sufficient quantity of liquid air; (2) fractionation of such liquid air with sufficient replacement to compensate for thermal leakages. Air, at a pressure of about 135 atms., passes through three small tubes in the heat-interchanger, consisting of the copper tube C (Fig. 11, cf. *Engineering*, 99, (1915), 155) containing the smaller copper tubes, in counter-current to the outgoing gases. After traversing the coils  $d_1$ , expansion occurs at the valve G, the cooled expanded gases being discharged through a rose-ended pipe,  $d_2$ . As cumulative cooling takes place, liquefaction ensues and liquid flows down the column A, and collects in the chamber B. Presently liquefaction occurs in the coils  $d_1$  themselves and the pressure of the incoming compressed air is reduced by gradually opening G. A steady stream of liquid now falls down the column A, being derived, for the greater part, at the expense of the partial evaporation of the accumulation in the chamber B. This stream of liquid meets the counter-current of gas from the chamber B, and mutual fractionation results.

As the liquid progresses down the column the temperature gradually rises and the oxygen content continually increases; consequently, the liquid reaching the bottom is practically pure oxygen, while the ascending gas loses oxygen until its oxygen content is equal to that in equilibrium with liquid air containing 21% oxygen, viz. 7%. This means that some 28% of the total oxygen goes off with the nitrogen. When a steady state is established the working pressure is about 50–60 atmospheres, and the gases leave at a pressure of about 5 lbs./in.<sup>2</sup>, sufficient to overcome the resistance of the heat-interchangers.

The oxygen leaves the apparatus at  $e_1$ . As in all similar apparatus, the preliminary purification of the air from water and carbon dioxide is very important. The water

is often removed by pre-cooling the air with an ammonia plant, using duplicate coolers which are changed over three or more times weekly; this procedure has the further advantage of increasing the efficiency. The separator

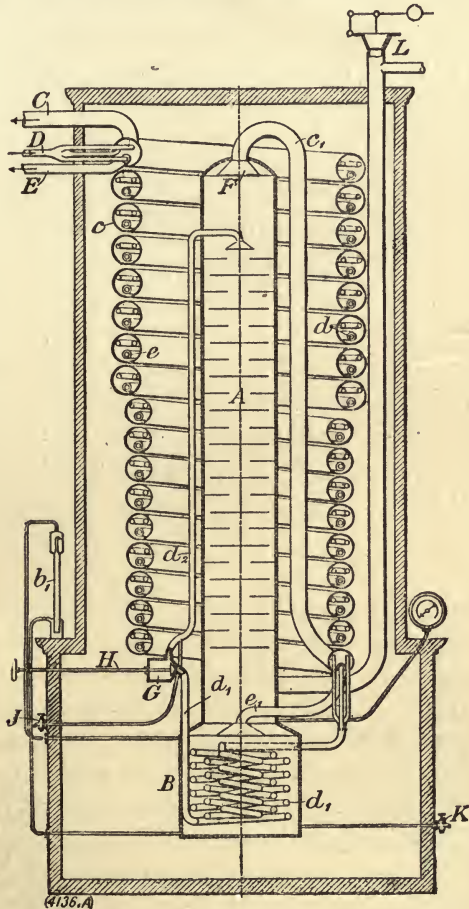

FIG. 11.—Linde Oxygen Plant (*Engineering*).

itself runs for about a week before blockage occurs; it is usually advisable to duplicate the separator in such plants. Instead of producing the liquid air in the separator itself, the latter may be fed with liquid air produced in an independent plant.

The Linde patent rights for the United Kingdom were acquired in 1906 by the British Oxygen Co., which now produces most of the oxygen used in this country by the Linde process. According to Murray, a usual size of plant is one absorbing 100 B.H.P. and producing about 1650 ft.<sup>3</sup> of oxygen per hour (*i.e.* 60 B.H.P.H. per 1000 ft.<sup>3</sup> oxygen, or, say, 53 K.W.H. if the efficiency of the motor = 85 %).

The following table gives particulars of various sizes of Linde plants as regards power expenditure, etc. :—

TABLE 18.  
LINDE OXYGEN PLANTS.

Oxygen production, ft. <sup>3</sup> per hour ..	35	70	175	350	700	1,750	3,500	7,000	17,500	35,000
Power (measured on the switchboard), K.W. ..	4.5	7.5	15	26	41	75	138	260	600	1,120
K.W.H./1000 ft. <sup>3</sup> of oxygen ..	129	107	86	74	59	43	39	37	34	32
Cooling water, gallons per hour ..	55	110	220	350	530	880	1,540	2,860	6,400	11,900

**Nitrogen Plants.**—The Linde nitrogen rectifier is very similar in general arrangement to that just described for oxygen production, and is shown in Fig. 12 (*cf. Engineering*, 99, (1913), 156). Two gas supplies are used : (1) air at an initial pressure of about 135 atms. to produce and maintain the charge of liquid air ; (2) air at a pressure of about 60 lbs./in.<sup>2</sup>. Pre-cooling may be used with advantage, and direct addition of liquid air may be substituted for (1). The liquid air resulting from (1) is fed to the top of the column while the low pressure air is led through coils in B, is there liquefied and then released through the valve G to the central portion of the column. In the column, as before, rectification takes place down to an oxygen content of 7 %, in which state of purity the nitrogen leaves the separator through the pipe C. The high pressure compressor is then fed with part of this effluent, with the result that the liquid at the

top of the column contains only 7% oxygen and can consequently reduce the oxygen content of the ascending gas to about 2%. In this way a cumulative rectification is produced and eventually the gas issuing at C is practically pure nitrogen.

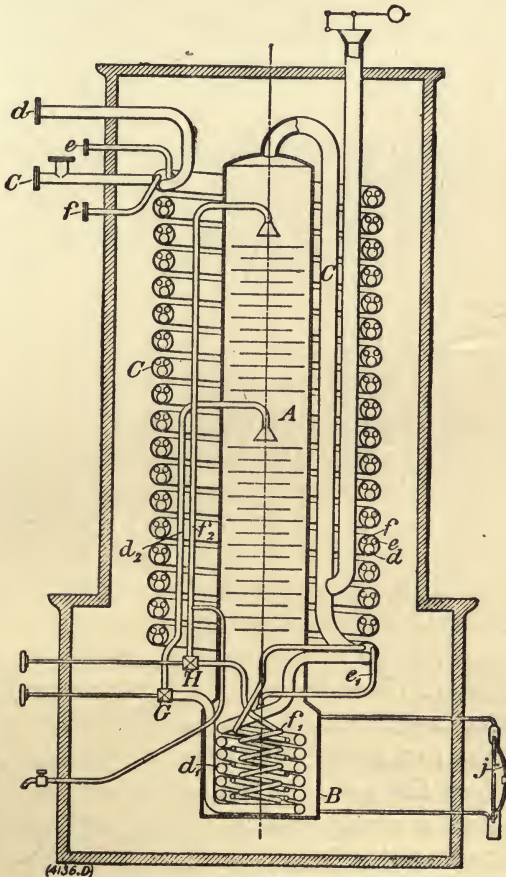

FIG. 12.—Linde Nitrogen Plant.

The purity of the oxygen fraction is often not very high. The power expenditure is about 14.2 H.P.H. per 1000 ft.<sup>3</sup> of nitrogen, according to Murray, equivalent to 12.4 K.W.H. per 1000 ft.<sup>3</sup> if efficiency of motor = 85%. One of the largest plants in operation before the war was that at the Cyanamide

Works at Odda, capable of producing 13,000 ft.<sup>3</sup> (0.43 ton) of nitrogen per hour.

The following table gives particulars of various sizes of Linde nitrogen plants :—

TABLE 19.  
LINDE NITROGEN PLANTS.

Nitrogen production, ft <sup>3</sup> per hr. ..	210	425	1,060	2,100	4,250	10,600	21,000	42,500	106,000	210,000
Power (measured on the switchboard). K.W. ..	4.5	9	22	39	60	112	205	373	820	1,490
K.W.H./1000 ft. <sup>3</sup> nitrogen	21.4	21.2	20.7	18.6	14.1	10.6	9.8	8.8	7.75	7.1
Cooling water. Gallons per hr. ..	165	198	330	570	880	1,650	2,820	4,400	8,360	16,500

**New Linde System.**—According to later Linde patents (D.R.P. 203814/06) rectification is pushed further by effecting a preliminary fractionation under about 4 atms. pressure, and thus obtaining a supply of liquid approximating to pure nitrogen for the final fractionation. Thus, column *b* (Fig. 13) is fed with air at about 4 atms. pressure at *a*. The oxygen-rich liquid collecting at the bottom of this column is taken to the vessel *e* at the top, the pressure being broken down to atmospheric at the valve *g*. As the gas inside the coil *c* is under a pressure of 4 atms., complete liquefaction will ensue, the first condensate being thus of 21% oxygen content. Since the gas in equilibrium with liquid of this composition at 4 atms. contains about 10% oxygen, the oxygen content of the liquid condensing in *c* will fall off and eventually almost pure nitrogen will result. A portion of the crude nitrogen from the top of *b* is led to the spiral *d* immersed in the tank *h* at the bottom of the low pressure column *k* and containing almost pure oxygen. Here liquefaction occurs, the liquid being led via the valve *i*, where the pressure is released, to the top of the column *k*, in which further rectification results. The oxygen-rich



liquid from *f* is vaporized in *e*, the vapours being led to the lower part of *k*. Pure nitrogen and oxygen leave the apparatus at *n* and *m* respectively. According to Martin, when worked specially for oxygen some 85–90 % of the oxygen is obtained as such. The energy consumption is about 37 K.W.H. per 1000 ft.<sup>3</sup> of oxygen. Similarly it is

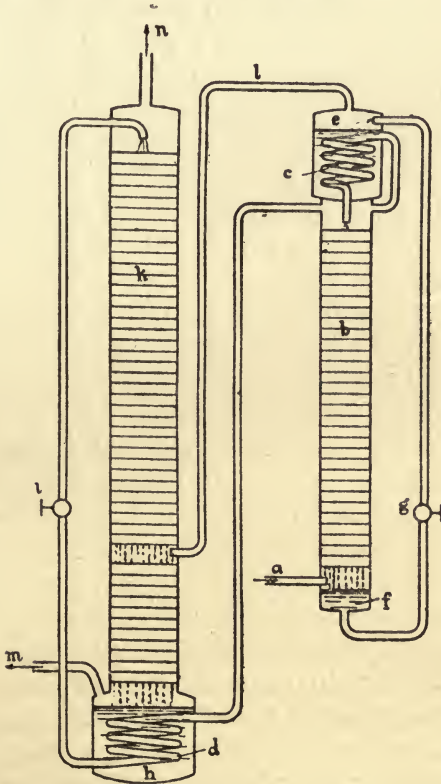

FIG. 13.—New Linde System.

possible to produce nitrogen of about 99·7 % purity with an energy expenditure of about 11·3 K.W.H. per 1000 ft.<sup>3</sup> of nitrogen.

### Claude System

In the Claude system the problem of feeding the fractionating column with a liquid poorer in oxygen than

that corresponding to ordinary air is attacked by effecting a preliminary rectification, employing what the inventor terms the "backward return," equivalent to a reflux condenser arrangement (B.P.s 16298/03, 26435/05, 17216/09, etc.). Thus, air at a pressure of about 40 atms. enters the apparatus through the heat-interchangers E and E<sup>1</sup> (Fig. 14), undergoing partial liquefaction in L, by heat-interchange with the cold gases leaving at the top of M. The residual air enters the rectification apparatus at A and undergoes partial liquefaction in passing up the tubes B, cooled externally by liquid air. Further liquefaction occurs in the downward path with the production of a nitrogen-rich fraction in A<sup>1</sup> while an oxygen-rich fraction collects in A. These two fractions are fed into the column at different levels, as in other systems.

The low temperature of the nitrogen issuing at G is utilized for a preliminary liquefaction of the incoming air at L, as explained above, while thermal leakage into the system is made good by expansion, with performance of external work, of part of the incoming air in the cylinder O. When admitted to the tubes B, the air is at a pressure of about 5 atms., suffering release to atmospheric pressure at R and R<sup>1</sup> respectively. Liquid air from an independent source may be used to charge the apparatus, or, in the latest types, the necessary charge is produced by the expansion device. The pressure at X ranges from about 40 atms., when filling up with liquid air, to a lower value in normal running, varying according to the size of the installation, and being as low as 18 atms. for large plants. The nitrogen obtained in this way contains in practice about 3 % oxygen. Nitrogen of a purity of 99.5 % upwards can, however, be obtained (B.P. 7175/10) by preventing the liquid dropping into the chamber surrounding the tubes B from mixing immediately with the main liquid therein, by disposing a separate tray round the upper part of the tubes B. Thus, the entering liquid, at a lower temperature than the main bulk of liquid because of lower oxygen content, is utilized to lower the oxygen content of the gaseous nitrogen. There are at

present a large number of plants in operation, the most usual sizes being 175–700 ft.<sup>3</sup> oxygen per hour.

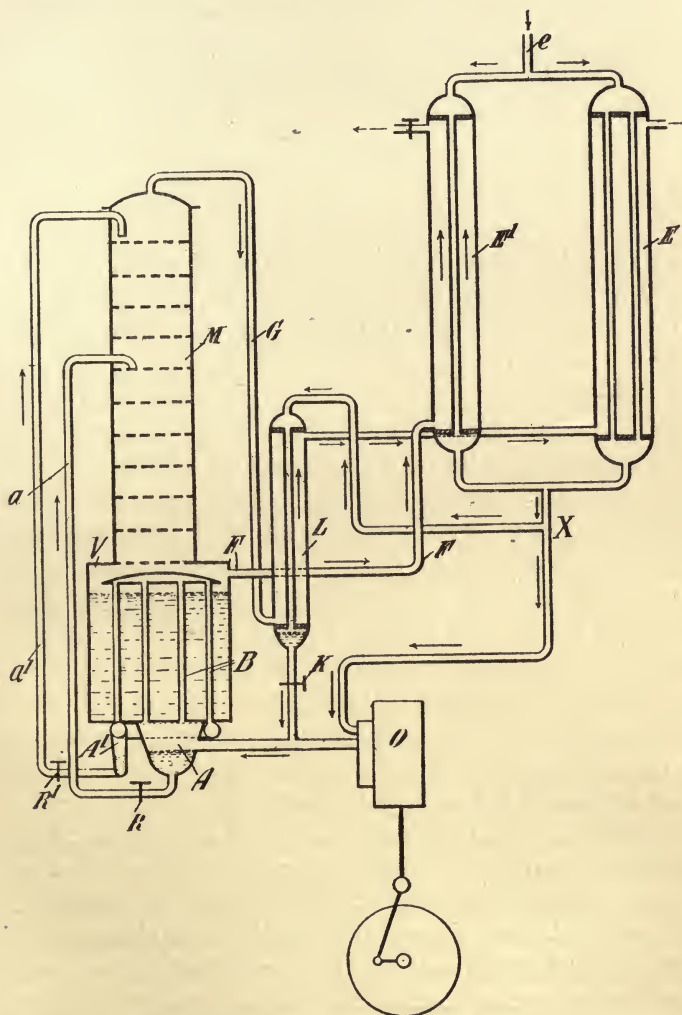

FIG. 14.—Claude Fractionation System.

The following table indicates the sizes and power requirements of Claude plants (cf. Mewes, *loc. cit.*, p. 77):—

TABLE 20.

## CLAUDE OXYGEN PLANTS.

Oxygen production, ft. <sup>3</sup> per hour ..	1,750	3,500
Power (measured on the switchboard). K.W. .. .. .	56	78
K.W.H./1000 ft. <sup>3</sup> of oxygen .. ..	32	22

## Pictet System

The Pictet system for oxygen and nitrogen (B.P.s 27463/10 and 9357/13; cf. Maxted, *J. Soc. Chem. Ind.*, (1917), 778), which is claimed to be very economical of power by reason of employing only an approximation to the minimum theoretical pressure for liquefaction, operates as follows. Cooled air, at practically atmospheric pressure, is led into the middle of a fractionating column (Fig. 15). A series of coils is arranged, in a number of separate systems, on the plates of the column and is supplied with compressed gas drawn by the pump *f* from the top of the column at which point the pressure is released from all the coils. Some liquid air being first placed in the column, liquefaction occurs in the coils and presently the gas leaving at the top will contain 7% oxygen. On liquefaction this will exert a further refining action on the ascending air and pure nitrogen will issue at the top of the column. The liquid collecting at the bottom of the column is practically pure oxygen.

In order to avoid the employment of more pressure than is necessary for the liquefaction and, further, to ensure uniform fractionation along the length of the column, the coils, as mentioned above, are divided into sections; the air is admitted at the bottom at a pressure of about 5 atms., while the uppermost section is fed with air only slightly above atmospheric pressure in accordance with the temperature gradient in the fractionation column, the pressure in each case being just sufficient to produce liquefaction of the nitrogen. The usual heat-interchangers are employed and the losses are made good by the liquefaction of part of the

issuing nitrogen by means of expansion with the production of external work.

A plant on this system, with a capacity of 14,000 ft.<sup>3</sup> of

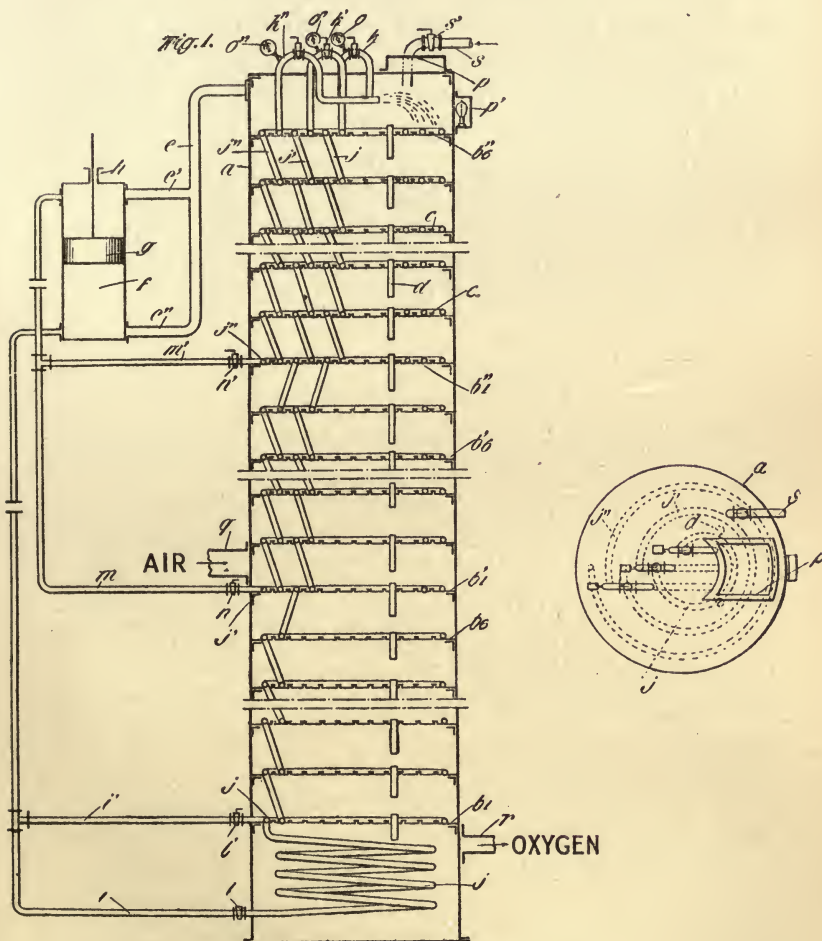

FIG. 15.—Pictet System.

nitrogen and 3500 ft.<sup>3</sup> of oxygen per hour, has been installed at the works of Gas Developments, Ltd., Walsall.

Among other systems of importance may be cited the Hildebrandt system, which, in general principle, does not

differ greatly from the Linde system. A Hildebrandt plant producing 350 ft.<sup>3</sup> of oxygen per hour absorbs about 27 K.W. in power.

**Separation of the Rare Gases.**—In the ordinary operation of liquid air fractionation plants, the rare gases divide themselves between the oxygen and nitrogen according to their boiling points. Thus, the oxygen fraction contains a higher concentration of argon than the nitrogen fraction, while the nitrogen fraction is richer in neon and helium. By means of suitable additional fractionation arrangements it is possible to separate the rare gases individually in a state of much greater concentration, and some account of such methods will be found under the rare gases.

#### REFERENCES TO SECTION I

- Claude, "Liquid Air, Oxygen, Nitrogen" (Cottrell). London, 1913.  
 Kausch, "Die Herstellung, Verwendung und Aufbewahrung von flüssiger Luft." Weimar, Fourth Edition, 1913.  
 Travers, "The Experimental Study of Gases." London, 1901.  
 Anon., "The Use of Liquid Air in Industry," *Engineering*, 99, (1915), 155.  
 Linde, "Separation of the Constituents of Mixtures of Gases by Liquefaction," *J. Soc. Chem. Ind.*, (1911), 744.  
 Garner, "On the Theoretical Efficiency of the Linde Process of Liquefying Air," *J. Franklin Inst.*, 177; (1914), 305.  
 Mewes, "Angaben über Kraftverbrauch und Leistung von Luftverflüssigungs- und Sauerstoff Anlagen," *Z. für Sauerstoff und Stickstoff Industrie*, 5, (1913), 317; "Über die Wirtschaftlichkeit moderner Luftverflüssigungs- und Gastrennungs-Anlagen," *Ibid.*, 5, (1913), 175; "Sauerstofferzeugungs-Anlage System Hildebrandt," *Ibid.*, 2, (1910), 134, 160, 204, 281; 4, (1912), 108.

## SECTION II.—OXYGEN

**Properties of Oxygen.**—Oxygen is a colourless, odourless and tasteless gas, of which the chief physical properties will be found in Table 12, pp. 53–55.

According to Holborn and Austin (*loc. cit.*, p. 58) the mean specific heat varies with temperature as follows :—

Temperature ° C.	$C_p$
20—44°	0·2240
20—63°	0·2300

Its solubility in water is expressed by the following table :—

Temperature °C.	0	10	15	20	40
C.c. of gas (measured at N.T.P.) dissolved by 1 c.c. of water under a pressure of 1 atm., ex- clusive of water vapour.	0·049	0·038	0·034	0·031	0·023

Liquid oxygen is extremely mobile with a faint blue colour, and the density of the vapour agrees with the formula  $O_2$  at  $-182^\circ C$ . The liquid is a non-conductor of electricity, but is strongly magnetic. Its refractive index ( $\mu_D$ ) is 1·2236 and its specific heat 0·347. It is not easy to obtain pure liquid oxygen by the fractionation of liquid air, as the argon tends to accumulate in the oxygen fraction.

Oxygen, being the active constituent of air as regards combustion, supports combustion with great vigour, thus, iron wire will burn freely in oxygen when once started. Oxygen is readily converted into ozone by the action of the silent discharge. Molten silver absorbs some ten times its volume of oxygen, the gas being mostly disengaged on solidification.

## MANUFACTURE OF OXYGEN

**General.**—The manufacture of oxygen has attracted the attention of many inventors and various methods have been suggested. One of the earliest patents is that of White (B.P. 12536/49), relating to the use of nitre. In the early days of the limelight lantern the oxygen was mainly produced by the classical method of heating a mixture of potassium chlorate and manganese dioxide, while the use of manganese dioxide, either alone or with sulphuric acid, was adopted to some extent. In the production of sulphuric anhydride by the contact process a mixture of sulphur dioxide and oxygen was formerly prepared by the decomposition of sulphuric acid by dropping on a red-hot surface (Squire, B.P. 3278/75). The only processes which have been worked on a really large scale are the liquid air process and the baryta process. No real success has attended work directed to the separation of oxygen from the atmosphere by physical means, except, of course, by fractionation of liquid air.

Although at present commercial use is only made of oxygen specifically prepared, it is probable that with the advent of various nitrogen fixation processes, *e.g.* the Haber, Cyanamide, Bucher and other processes, the resulting by-product oxygen will effect a great cheapening of oxygen, not necessarily of a high degree of purity, for many purposes at present out of the question on account of the cost of oxygen.

**(1) Manufacture by the Fractionation of Liquid Air.**—For a description of this method, see Section I.

**(2) By Electrolysis.**—Oxygen is liberated, together with hydrogen, in the electrolysis of water. A full description of this subject will be given under electrolytic hydrogen, Section VI., and all quantitative data can be taken from this description, the yield of oxygen being approximately half that of the hydrogen.

On account of the (past) difficulty of its disposal, the hydrogen produced simultaneously with the oxygen has often been blown to waste or used for heating purposes.



The hydrogen, in conjunction with the oxygen, may, however, be used profitably for welding. If freed from traces of intermixed hydrogen (which may amount to about 3 %) by passage over a heated catalyst, *e.g.* palladized pumice, the oxygen is obtained in an extremely pure state.

On account of its very high purity electrolytic oxygen is eminently suitable for metal cutting operations (*cf.* applications of oxygen). Electrolytic oxygen is manufactured in this country by the British Oxygen Co., Ltd., at Wolverhampton, using the Schuckert cell.

Many attempts have been made by various inventors to produce oxygen without the simultaneous production of hydrogen; such efforts, however, do not appear to have met with any technical success. Thus, Coehn (*cf.* D.R.P. 75930/93) proposes the use of (*a*) cathodes which absorb hydrogen and are subsequently used as elements of a gas cell; *cf.* also Brianchon, F.P. 439737/12, who uses a gas cell of hydrogen and air to generate current for the decomposition of water; (*b*) the use of depolarizing copper oxide cathodes. The use of depolarizing liquids and of electrolytes such as copper sulphate solution, employing insoluble anodes and effecting the deposition of copper, have been similarly proposed.

It is interesting to note that the minimum percentage of hydrogen required to produce an explosive mixture with oxygen is 5.5 %, the influence of increased pressure on the limiting percentage being very small (*cf.* p. 40).

**(3) By Alternate Formation and Decomposition of Higher Oxides, etc.**—Prior to the introduction of the liquid air method about 1895, the only processes (other than electrolytic) which had been used for the production of oxygen on anything like a large scale come under this category. The patents relating to the subject are too numerous to be given in full, but allusion will be made to the more important.

As early as 1864 (B.P.s 2934/64 and 3171/66), Mallet suggested the use of  $\text{Cu}_2\text{OCl}_2$ , formed by exposing cuprous chloride to moist air; on heating to dull redness oxygen is evolved. The alternate formation and decomposition of

alkali manganates was put forward by Tessié du Motay and Maréchal (B.P. 85/66). By heating manganese dioxide mixed with caustic soda to dull redness in a current of air sodium manganate was formed, which on the passage of steam at a bright red heat gave oxygen, the manganate reverting to  $Mn_2O_3$  and caustic soda. Several works were actually erected in Europe and New York, but the life of the reactant mass was found to be rather short, largely on account of segregation. A number of improvements were patented, *e.g.* patents having as object the prevention of segregation, while Parkinson (B.P. 14925/90) employed a vacuum instead of steam, the air being pumped in under pressure and the temperature maintained nearly constant. None of these processes, however, met with any special success.

To take another direction of investigation, the use of alkaline earth plumbates was suggested by Kastner in B.P. 11899/89. Calcium plumbate is formed on calcining a mixture of calcium carbonate and oxide of lead in air and may be decomposed, yielding oxygen, in a variety of ways, *e.g.* by treatment with sodium carbonate solution and subsequent heating of the resulting  $CaCO_3 + PbO_2$  precipitate; by carbon dioxide in suspension in water or by the action of carbon dioxide without removal from the furnace. None of these processes, however, is very practical. According to a modified form of the process a combination of alkali manganate and metaplumbate was used under the name of "Plumboxan" (B.P. 12307/11), the mass being treated alternately with air and steam at a temperature of 400–500° C.

A greater measure of success has attended the use of barium peroxide, the dissociation pressure of which is greater than that of  $Ca_2PbO_4$ . First suggested by Boussingault in 1851, it was developed by Messrs. Brin's Oxygen Co. about 1886 (cf. B.P. 1416/80). It was originally operated using a considerable temperature variation, but by means of pressure variation the time of oxygen evolution was shortened from about 4 hours to about 15 minutes, a considerably lower temperature being sufficient. Further, by means of a suitable arrangement of valves (Brin's Oxygen Co. and Murray,

B.P.s 4955/89, 4292/91 and 14918/93), the operations were rendered automatic, four cycles per hour being adopted, this procedure tending to greater regularity of working and minimizing wear and tear on the retorts. According to B.P. 17298/91 the baryta is disposed on pumice.

The baryta used is obtained in a hard, porous state by ignition of the nitrate; it is important to purify the air from carbon dioxide and from most of its moisture (by lime and then caustic soda) before pumping into the retorts, since both barium carbonate and barium hydroxide are stable at high temperatures. The presence of a little water vapour is necessary since it acts as a catalyst. The vertical steel retorts, containing lumps of about walnut size, are heated to about 600° C. Air at a pressure of about 10 lbs./in.<sup>2</sup> passes through the purifiers and then to the retorts, the residual nitrogen escaping through a snifting valve. After about 7 minutes, connection is made to a vacuum of about 26 ins. of mercury, the first portion of the oxygen being rejected. The rate of production may be expressed as—

(1) About 0.5 ft.<sup>3</sup> oxygen/lb. baryta/hour.

(2) About 25 ft.<sup>3</sup> oxygen/ft.<sup>3</sup> retort capacity/hour.

(Cf. Murray, *Proc. Inst. Mech. Engineers*, (1890), 131.)

The effect of the pressure variation can be readily seen from the following dissociation pressures (Hildebrand, *J. Amer. Chem. Soc.*, **34**, (1912), 246), for barium peroxide in the presence of a little water:—

Temperature °C. ..	618	655	697	737	794	835	853	868
Oxygen pressure in cms. of mercury ..	11.3	26.8	65.4	141	378	718	937	1166
Water vapour pressure in cms. of mercury	7.3	13.7	26.3	47	98	159	195	231

Until recent years the baryta process was used extensively in the works of the Brin's Oxygen Co. (now the British Oxygen Co.), e.g. in 1907 three works were producing 30,000 ft.<sup>3</sup> of oxygen per day; it has now been superseded by the liquid air process not only on account of its lower cost but also because of the greater purity of the liquid air oxygen

(about 98 % as compared with about 95 % by the baryta process).

Other processes on similar lines have been proposed, *e.g.* the use of hæmoglobin (Sinding-Larsen and Storm, B.P.s 8211/10 and 12728/10), the use of nitrosulphonic acid (Bergfeld, B.P. 21211/13), etc., cf. also Teissier & Chaillaux, see p. 206.

(4) **By Auto-combustion Methods.**—The development of such methods of preparing oxygen (cf. also the production of hydrogen from "Hydrogenite," Section VII., p. 227) is mainly due to the French chemist, Jaubert, who in a series of patents (B.P.s 24330/05, 12246/06, and 12262/06) proposes the employment of a mixture of perchlorates or nitrates in excess, with a combustible material, an inert diluent being added, if desired. Special apparatus is described in B.P.s 12834/06, 1256/07, 17252/07, and 22034/09.

Briefly, the apparatus consists of a steel cylinder in which is suspended a perforated cylinder containing the mixture, known as "Oxygenite." The mixture is ignited and the lid rapidly closed when the reaction propagates itself throughout the mass. Oxygen collects in the annular space surrounding the inner cylinder at a pressure of about 12 atms. The yield per lb. of "Oxygenite" is about 4 ft.<sup>3</sup> and the cost about £5/1000 ft.<sup>3</sup>. It is at once obvious that the process is very expensive in comparison with the liquefaction process, but there are advantages for some special cases in the avoidance of transport of cylinders, availability for mine rescue work, etc.

Some slight modifications are due to Harger (B.P.s 16693/10 and 17628/10), the mixture of a chlorate and lamp-black, with addition of a catalyst such as manganese dioxide and also of caustic soda if carbon dioxide be produced in the reaction, being used in the form of pencils; a continuous feed of the pencils may be arranged. The hot oxygen is led back through the unused material and through a purifier.

Other patents relate to alternative mixtures which may be used.

(5) **By the Action of Water on Peroxides and the**

**Like.**—Examination of the patent literature reveals a large number of patents dealing with this method of making oxygen. To take a typical example, sodium peroxide reacts energetically with water according to the following equation:—

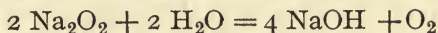

Thus, Jaubert, in B.P. 11466/01, proposes the use of mixtures of alkali or alkaline earth peroxides with alkali or alkaline earth hypochlorites in the form of pastilles, which generate oxygen on treatment with water.

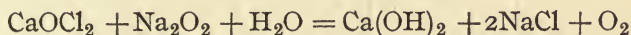

A later patent (B.P. 21122/03) deals with the use of mixtures such as a solution of bleaching powder with the addition of catalysts as copper sulphate and iron sulphate, while Artigue, in B.P. 14848/04, protects apparatus for carrying this process into operation. Hanman, in B.P. 9783/03, describes the mixture known as "Oxylithe,"\* while the use of fused sodium peroxide is suggested by Foersterling and Philipp in B.P. 3820/05. Among the various patents for apparatus may be mentioned that of Ransford (B.P. 9785/02). Other patents, *e.g.* Byk (B.P. 7495/09), describe the use of perborates with the addition of stabilizers and catalysts.

Preparations on the market such as "Oxylithe" are useful for laboratory purposes.

"Oxylithe" may be used in a Kipp's apparatus, one lb. giving about 3 ft.<sup>3</sup> of oxygen while "Epurite" (= bleaching powder + iron sulphate + copper sulphate) is suitable for use on a larger scale, but in either case the oxygen is very expensive.

Experiments have been made with sodium peroxide preparations for revivifying the air of submarines, oxygen being liberated by the moisture of the breath while the resulting caustic soda serves to remove the carbon dioxide.

**(6) By Physical Methods (in the Gaseous State).—**

In view of the fact that the solubilities of oxygen and nitrogen in water at 15° C. are 0.034 and 0.0179 respectively for

* Sodium peroxide	.. 98.32 per cent.
Oxide of iron ..	.. 1.00 per cent.
Copper sulphate	.. 0.68 per cent.

1 atm. pressure, it is obvious that the respective volumes dissolved on shaking water with air are in the ratio  $0.034 \times 1 : 0.0179 \times 4 = 1 : 2.1$ , since the partial pressures of oxygen and nitrogen are 0.1 and 0.4 respectively. Consequently the gas evolved on reducing the pressure or raising the temperature is, if all the gas be driven out, of the composition  $N_2 : O_2 = 2.1 : 1$ , *i.e.* 32 % oxygen, as against the original 21 %. Many attempts to effect an economic separation have been made on these lines ; thus, Mallet (B.P. 2137/69) saturated water with air under pressure and afterwards exposed to a vacuum. After some 8 repetitions the gas evolved was 97 % oxygen. Other patents, *e.g.* Kubierschky (B.P. 17780/99), Humphrey (B.P. 14809/05), Lévy (B.P. 5931/09), are similar.

Although the technical prospects of manufacturing pure oxygen by such processes are small there would appear to be some possibility of making oxygen-enriched air economically, *e.g.* by waterfalls in conjunction with arc processes, etc. The same statement might be made with reference to sundry patents relating to separation by centrifugalization (Mazza, 13598/07) ; by diffusion (Runge, B.P. 3420/14), or by transpiration through indiarubber, etc., (Hélouis, B.P. 2080/81 ; Neave, B.P. 6463/90 ; de Villepique, Fournier and Shenton, B.P. 19044/96 ; Bartelt, B.P. 24428/06).

None of these processes appears to have been applied technically, the liquid air process being apparently the only really successful case of the application of physical methods.

The Linde-Frank-Caro process for the manufacture of hydrogen (cf. p. 172) may be so operated as to yield oxygen and nitrogen as by-products in connection with the cooling of the water gas (the oxygen = about 25 % of the hydrogen produced).

**Compression of Oxygen.**—For a discussion of the precautions to be observed in connection with the compression of oxygen, see p. 34. In this country oxygen is sold under a pressure of 120 atms., in black-painted cylinders, the capacity of which does not usually exceed 100 ft.<sup>3</sup>. It is most important that no oil or grease of any kind should

be allowed to come into contact with the compressed gas, as serious explosions may thus be caused. Steel should not be used in the construction of the cylinder valves since combustion of steel spindles has been known to occur, being started by heat engendered by friction.

### Comparison of Costs of Production and Purity Attainable by Different Processes

It is difficult to give more than a very approximate comparison of the costs of the different processes which have been described in connection with the manufacture of oxygen, but the following table will serve to give some idea of the advances which have been made in this branch of technology. All costs are on a pre-war basis :—

TABLE 21.

COST OF PRODUCTION AND PURITY OF OXYGEN BY DIFFERENT PROCESSES.

Method.	Cost per 1000 ft. <sup>3</sup>	Purity.
From potassium chlorate ..	*£8-10	Liabie to contain traces of chlorine.
From manganese dioxide ..	*£4-6	—
By the Tessié du Motay process	*£3-4	—
By the decomposition of sulphuric acid .. .. .	*£2-3	—
Kassner process .. .. .	*High	—
Brin process .. .. .	*7s. to 12s.	About 95 %.
By solution in water, etc. ..	*£3 ?	—
Oxygenite process .. .. .	£5	—
[Oxylithe.] .. .. .	[£10]	—
Epurite process .. .. .	?	—
By electrolysis .. .. .	† —	Almost perfectly pure if passed over a heated catalyst.
From liquid air .. .. .	*3s. 6d.	About 98 %.

The values of cost marked with an asterisk are taken from Thorpe's "Dictionary of Applied Chemistry," 1912, vol. 4, 40; they are apparently exclusive of overhead charges. In the case of the liquid air process the overhead

† It is difficult to give any cost for electrolytic oxygen, as it depends so much on the price of electric energy and the use to which the hydrogen is put. For any particular case, however, reference to the section on electrolytic hydrogen will supply the desired information.

charges may be taken as of the order of  $1/6$  per 1000 ft.<sup>3</sup> of oxygen.

As regards purity, it is important to note that in the liquid air process about half of the argon initially present in the air (about 0.9 %) goes into the oxygen fraction. The percentage of argon is consequently higher in the oxygen than in the nitrogen. A brief consideration of the respective boiling points of the three gases, viz. nitrogen  $-196^{\circ}$  C., oxygen  $-183^{\circ}$  C., argon  $-186^{\circ}$  C., will indicate the reason for this. "Liquid air" oxygen, therefore, usually contains some 2-3 % of argon. Electrolytic oxygen, on the other hand, can be produced in an almost pure state.

For the influence of purity on the technical applications cf. "Metal cutting," p. 105.

Oxygen manufactured by the liquid air process contains small quantities of organic matter which are liable to introduce errors in organic combustions and similar operations. When one bears in mind the presence of traces of methane and other hydrocarbons in the atmosphere (cf. p. 59), this fact is not surprising; such impurities would tend to be concentrated in the less volatile oxygen fraction.

### Applications of Oxygen

The applications of oxygen are very diverse and it will be well to discuss them under a number of headings as below. Some 150-200 million ft.<sup>3</sup> of oxygen were manufactured in Great Britain in 1913. According to Dewar (*J. Soc. Chem. Ind.*, (1919), 23 R), the present output of the twelve oxygen factories is about 1 million ft.<sup>3</sup>/day.

About 90 % of the above production is absorbed by the welding and metal cutting industries in roughly equal proportions.

(1) **Scientific and Laboratory Uses.**—Oxygen is used in the laboratory for effecting organic combustions, working quartz or hard glass, making ozone and many other specific purposes.

(2) **Therapeutic Uses.**—Oxygen is largely used medically for alleviation in asphyxiation, pulmonary complaints,



etc. ; and by dentists, in admixture with nitrous oxide, for purposes of anæsthesia. It is also used for diving operations, for mine rescue work (cf. also "Applications of liquid air," p. 78), for smoke helmets, and for aeronautical work at high altitudes. Its use has been suggested for improving the atmosphere of theatres, etc., but at present the cost would be rather prohibitive.

(3) **Welding and Cutting of Metals.**—As mentioned above, the principal applications of oxygen are in the welding and cutting of metals, particularly steel.

(a) *Welding.*—The art of autogenous welding is one which has been developed gradually from ancient times. The hydrogen-air, or the much more convenient oxy-coal gas blowpipe, was long used for lead burning, but the industry owes its present standing chiefly to the advent of the oxy-acetylene blowpipe, which came into technical use about 1903. Acetylene has the advantage over hydrogen and coal gas of a considerably higher heat of combustion.

Acetylene, net heat of combustion/ft. <sup>3</sup>	..	815 C.H.U.
Hydrogen,	..	153'3 "
Coal gas,	..	ca. 280 "

Apart from its lower heat of combustion the low pressure of coal gas is a considerable disadvantage. Petrol, benzol, etc., may also be used in conjunction with oxygen.

The equation

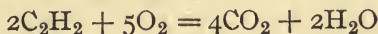

demands  $2\frac{1}{2}$  volumes of oxygen per volume of acetylene, but, in practice, the best results are found to correspond to about 1.0 to 1.5 volumes. This ratio is in accordance with the equation

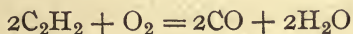

and this represents the reaction in the inner white cone of the oxy-acetylene flame ; the completion of the combustion occurs in the outer cone, this being relatively cool and serving to protect the weld from oxidation. The apex of the cone has a temperature of probably over 3000° C.

There are two systems of working—high and low pressure respectively. The former was the first to be introduced and uses acetylene at about 4-7 lbs./in.<sup>2</sup> pressure from cylinders while the latter is more suitable for acetylene generated directly from calcium carbide. Autogenous welding of steel, aluminium, etc., is employed extensively in connection with the motor industry.

(b) *Cutting*.—In 1889 Fletcher showed that it was possible to cut metals by introducing excess oxygen into the oxy-coal gas flame. Twelve years later Menne, in Germany, applied the process to opening up tuyères which had become blocked; the process was found very convenient and the method gradually became of greater applicability. In the early stages difficulty was experienced from the lack of fluidity of the iron oxide, the cutting being rendered intermittent.

About 1904, however, on the introduction of the cutting blowpipe (by the Soc. Anon. l'Oxydrique Internat. of Belgium), the essential feature of which was the provision of a separate conduit for the "cutting" oxygen, either in the centre of the heating jet or behind it, these difficulties were overcome.

The method of operating is first to heat up a corner of the article to be cut with a normal flame and then to turn on the "cutting" oxygen, when combustion of the iron commences. The fine "cutting" jet has sufficient force to blow away the iron oxide, as it is formed, a thin, regular cut resulting. By means of special guides for the blowpipe it is possible to make a very precise cut.

As in welding, acetylene gives the best results, although operations may be conducted with hydrogen or even with coal gas. The proportions of combustible gas required for the actual cutting are as follows:—

Acetylene ..	25-10	} per 100 volumes of oxygen
Coal gas ..	50-20	
Hydrogen ..	150-80	

according to the thickness of the work.

The purity of the oxygen used is of great importance on

account of the diluent effect of impurities such as nitrogen or argon. For cutting operations a purity of at least 98 % is desirable ; 95 % gives decidedly inferior results, although quite good for welding. According to the International Oxygen Company, the effect of the presence of 9 % nitrogen is to double the time of cutting, while 1 % increases the cost of cutting by about 25 %. It is obvious that the presence of a little hydrogen in electrolytic oxygen is no disadvantage from this point of view.

Some idea of the efficiency of the process may be gathered from the following data (Murray, Thorpe's "Dictionary of Applied Chemistry," 1912), relating to the cutting of nickel-chrome armour plate—

Thickness of armour plate. (in.)	Time per foot cut. (min.)	Oxygen used per foot. (ft. <sup>3</sup> )	Oxygen used per hour. (ft. <sup>3</sup> )
9½	3½	30	530
12	4½	50	650
17	5	112	1350

The advantages of oxygen cutting over mechanical methods are particularly marked in operations of demolition of steel structures, *e.g.* bridges and the like.

(4) **Other Applications of Oxygen.**—Among other applications of oxygen may be mentioned the following :—

The use of pure oxygen has been proposed (Pictet, F.P. 475528/14) in the manufacture of water gas. By passing a mixture of steam and oxygen into the centre of the charge, it is possible to obtain continuous operation as opposed to the usual intermittent procedure. The employment of oxygen for opening refractory tap-holes and blocked tuyères, has already been mentioned. Experiments have been made on the operation of Bessemer converters with pure oxygen, while the introduction of oxygen into fluid glass is found beneficial.

Oxygen is also used, mostly on a small scale, for increasing the temperature of furnaces (*cf.* also "Oxygen-enriched air").

Oxygen is used for the fusion of platinum ingots (usually in conjunction with hydrogen), and also for the fusion and manipulation of transparent quartz glass. The use of oxygen for producing high power lights, *e.g.* in admixture with oil gas or coal gas, with or without mantles, has been tried but has not proved a commercial success. Similarly, proposals have been put forward for the addition of oxygen to increase the working pressures of internal combustion engines.

There are many patents, *e.g.* Farbwerke, vorm. Meister Lucius and Brüning (B.P.s 15948/11 and 13842/13), dealing with the use of oxygen in connection with the conversion of oxides of nitrogen (particularly in the liquid form) into concentrated nitric acid. According to their D.R.P. 249329, compressed oxygen is employed. The use of oxygen in bleaching is said to give good results, effecting a saving in bleaching powder. Milk can be sterilized by exposure in the fresh condition to some 5 atmospheres pressure of oxygen for several hours. Similarly, oxygen is used in the manufacture of oxidized oils, having the advantage that the process can be effected at a steam heat, and that no "driers" are required; also for the artificial maturing of spirits, in the production of vinegar, etc. It is claimed (Valon) that by the addition of oxygen (about 0.1 %) instead of air, the elimination of sulphuretted hydrogen from coal gas by the usual iron oxide purifiers is greatly facilitated. Dilution with nitrogen is avoided (which is important when the gas is used as an illuminant with ordinary batswing burners), and the capacity of the ore for taking up sulphur is increased to 75 % of its weight of sulphur instead of 50 %.

The Vickers process of case-hardening steel consists in effecting a sudden local heating of the surface of the steel by means of an oxy-acetylene flame, on the removal of which the heated layer is quenched by the body of cold metal underneath.

**Oxygen-enriched Air.**—There are a number of applications of oxygen to technical processes in which even approximate purity of the oxygen is a matter of small importance

or possibly undesirable ; it will be preferable to deal with such applications under the heading of oxygen-enriched air. It is probable that with the further cheapening of oxygen, many new industrial applications of this character will present themselves. Among such uses may be mentioned the following :—

(1) *Use of oxygen-enriched air in the blast furnace.*—Trials have been carried out by Trasenster at Ougrée-Marihaye, Belgium (*Engineering*, (1913), 374), with a blast furnace supplied with air of 23 % oxygen content instead of the normal 21 %. As a result, a diminution of 5 % in the coke consumption and an increase of 10–15 % in the output were experienced, the cast iron being of excellent quality and rich in silicon.

The oxygen was supplied by three Claude plants, each of capacity 70,000 ft.<sup>3</sup> oxygen/hr. Johnson (*Metall. and Chem. Eng.*, 13, (1915), 483) found that an increase of the oxygen content to 50 % resulted in a fuel economy of 33 % when using a cold blast as against the normal dry hot blast. The economy is still greater in the manufacture of ferro-silicon, where a higher temperature is required.

(2) *The use of oxygen-enriched air in the arc process for nitrogen fixation.*—It has been found that by raising the oxygen content to 50 % the yield of nitric acid in the above process can be increased from 500 kilos./K.W.Yr. to 625 kilos./K.W.Yr., the cost of the oxygen being more than balanced by the increased production. Some workers have found as much as 50 % increase in efficiency. It is necessary to work with a closed cycle, as only about 3 % conversion takes place under the most favourable circumstances.

(3) *The use of oxygen-enriched air in the Häusser process.*—This process depends on the production of oxides of nitrogen by the explosion of a compressed mixture of air and a fuel gas. By increasing the oxygen content of the air to about 26 % the yield of oxides of nitrogen is raised from 6.4 lbs. to 10 lbs. per 1000 ft.<sup>3</sup> of the combustible gas. According to these experiments (at Wendel in Germany) it was expected, with a supply of 7350 ft.<sup>3</sup>/hr. of coke gas, to make about 1 ton

of nitric acid per diem, by the addition of about 2500 ft.<sup>3</sup> oxygen per hour. See also this series Partington, "The Alkali Industry," p. 174 *et seq.*

(4) *Other applications of oxygen-enriched air.*—The use of oxygen-enriched air has also been proposed in the oxidation of ammonia to nitric acid by the Ostwald process; in the oxidation and absorption of the oxides of nitrogen resulting from this and other operations, and in the manufacture of sulphur trioxide by the contact process.

**Estimation and Testing of Oxygen.**—Oxygen is readily recognized when present even in small quantities in other gases. If present in hydrogen its estimation is perhaps best effected by means of the so-called "Grisometer" by the action of a red-hot platinum wire. The contraction is equal to three times the volume of the oxygen present. For an automatic oxygen detector on this principle cf. Greenwood and Zealley, *loc. cit.* When the oxygen is present in a non-combustible gas, or where, for various reasons, the use of a Grisometer is undesirable, the oxygen is readily determined by absorption by copper gauze in the presence of ammonium hydroxide and ammonium carbonate, by pyrogallol, by sticks of phosphorus, or by sodium hydrosulphite.

The copper gauze method is very convenient, an absorption pipette taking up large quantities of oxygen without agitation; after the absorption the gas is freed from ammonia before measurement. If present in the gas, carbon monoxide is also absorbed by this reagent. When using phosphorus the temperature must not be below 15° C. or oxidation does not occur readily; the presence of certain gases has a similar inhibitive effect. The use of pyrogallol also has some disadvantages as, under certain conditions, carbon monoxide is evolved by the reagent.

Sodium hydrosulphite—used in weakly alkaline solution—is an energetic absorbent for oxygen and is free from the drawbacks of the other absorbents mentioned; it does not absorb carbon monoxide. When present in small quantities, oxygen may be estimated colorimetrically by the red coloration produced in a solution of pyrogallol or a mixture of

pyro-catechine, ferrous sulphate and alkali in aqueous solution (Binder and Weinland, *Ber.*, (1913), 255).

The purity of commercial oxygen is best determined by absorption with one of the above mentioned absorbents, e.g. sodium hydrosulphite, and measurement of the small residue. Small quantities of carbon dioxide are readily determined by absorption with caustic soda, while hydrogen may be estimated by the Grisoumeter method.

#### REFERENCES TO SECTION II.

Engelhardt, "The Electrolysis of Water" (Richards). Easton, Pa., 1904.

Murray, "On the Mechanical Appliances Employed in the Manufacture and Storage of Oxygen (Baryta Process)," *Proc. Inst. Mech. Eng.*, (1890), 131.

Richardson, "Autogenous Welding." London, 1913.

### SECTION III.—NITROGEN

**Properties of Nitrogen.**—Nitrogen is a colourless, odourless and tasteless gas, the most important physical properties of which will be found in Table 12, pp. 53-5. The solubility in water is given in the following table:—

Temperature °C.	0	10	15	20	40
C.c. of gas (measured at N.T.P.) dissolved by 1 c.c. of water under a pressure of 1 atm. exclusive of water vapour.	0·0239	0·0196	0·0179	0·0164	0·0118

The variation of the mean specific heat with temperature has been found by Holborn and Henning (*Annalen*, (4), **18**, (1905), 7139; **23**, (1907), 809) to follow the expression  $C_p = 0·2350 + 0·000019t$  between 0° and 1400° C. According to Crofts (*Chem. Soc. Trans.*, (1915), 290),  $C_v = 0·1677 + 0·000014t$ , where  $C_v$  is the mean specific heat between  $t$  and 15·5° C.

Liquid nitrogen is very mobile and quite colourless, with a refractive index ( $\mu_v$ ) of 1·2053 at the boiling point. Its specific heat is 0·43. For other properties see Tables 12 (B) and 12 (C).

Nitrogen is generally regarded as a very inactive element. To a very considerable extent, by comparison with such gases as oxygen, this is true, since very few, if any, reactions are known in which nitrogen enters into combination at the ordinary temperature. Given, however, the stimulus of high temperatures or of catalysts, nitrogen is capable of forming directly a great number of compounds. Thus, the endothermic compound nitric oxide can be produced by heating air to very high temperatures, and then rapidly chilling,



while the exothermic compound ammonia is easily formed at a moderate temperature in the presence of a suitable catalyst, especially at increased pressures. Nitrides are formed by direct combination with a large number of metals and non-metals at high temperatures.

According to recent experiments of Strutt, nitrogen can be obtained in an allotropic form known as "active nitrogen," by the passage of an electric discharge, preferably with a condenser and spark gap in parallel, through nitrogen at a pressure of a few mm. of mercury. A yellow glow is set up in the gas and persists for a period varying from several seconds to some minutes according to the conditions; the rate of disappearance of the glow rises with increase of pressure. While in this state, the nitrogen has the property of combining in the cold with various substances, *e.g.* with acetylene to form hydrocyanic acid, or with liquid mercury to form mercury nitride. No combination with oxygen or hydrogen has been observed up to the present. It is found that perfectly pure nitrogen does not give the glow, but its formation is induced by the presence of minute amounts of various impurities, *e.g.* 0.013 % oxygen, 0.001 % methane, traces of sulphuretted hydrogen, ethylene, etc.

For further information on this interesting subject, cf. Strutt, *Chem. Soc. Trans.*, (1918), 200, and previous papers, also Lowry, *Trans. Faraday Soc.*, 9, (1913), 189.

#### MANUFACTURE OF NITROGEN

**General.**—The production of nitrogen is a subject of great and increasing importance at the present time, chiefly in connection with the various synthetic processes for the fixation of atmospheric nitrogen. In describing this subject it will be unnecessary to make more than a passing allusion to such methods as depend on a direct separation of the constituents of the atmosphere, either by chemical or physical means, since obviously all that has been said with reference to such methods under oxygen, applies also to the case of nitrogen; moreover, no extensive use appears to have

been made of such methods, with the notable exception of the liquid air process.

(1) **By the Fractionation of Liquid Air.**—The manufacture of nitrogen by this method, which is the only process worthy of consideration at the present time, if approximately pure nitrogen be required in large quantities, has already been fully described (pp. 81 *et seq.*).

(2) **By Direct Chemical Removal of the Oxygen from Air.**—The processes coming under this heading may be divided into two classes: (*a*) those depending on the alternate absorption and disengagement of oxygen; (*b*) those involving the absorption of oxygen with the formation of an oxidized compound which may be regenerated subsequently without the production of free oxygen.

(*a*) Practically all that has been said under "Manufacture of Oxygen," Section II., applies equally to nitrogen. The Brin process was the most important, but the nitrogen (cf. Price, B.P. 14213/03) does not appear ever to have been collected and purified technically.

(*b*) The only process which has had any important industrial application is that depending on the use of metallic copper, but as many interesting reactions are involved a few of the numerous patents may be mentioned here.

We find reference to the preparation of nitrogen by passing air over heated iron sponge as early as 1869 (Spencer, B.P. 3752/69). The use of copper turnings was proposed by *e.g.* Welton, B.P. 2559/79. Franke and Finke (B.P. 10718/12) used copper gauze, which was subsequently reduced by methyl alcohol or water gas. According to the Cyanidgesellschaft (D.R.P. 218671/12), two concentric retorts are employed for this purpose, the charge of one undergoing oxidation, while that of the other is being reduced, heat-interchange thus being effected.

On similar lines is the process of the New York Nitrogen Co. (B.P. 17666/11) for removing the oxygen by means of molten lead. The use of sulphur (Blagburn, B.P. 25535/08) or phosphorus (Haddan, B.P. 24293/95) has also been suggested. Other inventors have protected the use of wet

methods, *e.g.* Wise (B.P. 4359/77) passes air over iron filings moistened with ferrous sulphate solution, and Alder (B.P. 1004/80) uses moist barium sulphide, etc. Similarly Knecht, Perl and Spence in B.P.s 25532/11 and 25533/11, make nitrogen in the course of dissolving cellulose in aqueous ammonia and cupric hydroxide, while Elektrizitätswerk Lonza, A. G. (D.R.P. 302671/16) passes air through a hot solution of ammonium sulphite.

The "Harcourt" method of passing a mixture of air and ammonia over heated copper turnings forms an excellent means of preparing nitrogen on a semi-technical scale (*cf.* Hutton and Petaval (*J. Soc. Chem. Ind.*, (1904), 87; Marston, B.P. 19074/1900). It is important to use a considerable excess of ammonia (about twice the theoretical quantity), as otherwise, oxides of nitrogen are formed. After removal of ammonia, the nitrogen contains about 4% of hydrogen, which can be easily eliminated by copper oxide, if necessary. Nitrogen, prepared in this manner, costs about 17/- per 1000 ft.<sup>3</sup>.

In a series of patents by the Farbwerke vorm. Meister, Lucius u. Brüning, the manufacture of nitrogen in the oxidation of ammonia is proposed; excess of air is avoided, nitrogen being obtained after separation of the oxides of nitrogen. If desired, nitrogen may be added to keep down the temperature (B.P.s 3662/13, 28737/13, and 9974/14).

Of these methods, the "copper" process appears to be the only one which has had any measure of technical success. Vertical cast-iron retorts are usually employed to contain the copper turnings or sponge; the retorts are heated to redness in an ordinary furnace setting and are fed alternately with air and water gas or other reducing medium. Thus, part of the plant of the American Cyanamide Co. is supplied with nitrogen by this process, the reduction being effected by the gas from the coke-oven plant installed in connection with the carbide production (*cf.* "Applications of Nitrogen"). According to Bucher (*J. Ind. and Eng. Chem.*, 9, 1917, 233), a temperature of 450° C. suffices for the efficient conduct of the operation, and a volume of about 3.3 ft.<sup>3</sup> in the retort

containing the copper turnings, gave an output during the oxidation phase of some 200 ft.<sup>3</sup> per hour. It was found important to guard against the tendency of the copper turnings to cement together and block the gas passage, by the provision of adequate support among the turnings.

Nitrogen results, in a more or less pure state, as a by-product from a number of chemical processes, *e.g.* the effluent from the chamber sulphuric acid process, in the Brin process, in the manufacture of sodium carbonate by the ammonia soda process (cf. p. 269), and also in the manufacture of wood pulp by the sulphite process.

The nitrogen present in products of combustion is dealt with in the next section.

### (3) From Producer Gas and Products of Combustion.

—Since air consists of 79 % nitrogen, it is evident that in the combustion of carbonaceous matter, the reaction products, after separation of the water, will consist in large proportion of nitrogen mixed with carbon dioxide, which gas is very easily removed, or with carbon monoxide if the combustion be only partial as in air producer gas. It will be convenient to deal separately with the nitrogen in the two cases.

(a) *Producer Gas*.—Air producer gas contains some 30 % carbon monoxide, the remainder being mainly nitrogen with a little hydrogen, methane, etc. A description will be found under “Manufacture of Hydrogen” (p. 205) of the production of hydrogen or mixtures of hydrogen and nitrogen from producer gas through the intermediary of formates.

(b) *Products of Combustion*.—In this case we have a somewhat simpler proposition, the gas from which the nitrogen is to be isolated consisting of nitrogen, aqueous vapour, carbon dioxide, with probably carbon monoxide or oxygen or both and perhaps small amounts of sulphur compounds. The removal of the carbon monoxide and/or oxygen, has attracted the attention of a number of inventors, thus Lance and Elworthy (B.P. 4409/06) complete the oxidation by passage over heated copper oxide; the use of a heated mixture of a metallic oxide and the corresponding metal, *e.g.* copper

oxide and copper, is claimed by Frank and Caro (B.P. 16963/08), serving the purpose of removing carbon monoxide and oxygen, either alone or separately. According to Riedel (B.P. 20631/09), a small proportion of reducing gas is added to the products of combustion, the better to preserve the balance. The Braun process, founded on the above patent (cf. B.P. 22531/11), is used on the large scale in Berlin. The Kitzinger process, which is very similar, is stated to be used especially for cyanamide production (cf. *Chem. Trade J.*, 62, (1918), 88). After some purification, the furnace gases containing a certain excess of oxygen, are passed with producer gas into a heated retort where the oxygen is removed. The carbon dioxide is absorbed by passing the cooled gases up towers fed with potash solution, the potash being regenerated by heating the solution (cf. p. 264). Success is stated to depend on an outlet for the large quantity of carbon dioxide simultaneously produced. Harger (B.P.s 28075/11 and 16855/12) advocates the use of a gas engine exhaust in order to secure a regular combustion, passing the gases over a catalyst, *e.g.* titaniferous bog iron ore, with or without use of the copper-copper oxide mixture, which may be employed at 100–200° C. under a pressure of about 5 atmospheres. The carbon dioxide is removed according to various known methods. Other inventors make use of surface combustion to facilitate exact proportioning of the fuel and air, *e.g.* McCourt and Ellis (B.P. 25629/12), while Dreaper (B.P. 12927/13) adopts similar methods, but utilizes the heat in the cyanamide or cyanide retorts for which the nitrogen is being manufactured, cf. also Brownlee and Uhlinger (B.P. 5097/15).

All the above processes are designed to produce, in the first instance, a mixture of nitrogen and carbon dioxide, the latter component being separated in a variety of ways. For a detailed discussion of the removal of carbon dioxide and other impurities, cf. p. 117; also for the isolation of the same, cf. p. 264.

(4) **By Physical Methods (in the Gaseous State).**—The eminently successful application of physical methods to

the separation of the constituents of air by the liquid air process, has been described. For a discussion of other physical methods, cf. "Manufacture of Oxygen" (p. 94). It may be mentioned that in the production of hydrogen by the Linde-Frank-Caro process, the cooling of the water gas to  $-200^{\circ}$  C. entails the production of large quantities of more or less pure nitrogen, about equal in volume to the hydrogen produced.

(5) **By Direct Chemical Methods.**—It should be pointed out that all the processes thus far described give, not pure nitrogen, but a product containing a certain proportion of argon as well as traces of the other rare gases. For example, nitrogen prepared by the liquid air process may contain up to about 0.5 % of argon; that by the majority of other methods, about 1.2 %. There are few, if any, industrial applications in which absolute freedom from argon is essential.\* It is, however, of interest to indicate briefly, possible methods of securing argon-free nitrogen on a fairly large scale. Such nitrogen is easily obtained from a large number of reactions, *e.g.* from solutions of ammoniacal salts, by passing ammonia over heated copper oxide, by the action of sulphur on cyanamide (Naef, B.P. 14607/12), etc.

### Purification of Nitrogen

Allusion has been made in the preceding pages to the elimination of specific impurities from nitrogen. It will, however, be of advantage to collect together methods of dealing with the different impurities likely to occur in commercial nitrogen, either in large or small concentrations.

**Purification from Carbon Monoxide.**—Although many of the processes detailed under the Purification of hydrogen, are equally applicable to the case of nitrogen, it is obviously much cheaper to effect the desired operation by heated

\* Argon content is of considerable importance in such cases as the synthesis of ammonia where the reactants, nitrogen and hydrogen, are circulated continuously over a catalyst in a closed system. Any argon present rapidly accumulates and lowers the output of the plant, *ceteris paribus*, in proportion to its concentration and necessitates blowing off the gases to waste. Similar considerations apply in cyanamide production.

copper oxide (cf. p. 114), and subsequent removal of the carbon dioxide produced.

**Purification from Carbon Dioxide.**—A full account of the different methods of removing carbon dioxide in large or small quantities from hydrogen, will be found on p. 209 (cf. also p. 161). All these methods, of course, apply equally to nitrogen.

**Purification from Oxygen.**—The removal of small quantities of oxygen is effected conveniently with heated metallic copper, etc. (cf. p. 113), or, if the presence of a little reducing gas is not detrimental, by the addition of a slight excess of hydrogen or other reducing gas, and passage over a heated catalyst, *e.g.* platinized pumice, etc.

**Purification from Sulphur Compounds.**—In this connection, reference may be made to the information given on p. 210, relating to the purification of hydrogen. All these methods are applicable to nitrogen, with the exception of the Carpenter catalytic hydrogenation method.

### Comparison of Costs of Production and Purity attainable by the Different Processes

Nitrogen can be manufactured on a large scale, say 10,000–20,000 ft.<sup>3</sup>/hr., at a cost (pre-war) not greatly exceeding  $\frac{1}{6}$  per 1000 ft.<sup>3</sup> inclusive of capital charges. On a smaller scale the cost of production will be higher, say  $\frac{1}{4}$  per 1000 ft.<sup>3</sup>. The copper process is more expensive.

As regards purity, reference has been made to the argon content on p. 116. Liquid air nitrogen usually contains some 0.5 % oxygen and up to about 0.5 % argon.

### Applications of Nitrogen—Nitrogen Fixation

The only important industrial consumption of nitrogen is in connection with the fixation of free nitrogen. It is scarcely possible to exaggerate the importance of this relatively new branch of chemical technology. The manufacture of explosives without the use of Chile saltpetre, has occupied the attention of belligerent countries during the war, and the war would have been impossible in Germany but for the

recent advances in the synthetic production of ammonia and nitric acid: the manufacture of artificial fertilizers in peace time, is of almost equal, if less sensational, national importance.

A brief description will be given of the chief processes involving the use of free nitrogen. The arc process, which depends on the combination of the constituents of the atmosphere under the influence of a high-tension arc, does not necessitate any preliminary separation of the nitrogen and oxygen.

Nitrogen is sold in this country in grey painted cylinders, under a pressure of 120 atms.; there is, as yet, no great demand for nitrogen in this form.

(a) **Cyanamide Process.**—The inception of this important process is due to the researches of Frank and Caro, about 1895. It depends on the direct absorption of free nitrogen by calcium carbide when heated to 1000–1100° C. Reaction does not occur under these conditions with the pure carbide, but proceeds readily with the commercial product.

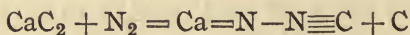

This compound, known as cyanamide or “nitrolim,” is stable in dry air and is valuable as a fertilizer; as a source of ammonia, which is easily produced by hydrolysis with steam under pressure; in the production of cyanides, and in the production of various dye-stuffs; in the manufacture of urea; in explosives; case-hardening media, etc.

The usual method of effecting the reaction is to raise the temperature of a relatively small charge of powdered calcium carbide, contained in a lagged closed vessel, to a high temperature by means of an electrically-heated carbon rod, and to supply nitrogen, whereupon the exothermic reaction propagates itself slowly through the mass, the entire operation occupying some 30–40 hours. It is important that the nitrogen should be free from water and oxygen, which would react with the carbide and cyanamide respectively. The product usually contains some 20% nitrogen; pure  $\text{CaCN}_2$  contains 35% nitrogen. A little calcium carbide



(about 1 %) is usually left unchanged in the product, and, to make transport safe, is removed by partial hydration; for agricultural purposes, the powder is oiled to minimize its dusty propensities. One of the chief drawbacks to the use of the cyanamide process in this country, is the high power consumption as compared with the Haber and Cyanide processes (cf. p. 121). With cheap water power, on the other hand, the conditions are more favourable. The first plant was erected at Piano d'Orte in 1905; there are many plants in Norway (particularly at Odda), at Niagara, in Switzerland, Germany, etc.

Some 200,000 tons of cyanamide were produced in 1914; in 1917, the production in Germany alone is stated to have been 886,000 tons ( $= 5400 \times 10^6$  ft.<sup>3</sup> nitrogen), while similar extensions have taken place in other countries; according to Marselli, the world production in 1916 was 981,500 tons (*Chem. Trade J.*, 63, (1918), 182).

The nitrogen for cyanamide production was at first made by the copper process, but is now mostly produced by the cheaper liquid air process; the American Cyanamide Co., however, operates part of its plant by the copper process, the reduction of the oxide being effected by the coke oven gases from the coke plant in connection with the carbide manufacture (cf. p. 113).

The cyanamide plant in contemplation by the American Air Nitrates Corporation during the war, was to produce 350,000 tons of cyanamide per annum, a power plant of 60,000 K.W. being necessary.

(b) **The Synthesis of Ammonia.**—An account of this process will be given under the applications of hydrogen. The probable consumption of nitrogen for this purpose in Germany at the end of the war was of the order of at least 3000 million ft.<sup>3</sup> per annum or about 350,000 ft.<sup>3</sup>/hr. Reference has already been made (p. 116) to the influence of the argon content in this application of nitrogen.

(c) **The Formation of Metallic Nitrides.**—There are a number of processes for the production of different nitrides by direct combination of nitrogen. Chief of these is the

Serpek process, which depends on the action of nitrogen on a mixture of bauxite (impure alumina) and carbon at a temperature of about 1800° C.

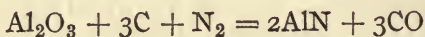

Most of the silica of the bauxite is volatilized. The process is carried out in rotary furnaces, electric resistance heating being employed; it is apparently not necessary to use pure nitrogen, air producer gas, which contains about 60 % nitrogen, being adequate. With bauxite, a product containing 20–26 % nitrogen is obtained, while pure alumina gives the pure nitride containing 34 %. The process is best used in conjunction with the production from bauxite of pure alumina for the manufacture of aluminium by electrolysis. Thus, the nitride on decomposition with alkalis yields ammonia and sodium aluminate if caustic soda be employed; by precipitation of alumina from the latter, a very pure product is secured.

Large scale operations are being carried out in Savoy by the Société Générale des Nitrures. A Claude nitrogen plant, with a capacity of about 10,000 ft.<sup>3</sup>/hr., was recently put down for this purpose. There are a number of patents, many by the Badische Anilin & Soda Fabrik, dealing with the addition of other nitride-forming substances to the alumina and also with the use of other nitrides in the place of aluminium nitride.

(d) **The Direct Production of Cyanides.**—There have been many proposals for the fixation of nitrogen by the production of cyanides; thus, if barium carbonate mixed with carbon be treated with nitrogen at a temperature of about 1400° C., barium cyanide results and on treatment with steam gives barium hydroxide and ammonia. The only process, however, which has offered any real prospect of being worked on a large scale is that due to Bucher (*loc. cit.*, p. 113), which has recently attracted considerable attention in the United States. It depends on the action of a mixture of sodium carbonate, carbon and a small quantity of iron, which acts as a catalyst, on air producer

gas at a temperature of about 920° C., with the production of sodium cyanide.

The product can be converted into ammonia if desired, with regeneration of the sodium carbonate and iron.

This process holds out promise of great advantage over most of the other nitrogen fixation processes, on account of its crudity ; no electric power is required and pure nitrogen is unnecessary. On the other hand, the necessity of external heating of retorts to the requisite high temperature, combined with the corrosive properties of the reactants at high temperatures, makes transition from a semi-technical scale to large scale working difficult.

(e) **The Häusser Process.**—This process depends on the production of oxides of nitrogen on the explosion of compressed fuel gas-air mixtures (cf. p. 107).

**Comparison of the Power Requirements in various Nitrogen Fixation Processes.**—Before leaving the consideration of this very important subject, it will be interesting to give some approximate figures for the relative power requirements of the different processes described above, in terms of 96 % nitric acid as ultimate product. Where ammonia is the immediate product, nitric acid is obtained by oxidation according to the Ostwald or allied processes.

	Arc process.	Cyanamide process.	Haber process.	Serpek process.
Power required per ton 96 % nitric acid. K.W. years	1·80	0·38	0·050	0·2

Cf. Parsons, *J. Ind. Eng. Chem.*, (1917), 829.

As regards the costs of production, the following may be taken as an indication of the relative values of the processes. (Norton.)

Cost per ton of 100 % nitric acid—

- (a) from Chile nitrate at 1914 rates .. .. £20  
 (b) by the Arc process with power at 0·0685*d.*/K.W.H. £12  
 (c) by the Cyanamide process .. .. £12  
 (d) by the Haber process .. .. £7

**Other Applications.**— Considerable quantities of nitrogen, small in comparison with the amounts used in connection with the above processes, are utilized in the filling of "half-watt" electric lamps, although nitrogen is rapidly being replaced by the more effective argon. The advantage of a certain amount of gas (about  $\frac{1}{3}$  atm.) in the bulb is that the filament can be run at a temperature 400–600° C. higher, with consequent marked increased efficiency, without producing "blackening" of the bulb.

Nitrogen is used for the storage and transfer from one vessel to another of highly inflammable liquids like petrol.

High temperature mercury thermometers are filled with compressed nitrogen.

### Estimation and Testing of Nitrogen

In view of its inertness towards reagents at the ordinary temperature, nitrogen is usually estimated by difference, *i.e.* by determination of the residue after removal of other gases. Oxygen, carbon dioxide and carbon monoxide are readily estimated separately by the methods described under the individual gases. In admixture with hydrogen or other combustible gas, nitrogen is usually estimated by passing the gas over copper oxide when hydrogen, say, is removed and a residue of nitrogen remains. Mixtures with hydrogen lend themselves well to physical methods of analysis. Occasionally it is necessary actually to absorb nitrogen in order to determine the content of rare gases; in such cases, the absorption is best effected by metallic calcium (cf. Sieverts, *Z. Elektrochem.*, **22**, (1916), 15) or by calcium carbide.

### REFERENCES TO SECTION III

- General.**—Crossley, "The Utilization of Atmospheric Nitrogen," *Pharm. J.*, (1910), 329.
- Nitrogen Fixation in General.**—Norton, "Utilization of Atmospheric Nitrogen," Dept. of Commerce and Labour, U.S.A., Special Agents Series, No. 52.
- Summers, "Fixation of Atmospheric Nitrogen," *Proc. Amer. Inst. Elec. Eng.*, (1915), 337.
- Cyanamide Production.**—Landis, "The Fixation of Atmospheric Nitrogen," *Met. and Chem. Eng.*, **13**, (1915), 213.
- Washburn, **13**, (1915), 309.

## SECTION IV.—THE RARE GASES OF THE ATMOSPHERE

**General.**—The discovery of argon by the brilliant work of Ramsay and Rayleigh, has led to the rapid development of our knowledge of these minor constituents of the atmosphere. Recently there have arisen certain applications which confer on them the right to be termed “industrial” gases. It is interesting to recapitulate the approximate volume percentages present in the atmosphere.

Argon	..	..	0·93236 %
Neon	..	..	0·00181 %
Helium	..	..	0·00054 %
Krypton	..	..	0·0000049 %
Xenon	..	..	0·00000059 %
Nitron	..	..	} very minute amounts.
Thorium emanation			

**History of the Discovery of the Rare Gases.**—In 1892, certain discrepancies were noticed by Rayleigh between “chemical” nitrogen and nitrogen produced by removal of oxygen from the atmosphere, the former being some 0·5 % lighter than the latter.

Two years later Ramsay carried out experiments on the treatment of air, after removal of oxygen, with heated magnesium which absorbs the nitrogen. A reduction to 1/80th of the original volume was effected, and the density increased to 16·1 ( $O_2 = 16$ ); by further treatment the density rose to 19·038. It was at first thought that the new gas, which resisted the action of magnesium, bore the same relation to nitrogen as ozone does to oxygen, but by gradual accumulation of evidence, it was established that a new element had been isolated.

At this point, Ramsay and Rayleigh carried out experiments on a larger scale, with the method originally used by Cavendish, viz. of removing nitrogen by combination with the oxygen of the air under the influence of an electric discharge. A high-tension arc was run (using about 800 watts), in a 50-litre flask of which the inner surface was washed by a continuous fountain of caustic soda solution, the flask being supplied with a mixture of air and oxygen. Absorption took place at the rate of about 20 litres per hour. The process, if desired, can be pushed to completion, but the final concentration is better effected by other methods. The above investigators also employed the method of passing atmospheric nitrogen over a mixture of metallic magnesium and quicklime (originally used by Maquenne, *Comptes Rend.*, 121, (1895), 114), heated to bright redness.

In 1889, it was found by Hillebrand that a certain mineral, Clèveite, on heating evolved a gas resembling nitrogen. Hearing of this, it occurred to Ramsay that the gas might be argon. On carrying out experiments, however, the gas was found to be not argon, but a new gas, which was subsequently (1894) termed "helium." Further researches on the fractionation of liquid air, which was just becoming available on a fairly large scale (cf. p. 69), led to the isolation of neon, krypton and xenon.

### ARGON

**Occurrence.**—Argon is present to the extent of 0.93 % in the atmosphere; it occurs in mineral springs (*e.g.* the gases from the Wildbad hot springs contain 1.56 % argon and 0.71 % helium), in meteorites, and in a few rare minerals such as malacone ( $3(\text{ZrO}_2 \cdot \text{SiO}_2) \cdot \text{H}_2\text{O}$ ).

**Manufacture.**—Reference has already been made to the preparation of argon by the action of magnesium mixed with quicklime on atmospheric nitrogen—it is important that the lime used should be free from hydrate and carbonate, as otherwise serious explosions may result. Metallic calcium can also be used with good effect.

A method which appears to be more suited than most

for technical operations on a moderate scale, depends on the absorption of nitrogen by calcium carbide. According to Fischer and Ringe (*Ber.*, **41**, (1908), 2017), cf. also, Fischer and Hähnel, *ib.*, **43**, (1910), 1435, air was passed into an iron retort heated to about 800° C. and containing calcium carbide mixed with about 10 % calcium chloride which facilitates the absorption at this comparatively low temperature (cf. the "Manufacture of Cyanamide," p. 118). The nitrogen is absorbed with the formation of cyanamide while the oxygen is partly fixed as carbonate, some carbon monoxide being also formed. The retort was first exhausted, then heated up and air admitted until no further absorption was observed; the contents of the retort were then circulated in the sequence—copper oxide—caustic potash—sulphuric acid—phosphorus pentoxide—pump—gas-holder—retort—until absorption was complete. Some 11 litres of fairly pure argon were thus made in two days with a charge of 7 kilos. of calcium carbide. The chief drawback to the process is the fact that the residue of carbide + cyanamide is very difficult to remove from the retort.

It is obvious that in the manufacture of cyanamide on the large scale, large quantities of argon must be produced in a concentrated state, particularly if the nitrogen be prepared by the copper process, and many thousands of cubic feet of highly concentrated argon are sold annually by the American Cyanamide Co., for lamp-filling purposes (cf. Washburn, *Chem. News*, **112**, (1915), 29). For similar procedure in the fixation of atmospheric nitrogen as cyanide, cf. Bucher, B.P. 4667/13.

Residues from the synthetic production of ammonia, and from direct nitric acid manufacture using oxygen-enriched air, with closed circulatory systems, are also possible sources of argon. For the latter instance cf. Norsk Hydro Elektrisk Kvälstofaktieselskab, B.P. 100099/16, according to which the circulation is so conducted that the percentage of rare gases is maintained at about 10 %.

A convenient method of making argon in the laboratory depends on the high argon content of commercial "liquid

air" oxygen, which often contains some 2-3 % argon and but little nitrogen. For example, Claude (*Comptes Rend.*, **151**, (1910), 752) describes apparatus for the preparation of argon at a rate of about 5 litres/hr. from 96 % oxygen, passing the same over heated copper and through an iron tube containing magnesium and heated to redness.

On similar lines is the patent (F.P. 473985/14) of the Griesheim-Elektron Co., according to which oxygen as above is burnt with the correct proportion of hydrogen either with a flame in a water-cooled vessel, or in the presence of a catalyst, *e.g.* copper. A detailed description of a method based on this process, is given by Bodenstein and Wachenheim (*Ber.*, **51**, (1918), 265). "Liquid air" oxygen is burnt with hydrogen in a small quartz combustion chamber. After cooling to remove steam, the exit gases are led through a sensitive rate gauge, and the respective streams of oxygen and hydrogen are adjusted to give the minimum final gas stream, indicating that the proportions are correct. The argon is freed from traces of oxygen or hydrogen by passing through heated copper and copper oxide, and finally nitrogen is removed by an iron tube containing calcium turnings heated electrically to 600° C. Even in the laboratory it is possible to make argon at a rate of about 0.5 litres per hour.

For isolating argon in really large quantities, the fractionation of liquid air probably offers the most promise. Remembering that the boiling point of argon lies between those of nitrogen and oxygen, it will be understood that the intermediate fractions will be rich on argon, and various patents relate to the effective separation of the argon, mostly depending on a further fractionation in a separate column (cf. Claude, B.P. 3326/11; Linde, B.P. 24735/14; Filippo, Schoonenberg & Naamloze Vennootschap Philips Metal Gloelamp-fabrik, B.P. 101860/16; Fonda, (Gen. Elec. Co.), U.S.P. 1211125/17; Claude, *Comptes Rend.*, **166**, (1918), 492). Blockages are sometimes caused in liquid air plant by the separation of solid argon, which may lead to explosions on incautious heating to remove the obstruction. The final



concentration of the argon (*e.g.* oxygen + 20% argon) separated by the liquid air process may, of course, be completed by any of the above-mentioned processes, *e.g.* by combustion with hydrogen.

It must be remembered that the gas referred to above as argon, means in most cases a mixture of the whole of the rare gases of the atmosphere. This obtains with chemical means, but when made from liquid air a certain selection takes place.

As regards purification, this is most readily accomplished by treatment with metallic calcium or with lithium (Schloesing) for the removal of small quantities of nitrogen, and by fractional distillation or selective absorption with cooled charcoal (see below) for freeing from the other rare gases.

**Properties and Applications.**—Argon in common with the other rare gases, is distinguished from most other permanent gases by chemical inertness, and by monatomicity. Its chief physical constants will be found on pp. 53–55.

According to Kistiakowsky (1897), argon has the property of diffusing through caoutchouc some 100 times as fast as carbon dioxide; according to Dewar (1918), however (*cf.* p. 10), its rate is slower. On passage of the electric discharge through the rarefied gas, a brilliant red colour is obtained with continuous current; the colour of the discharge may be blue, however, under certain electrical conditions, *e.g.* with oscillatory currents. The change from red to blue is effected when using a continuous current by the incidence of Herzian waves, and an argon-filled Geissler tube may be used as a detector for electric waves. The spectrum is not very characteristic except when the gas is fairly pure, and is thus not of much assistance in detecting the presence of argon in nitrogen. A good criterion of the purity is to be found in the measurement of the dielectric cohesion.

Argon shares with the other rare gases the property of offering a low resistance to the passage of an electric spark; the value is increased to about  $2\frac{1}{2}$  times by the presence of 1% air or other impurity. It has been observed that at

low pressures, spluttering of the electrodes is more marked in the electric discharge in argon than in diatomic gases, and at a pressure of about 0.005-1 mm., argon causes a marked Edison effect in incandescent lamps, with increased blackening. At higher pressures its action is quite different.

Reference has already been made to the use of nitrogen in the "half-watt" metal filament lamp (p. 122). Increasing quantities of argon are now being employed, both alone and in admixture with nitrogen, for this purpose. The proportion of argon in admixture with nitrogen for lamp filling may be estimated (Hamburger and Filippo, *Z. angew. Chem.*, 28, (1915), 75) by comparing the vapour pressure on cooling in liquid air, with the pressures shown by standard mixtures.

#### NEON

**Occurrence.**—Neon occurs with the other rare gases in the atmosphere and also in mineral springs. In the atmosphere it is present to the extent of 0.0018 % being, next to argon, the chief constituent of the inert gas fraction.

**Isolation.**—The most convenient method of isolating neon is by the separation from air, either entirely by physical means or by physical treatment of the residue of inert gases produced by the chemical removal of the nitrogen and oxygen. Thus, neon was discovered by Ramsay in 1898 by the fractional distillation of crude argon.

According to Claude (B.P. 22316/09), neon and helium are separated in the fractionation of liquid air, by effecting the further fractionation of the last portions of the nitrogen fraction, *i.e.* the most difficultly liquefiable portions, which, still under pressure, are liquefied in a spiral cooled by the released and liquefied nitrogen. The "backward return" is used here as in oxygen and nitrogen production. It is possible in this way to obtain a gas containing some 50 % neon.

The further purification of the neon is best effected by fractional sorption with charcoal. It was shown by Dewar that at  $-100^{\circ}$  C., argon, krypton and xenon are absorbed,

while neon and helium can mostly be pumped off (cf. B.P.s 13638/04, 7808/05). By further treatment at  $-180^{\circ}$  C., the neon in turn is mostly absorbed, and nearly pure helium can be pumped off. On warming up the neon is disengaged in a fairly pure state. The purification is best followed by the density (cf. Table 12(A), p. 53).

Separation from helium can also be effected by cooling in liquid hydrogen, when the neon solidifies, while the helium (B.P.  $-269^{\circ}$  C.) can be pumped off (Dewar, *Roy. Soc. Proc.*, **67**, (1901), 329; **68**, (1901), 362). According to Collie and Patterson, the passage of an electric discharge through hydrogen is accompanied by the formation of traces of neon. Measurement of the dielectric cohesion is a good test of the purity.

**Properties and Applications.**—In the electric discharge tube, neon gives a brilliant orange pink incandescence; by means of the spectrum, the presence of neon in 0.1 c.c. of air can be detected. Neon has a very low dielectric cohesion, and is much less readily absorbed by the electrodes in a discharge tube than most other gases. It is on account of these characteristics that the chief application of neon arises, viz. its use for the Moore lamp. This lamp consists of a long glass electric discharge tube, e.g. 20 ft. in length and about  $1\frac{3}{4}$  ins. to 2 ins. in diameter, filled with neon to a pressure of about 2 mm. of mercury.

Using a potential difference of about 1000 volts and a current of 0.94 ampère, a spherical candle power of about 1300 is obtained. This is equivalent to a power consumption of 0.72 watt/mean spherical candle power, or 0.9 including the losses in the transformer. The power factor is about 0.8. In order to minimize the trouble experienced by absorption at the electrodes, very large cylindrical hollow copper electrodes are used, e.g. 6 cm.  $\times$  2.5 cm. By keeping the current density down to 1 amp./100 cm.<sup>2</sup>, a life of 400 hours or more can be obtained (cf. Claude, *Comptes Rend.*, **151**, (1910), 1122; **152**, (1911), 1377; Langmuir and Orange, *Amer. Inst. Elec. Eng.*, (1913), 1913, 1935). The colour effect can be corrected by using contiguous tubes containing

hydrogen. Using nitrogen in the discharge tube, some three times the potential difference is required, and only one-third the light is produced. In the case of a neon-filled tube, the intensity of the light is greatly reduced by the presence of nitrogen.

Neon is manufactured in Paris on a scale sufficient to fill some 1000 tubes of 1000 candle power, *i.e.* about 1 ft.<sup>3</sup> of neon, per diem. A liquid air plant producing 1750 ft.<sup>3</sup> of oxygen per hour, is stated to yield some 3.5 ft.<sup>3</sup> neon per diem.

Neon tubes can be used for the detection of Herzian waves.

### HELIUM

**Occurrence.**—Allusion has already been made to Ramsay's discovery of helium in 1894, by the ignition of clèveite. Its presence in other minerals containing radio-active elements, *e.g.* uranium and thorium, was subsequently discovered. Such minerals are fergusonite, samarskite, monazite sand, etc. It was discovered by Soddy in 1903, that helium is a product of the disintegration of radio-active bodies, the alpha particle shot off in such disintegration being, in fact, a charged helium atom.

The presence of helium in minerals has been the subject of much discussion by workers in radio-activity, the chief interest centering round the physical or chemical state of the helium in the mineral. Since the gas is only slowly expelled by heating, etc., the possibility of chemical combination seemed not out of the question. It was, however, demonstrated that practically all the helium could be liberated by very fine subdivision of the mineral; it appears, therefore, that the gas is imprisoned in very fine cavities, under a pressure of the order of 200 atmospheres.

Helium also occurs in the atmosphere (isolated by Kayser in 1895), in the sea, in meteorites, in the hotter stars, in mineral waters, *e.g.* the gases from the Bath springs contain 0.12 % helium, and those from the Wildbad springs 0.71 %, and in natural gas, which contains up to about 1 % helium (cf. Cottrell, *J. Soc. Chem. Ind.*, (1919), 121 T.).

**Manufacture.**—Probably the most convenient method of preparing helium is from one of the above-mentioned minerals. The elimination may be effected by heating the mineral to redness in an iron tube which has first been evacuated, or freed from air by displacement with carbon dioxide. A temperature of 1000–1200° C. gives better results, a porcelain tube being used. Alternatively, the mineral may be heated with sulphuric acid, which treatment gives twice the yield obtained on heating alone, but has the disadvantage of being very slow; or it may be fused with potassium hydrogen sulphate in a hard glass tube. With the sulphuric acid treatment, 100 grams of clèveite yield some 500 c.c. of helium, which is obtained in a fairly pure state after removal of the carbon dioxide. The cost of production in this way is about £1 per litre.

Purification from neon and argon is described under "Neon," the helium resisting sorption and liquefaction; the charcoal method gives the best results. Hydrogen may be separated in a similar way by reason of its greater sorption by charcoal at liquid air temperatures. Nitrogen and hydrogen may be removed by the action of metallic magnesium plus quicklime and of copper oxide respectively.

**Properties and Applications.**—Helium is the most difficultly liquefiable of all known gases, and was first liquefied by Kammerlingh Onnes (*Comptes Rend.*, **147**, (1908), 421), the requisite cooling being effected by the evaporation of liquid hydrogen under reduced pressure.

Under the influence of the electric discharge, a brilliant yellow incandescence is obtained. As in the case of argon, a helium discharge tube may be used for the detection of electric waves (Dorn, *Annalen*, [4], **16**, (1905), 784).

Next to hydrogen, helium is the lightest gas known, the weight of one litre at N.T.P. being 0.1785 gram. The use of helium for filling balloons has been proposed on account of its non-inflammability and its high lifting power, which is 92 % of that of hydrogen (cf. p. 233). Other advantages are the possibility of increasing the buoyancy by electrical or other heating, and the lower rate of diffusion

through the balloon fabric. During the war, a process of isolation of helium from natural gas by fractional distillation, has been worked out in America. It is stated that plants have been erected with an output of 50,000 ft.<sup>3</sup>/day of 93% helium, at a cost of about £20 per 1000 ft.<sup>3</sup> (*Chem. Trade J.*, **64**, (1919), 99; *Nature*, **102**, (1919), 487; Cottrell, *loc. cit.*, p. 130).

#### KRYPTON AND XENON

**Occurrence.**—Krypton and xenon were discovered by Ramsay in the dregs from some 30 litres of liquid air. They are present in very small proportions in the atmosphere (cf. Table 15), also in mineral springs, mine gases, etc.

**Isolation and Properties.**—Krypton and xenon are most conveniently isolated by the method proposed by Dewar (*Roy. Soc. Proc.*, **68**, (1901), 362), which depends on the fractional condensation of these, the most easily condensable of the permanent gases of the atmosphere. A tube packed with glass wool is cooled in liquid air, and air drawn through at a sufficiently reduced pressure to prevent condensation of other constituents. Krypton, xenon and a little argon are deposited on the glass wool in the solid form. The two elements can be separated owing to the difference in their vapour pressures at the temperature of liquid air, krypton 17 mm., xenon 0.17 mm.; the former can thus be pumped off, leaving the xenon. Charcoal may be employed at about  $-120^{\circ}$  C. in a similar manner (Valentier and Schmidt, *Sitzungsber. Kgl. Preuss. Akad. Wiss.*, **38**, (1905), 816).

Under the influence of the electric discharge, krypton gives a pale violet and xenon a sky-blue colour. There are at present no special applications for these gases.

#### Niton

Radium emanation or niton represents the first stage in the disintegration of radium, and has been shown to belong to the group of inert monatomic gases, having all the characteristics of a true gas. It is present in minute amount in the atmosphere, together with thorium emanation. It

is slowly converted into helium with increase to three times its original volume, its "period of decay" (to half value) being 3.8 days.

Niton exhibits a characteristic spectrum, like the other rare gases. Owing to its radio-active nature, niton is used to a considerable extent, though necessarily in very minute quantity, in the treatment of cancer, etc. For further details of this interesting element, reference must be made to works on radio-activity.

#### REFERENCES TO SECTION IV.

- Ramsay, "Gases of the Atmosphere." London, 1905.  
Briscoe, "Textbook of Inorganic Chemistry." Friend, Little, Turner and Briscoe. Vol. i. London, 1914.

## SECTION V.—OZONE

**Occurrence.**—Ozone occurs in minute quantities in the atmosphere, particularly in the upper strata. This distribution can be explained by the action of ultra-violet light, which is known to produce ozone, and which is largely absorbed before reaching the lower layers of the atmosphere. A considerable amount of work on this question has been carried out by Pring (*Roy. Soc. Proc.*, **90**, A, (1904), 204), who found that at an altitude of 7000 ft. the concentration was 0·00025 % by volume (0·005 gram/m.<sup>3</sup>), and at 11,700 ft., 0·00047 %.

Ozone is sometimes present in mineral waters, *e.g.* to the extent of 0·2 c.c./litre of water.

The presence of ozone in the upper strata of the atmosphere is of interest in connection with the colour of the sky on account of the blue colour of ozone. The amount present in the atmosphere at the surface of the earth, never exceeds 0·00001 %. Evaporation of water is operative in the production of small quantities of ozone.

**Properties.**—Ozone is a permanent gas of which the physical properties will be found on pp. 53–6. It has a faint blue colour and a powerful and characteristic odour which renders possible its detection by smell at a dilution of the order of 0·0002 % (Pring), while quite small concentrations have an irritant action on the mucous membrane.

Ozone is an allotropic modification of oxygen, consisting of three atoms of oxygen. Its constitutional formula is probably  $O = O = O$ . Its production from oxygen is strongly endothermic, thus—

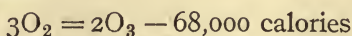

Like all endothermic gases, ozone is only stable at a very



high temperature. Thus, according to the Nernst Heat Theorem (Nernst, *Z. Elektrochem.*, **9**, (1903), 891), the equilibrium in oxygen would be about 10 % at a temperature of 6640° C., whereas at 3230° C. the corresponding value is 1 % and at 2183° C., 0.1 %. Consequently ozone is in a condition of metastability under ordinary conditions. At the ordinary temperature, however, the rate of decomposition is fairly slow. At 100° C. the decomposition is relatively rapid, while at 300° C. it is practically instantaneous. Conversion into oxygen is accelerated by the presence of various catalysts such as metallic oxides, chlorine, etc. According to Chapman and Jones (*Chem. Soc. Trans.*, (1910), 2463 ; (1911), 1811) the rate of decomposition is unaffected by the presence of nitrogen, carbon dioxide and possibly water vapour.

As a consequence of the above characteristics, ozone has very powerful oxidizing properties, generally furnishing one atom of free oxygen, the volume remaining constant, *e.g.* in the action on potassium iodide in solution, with liberation of iodine—



On the other hand, in some reactions, all three atoms of oxygen enter into combination, as, *e.g.* in the absorption of ozone by turpentine or oil of cinnamon.

In the presence of water, ozone attacks many metals. Thus, the properties of mercury are completely modified by the action of a mere trace of ozone, the metal becoming drossy, losing its convex surface and adhering to glass. Similarly, most organic substances are rapidly oxidized ; *e.g.* indiarubber cannot be employed in contact with ozonized air. Paraffin wax or concentrated sulphuric acid may be used as a lute.

By reason of its unstable nature, ozone has never been isolated in a state of even approximate purity in the gaseous state. The highest concentration which has been realized in the gaseous state, in oxygen, is some 28 % by weight (= 22 % by volume). Ladenburg (*Ber.*, **31**, (1898), 2508, 2830), however, by careful fractionation in the liquid state,

obtained an oxygen-ozone mixture containing about 86 % ozone, on the assumption that the formula is  $O_3$ .

There is, however, considerable doubt as to the correctness of this assumption, thus Harries (*Ber.*, **45**, (1912), 936; *Liebig's Annalen*, **390**, (1912), 235) considers that one-third or more of the "ozone" is really  $O_4$  or possibly  $O_6$ . This conclusion is based on a study of the constitution of certain ozonides. By the action of ordinary ozone, two distinct classes of ozonides are produced, one of which corresponds to the addition of  $O_4$ . On washing the crude ozonized gas with dilute caustic soda solution, the so-called "oxozone," *i.e.*  $O_4$ ,  $O_6$ , etc., is removed and a single ozonide results. Sir Joseph Thompson has shown that at least nine substances are formed by the passage of an electric discharge in oxygen (*Chem. News*, **103**, (1911), 265).

Liquid ozone has a dark blue colour, is not very mobile, and is more magnetic than liquid oxygen. It is a dangerous substance, as in contact with organic matter it explodes violently. The solid substance has not been described.

Ozone has a characteristic spectrum, and its solubility in water is probably of the same order as that of oxygen (*cf.* p. 93), but considerable uncertainty exists on this point.

### Production of Ozone

**General.**—The first recognition of ozone was by Van Marum in 1785, while much of the classical work which determined the constitution of this gas is due to Schönbein, Soret and Brodie. The difficulty of investigation was greatly increased by the fact that, except at very low temperatures, ozone could not be obtained in even an approximately pure state.

In consequence of the endothermicity of ozone, it is fairly obvious that the conditions suitable for its production from oxygen are the attainment of a very high temperature and then a rapid freezing of the equilibrium. Ozone is also produced in the liberation of oxygen from its compounds at the ordinary temperature.

The different methods of producing ozone may be classified under the following headings:—

- (a) Chemical methods.
- (b) By the thermal treatment of oxygen.
- (c) By electrolysis of aqueous solutions.
- (d) By photochemical means.
- (e) By the electric discharge in air or oxygen.

In connection with ozone production, it is usual to express the ozone content of air, etc., in terms of grams of ozone per cubic metre, the units being of a convenient order of magnitude. In some cases, however, the concentration is expressed as one part in a certain number of parts of air, and considerable confusion is due to the lack of clearness in many instances as to whether the basis of comparison is weight or volume.

It is useful to note that since 48 grams of ozone have at  $15^{\circ}$  C. a volume of 23.6 litres, one gram of ozone per cubic metre is equivalent to  $\frac{1}{20}$  % by volume, and since one cubic metre of air at  $15^{\circ}$  C. weighs 1225 grams, to about  $\frac{1}{2}$  % by weight. For the sake of simplicity, the formula is here taken as  $O_3$ .

(a) **By Chemical Methods.**—Ozone is produced in small amount during the slow oxidation of phosphorus in moist air, and by the action of fluorine on water. Better yields are obtained by the treatment of barium peroxide, potassium permanganate or potassium dichromate with concentrated sulphuric acid. With permanganate, the action is dangerous and should not be performed except with very small quantities. According to Malaquin (*J. Pharm. Chim.*, [viii.], 3, (1911), 329), good results are obtained by heating carefully to  $60$ – $70^{\circ}$  C. a mixture of 20 grams of ammonium persulphate and 15 grams of nitric acid of S.G. 1.33, in a flask from which the air has been displaced by a current of carbon dioxide. When freed from carbon dioxide, the gases contain some 3–4 % by volume of ozone and 4–4.5 % nitrogen.

(b) **By Thermal Treatment of Oxygen.**—While, as stated above, the equilibrium concentration of ozone in oxygen is calculated by Nernst as some 10 % at a temperature

of  $6640^{\circ}$  C., the equilibrium is so unfavourable at  $1000^{\circ}$  C. that 1 % of ozone is reduced to 0.001 % in 0.0007 second (Clement, *Annalen*, [4], 14, (1904), 334). Any process operating by simple heat treatment must obviously provide for very rapid cooling. Thus the Charpentier process depends on the rapid cooling of a flame by sudden dilution with a large volume of secondary air; it is claimed that an ozone concentration of 1 gram/m.<sup>3</sup> can be realized in this way. By heating a Nernst filament immersed in liquid oxygen to  $2000^{\circ}$  C. (Fischer and Brähler, *Ber.*, 39, (1906), 940; Fischer and Marx, *Ibid.*, 40, (1907), 1111), an ozone content of 3.9 % by weight was obtained.

When operating with a Nernst filament in dry air, some oxides of nitrogen may be formed according to the conditions, slow cooling being favourable. Thus with air linear velocity of about 16 ft./sec. for dry air, or 23 ft./sec. for moist air, both ozone and oxides of nitrogen are produced; below this speed only oxides of nitrogen result, while at a velocity of over 100 ft./sec., only ozone is formed. With a linear velocity of 206 ft./sec., an ozone concentration of 0.23 gram/m.<sup>3</sup> has been obtained with a production of 1.28 grams/K.W.H. (cf. Fischer and Marx, *Ber.*, 39, (1906), 2557, 3631; 40, (1907), 443; Fischer, B.P. 3692/07).

(c) **By Electrolysis.**—For the production of ozone by this method, the best yield is secured by the use of dilute sulphuric acid containing 15 %  $\text{H}_2\text{SO}_4$ . The conditions favouring the production of ozone are low temperature of the anode and electrolyte, and a high current density at the anode, e.g. 80 ampères/cm.<sup>2</sup>, a not too easy combination. Thus, by embedding platinum foil in glass and grinding away so as to expose the edge only, a concentration of 23 % ozone by weight (16.7 by volume) in the oxygen evolved was realized (Fischer and Bendixsohn, *Z. anorg. Chem.*, 61, (1909), 13, 153). In another series of experiments the anode was coated with glass except for a small slit, and maintained at a temperature of  $-14^{\circ}$  C., while the electrolyte was kept at  $0^{\circ}$  C. In this case the oxygen contained 28 % by weight of ozone (22 % by volume), and the yield was 7.1

grams/K.W.H. (Fischer and Massenez, *Z. anorg. Chem.*, **52**, (1907), 202, 229).

By superimposing an alternating current on the usual direct current, Archibald and v. Wartenberg (*Z. Elektrochem.*, **17**, (1911), 812) increased the concentration of ozone with reference to the oxygen liberated by the direct current, to 37 % by volume, the improvement being due to the depolarizing action of the alternating current, but dilution by the gas liberated by the alternating current reduced the percentage to 6 %. With a greater ratio of direct current to alternating current, the ozone corresponding to the direct current was, in one case, 15 %, that in the actual gas mixture 12 %.

(d) **By Photochemical Means.**—Ozone is produced by the action of ultra-violet light or electrical radiations on oxygen, and as with the silent discharge the action is reversible. According to Pring the maximum concentration attainable by the action of ultra-violet light is 0.15 % by volume, when using air, and 0.2 % with oxygen.

(e) **By the Electric Discharge.**—The only method of making ozone which possesses any technical importance, is that depending on the action of the so-called "silent discharge" on oxygen or air. On the other hand, the electric spark produces practically no ozone, as the gas is rapidly decomposed by the spark. The first form of ozonizer is due to Siemens in 1857 (*vide infra*).

The precise mechanism of the process is still somewhat obscure. It has been suggested that the action is an effect of ultra-violet light, and that the process is really a photochemical one.

Using this process, the efficiency is enhanced by (1) keeping the temperature low; (2) using oxygen instead of air; (3) drying the air or oxygen; and (4) increasing the pressure. Since the formation of ozone from oxygen is accompanied by a decrease in volume, it follows that an increase in pressure is favourable to ozone production. The question is, however, complicated at pressures above atmospheric by the effect of increased pressure on the

electric discharge itself. The result appears to be that the optimum pressure is about 1 atm. The action is a reversible one, and the highest concentration realized in this way at the ordinary temperature is about 25 % by weight = 18 % by volume (cf. also Goldstein, *Ber.*, **36**, (1903), 3042). Further details relating to this process will be found below.

By operating under reduced pressures at liquid air temperatures, Briner and Durand (*Comptes Rend.*, **145**, (1907), 1272) effected a conversion of 99 %. The best results were obtained at a pressure of 100 mm., the ozone liquefying out as it was produced, with consequent reduction of the pressure to 1 mm.

## MANUFACTURE OF OZONE

### General Principles of Ozonizers

**Influence of the Character of the Discharge.**—It has been mentioned above that the only commercially important method of making ozone is that depending on the action of the silent discharge. Generally speaking, ozonizers consist of two electrodes separated by a gaseous or solid dielectric, and maintained at a potential difference of the order of 10,000 volts while a stream of air or oxygen is passed through the apparatus. Alternating current is usually employed, being obtained by the use of a step-up transformer with a periodicity up to 500 cycles per second.

According to Warburg and Leithäuser (*Annalen*, [4], **28**, (1909), 1) the current density and consequently the ozone production, are roughly proportional to the frequency.

If direct current be employed, the use of points on the positive electrodes, combined with high current density, leads to the highest yields with moderate concentrations, e.g. 4 grams/m.<sup>3</sup>, while a reversal of conditions with a low current density favours the attainment of high concentrations e.g. 4-9 grams/m.<sup>3</sup> (Warburg and Leithäuser, *Annalen*, [4], **20**, (1906), 734).

Broadly speaking there are three types of electrodes: (1) large smooth electrodes, e.g. parallel plates or concentric

cylinders ; (2) electrodes with points : and (3) combinations of (1) and (2).

The production of ozone appears to be proportional to the current and independent of the voltage (Gray, *Annalen*, [4], 13, (1904), 477). Increase of capacity in the circuit is favourable to ozone production and large electrode area and short distance of separation operate in the same direction.

**Influence of Dielectrics.**—If the dielectric be air, the dividing gap is usually about 13 mm., and must not be decreased below 7 mm. (Vosmaer), and the maximum potential difference used is about 10,000 volts. No apparatus using air as dielectric appears to have had much success, and most modern forms use glass as a dielectric, the regularity of the discharge being increased and the danger of sparking thus being minimized.

Sparking is very detrimental as it leads to decrease of the ozone concentration and, moreover, to the formation of oxides of nitrogen. With a single thickness of 1–2 mm. of glass, a potential difference of 10,000 volts may be used, while 20,000–25,000 volts may be employed with double thickness. Using “vitresil” (fused silica), a potential difference of 30,000 volts is permissible with a thickness of 1 mm. This material has the further advantage of not losing its dielectric properties with increase in temperature in the manner exhibited by glass (Vosmaer).

**Relation between Energy, Concentration, and Production.**—The yields obtained in commercial apparatus vary greatly from one type to another, particularly as the design of some ozonizers is directed towards high efficiency, whereas that of others aims at simplicity and robustness at the expense of output, but when using dry air and keeping the temperature down, it may be taken that the relation between concentration and the yield per K.W.H. is somewhat as follows (cf. Erlwein, *Z. Sauerstoff u. Stickstoff Industrie*, 3, (1911), 130, 143, 164, 181):—

Concentration of ozone.							
Grams/m <sup>3</sup> . . . . .	1	2	3	4	5	6	7
Yield. Grams/K.W.H.	62	50	36	23	13	8	5

On account of the rapid falling off of the efficiency with increase in concentration, the latter is naturally kept at as low a value as possible for the particular application in question. With the usual commercial concentration of about 2 grams/m.<sup>3</sup>, and using dry air with efficient cooling, the yield is usually about 40-60 grams/K.W.H. On substituting oxygen for air, the production increases to 120-180 grams/K.W.H., even this being, of course, far below the theoretical yield corresponding to the expenditure of electrical energy (Erlwein, *loc. cit.*).

In comparing the costs of production of ozone by different ozonizers, it is important to see that the yields given are expressed in terms of an ozone concentration of 1-2 grams/m.<sup>3</sup>. The cost of production from air is consequently of the order of 1/3 to 1/9 per kilo. ozone, inclusive of overhead charges with current at about 0.5d./K.W.H.

**Influence of Moisture.**—The presence of moisture in the air or oxygen to be ozonized has a marked influence. Thus, the presence of 7 mm. of water vapour (about 1 % by volume) lowers the production by about 6 % in the case of oxygen and 30 % with air (Warburg and Leithäuser, *Annalen, loc. cit.*).

**Influence of Temperature.**—The effect of raising the temperature of the air to be ozonized from 20° C. to 80° C. is to decrease the production to about 60 % of its former value (Linder, *Trans. Amer. Inst. Chem. Eng.*, 3, (1910), 188), while the results given below were obtained by Warburg and Leithäuser (*loc. cit.*) from ozonizer tests with constant flow.

	Temperature °C.	Grams ozone per ampère hour.	Grams ozone/m. <sup>3</sup> .
Air .. .. .	20	467	1.76
	80	338	1.26
Oxygen .. .. .	18	429	0.49
	80	425	0.44

The following table gives the relation between the percentage of ozone and the temperature in the case of a particular ozonizer (not operating under commercial conditions), the



conditions otherwise being constant and oxygen being used (Beill, *Monatsh. Chem.*, **14**, (1893), 71).

Temperature °C.	-73	-46	-20	0	20	35	78	100	132
Percentage ozone (by volume) ..	10	9.2	7.9	5.2	4.7	3	1.3	0.8	0.3

At liquid air temperatures complete conversion can be realized, the ozone liquefying out as produced. By employing refrigeration in conjunction with an ozonizer, Steynis (cf. Linder, *loc. cit.*) claims to have secured a yield of 105–250 grams ozone/K.W.H., at a concentration of 4 grams/m<sup>3</sup>.

**Materials of Construction.**—In view of the action of ozone on steel, etc., various special alloys have been used in the construction of ozonizers and accessory plant, *e.g.* chrome steel, nichrome, aluminium alloys, etc. Shellac and “bakelite” also resist the action of ozone.

### Construction and Production of the Various Commercial Types of Ozonizers

As regards the patent literature relating to the manufacture and utilization of ozone, the specifications are so numerous and the value of the majority so doubtful, that it is impossible to deal with individual patents in the present volume, and information must be obtained from the Abridgements of Specifications, Class 90, for British Patents.

The first ozonizer was introduced by Siemens in 1857, and is typical of all others. In its original form it consisted of two concentric glass tubes with tin-foil inside the inner and outside the outer tube, the air or oxygen being passed through the annular space. A modification introduced by Berthelot was the replacement of the tin-foil by a liquid conductor, *e.g.* water, dilute acid, etc.

The commercial Siemens and Halske system consists of 6–8 glass tubes surrounded by water in a cast-iron casing. Aluminium electrodes disposed inside the glass tubes form one set of electrodes, while the water serves as the other electrode. Using 8000 to 10,000 volts, a yield of some 50

grams ozone/K.W.H. at a concentration of 2.5 grams/m.<sup>3</sup> is obtained.

The apparatus of the General Electric Co. is similar to the Siemens and Halske, but instead of aluminium, enamelled iron is used for the inner electrodes.

The older types of the Otto system employed a rotating central electrode consisting of aluminium discs in an iron cylinder in order to break up any spark discharges, no dielectric being used; in the later forms this method is abandoned and glass is used as a dielectric.

The Tindal de Frise system employs no dielectric and has a series of serrated semicircular aluminium discs, in a water-cooled iron trough. To prevent sparking, a series of glycerol-water resistances is included in the circuit.

In the Abraham-Marmier system, glass plates one square metre in area are interposed between water-cooled metal plates connected alternately to opposite terminals. Short-circuiting through the cooling water is prevented by the use of water showers.

The Ozonair system uses electrodes of aluminium alloy gauze separated by mica sheets, the air being passed between the plates. Several pairs mounted in a case form a unit. The use of the gauze is claimed to prevent sparking, while the open construction leads to efficient cooling without the use of water. The potential difference is about 7000 to 9000 volts.

According to the Howard-Bridge system a glass cylinder has an outer aluminium electrode and an inner concentric metal tube serving as electrode, through holes in which the air enters the ozonizer.

The original Vosmaer system employed no dielectric, the discharge passing between a toothed electrode and a plate. Sparking was prevented by the insertion of a condenser in the electrical circuit. A dielectric is used, however, in the later forms which consist of a series of cells in a casting of grid form, the separating walls being lined with glass plates, and each cell enclosing a sharp-edged electrode. In the units of 100-1000 watts capacity, a yield of more than

50 grams/K.W.H. at a concentration of 1 gram/m.<sup>3</sup> is claimed.

The Gérard system, made by the Westinghouse Co., makes use of a double dielectric consisting of two concentric glass tubes with metallic sheathings inside the inner and outside the outer tube respectively. The air is passed between the tubes. Groups of about 10 elements are mounted in a tank filled with oil. Very high production, viz. 80 grams/K.W.H. at a concentration of 3 grams/m.<sup>3</sup>, is claimed.

### Applications of Ozone

**Water Sterilization.**—Of the various applications of ozone, the sterilization of potable water is the most important. The problem of the sterilization of drinking water, *i.e.* the removal of the bacteria, or at any rate most of the pathogenic ones, can be solved in a variety of ways. Among these may be mentioned (1) sand filtration; (2) treatment with chlorine and subsequent removal of the excess by means of sodium sulphite or other suitable “anti-chlor”; (3) treatment with ozone; and (4) treatment with ultra-violet light. Of these sand filtration is most commonly adopted when dealing with waters not specially contaminated. The use of chlorine, etc., although very effective as regards sterilization, is not very suitable for the preparation of potable water, except in special cases, as *e.g.* in the field, on account of the usual residual taste imparted to the water. Ultra-violet light has an effect on the water similar to that of ozone, but the ultra-violet light treatment is useless if the water be even slightly turbid.

Ozone treatment has many advantages in that the slight excess left in the water is unimportant since it rapidly disappears, also the taste of the water is unaffected either by noxious products or by action on the salts to which drinking water owes its pleasant taste. In treating water with ozonized air, it is important that the water should be free from suspended matter, from organic matter, and iron, as ozone is used up thereby. Some 50 % of any organic

matter is oxidized by the ozone, all three atoms of oxygen participating in the reaction, while any organic iron is converted into ferric hydroxide which separates out and clogs up the plant. The preliminary removal of ferrous iron is effected by aeration, that of ferric iron is difficult except by the ozone treatment, and it is therefore often necessary to remove the precipitated ferric hydroxide by subsequent filtration or by similar treatment. The ozone required varies according to the amount of organic matter in the water; it may lie between 2 and 35 grams/1000 galls. of water, but averages about 10 grams/1000 galls.

The concentration of the ozone should be from 2 to 2.5 grams/m.<sup>3</sup> of air, although a concentration of only 1 gram/m.<sup>3</sup> is sometimes employed, *e.g.* at St. Maur. It follows that the volume of air is roughly equal to that of the water, when ozone is used in concentration of 2 grams/m.<sup>3</sup>, since 10 grams of ozone are present in 5 m.<sup>3</sup> = 1100 galls. of air. After the ozone treatment, only the harmless bacteria remain in the water.

Broadly speaking there are three main types of plant for the treatment of water with ozonized air: (1) those operating with towers filled with packing, down which the water trickles meeting the ascending current of ozonized air; (2) those depending on the use of a tower fitted either with horizontal perforated plates, the ozonized air and water flowing in co-current upwards, or without baffles and with the water flowing downwards in counter-current; and (3) those in which the air is injected in the form of small bubbles into a rapidly moving column of water.

In all cases, the object is to effect very intimate contact between the water and the sparingly soluble ozone, the action of which when once in solution is very rapid. Of the three systems, (2) probably gives the most efficient contact. In most modern plants, a combination of the above systems is adopted, the water being first put through a sand filter.

In class (1), we have the Siemens and Halske and the Abraham-Marmier systems. Towers packed with stones

or the like are employed, and the unused ozone is returned to the ozonizer.

To class (2) belongs the Siemens de Frise system, being a combination of the Siemens and Halske ozonizer and the De Frise scrubber. In this case, the ozonized air is injected into the bottom of a tower fitted with perforated baffle plates which serve to break up the air into small bubbles. The Vosmaer system, on the other hand, employs no baffles and has counter-current flow. The Gérard and Tindal systems are similar to the above.

The Otto system represents class (3), and depends on the emulsification of the air by a Körting injector operated by the water. The injector sucks in the air, the action being completed by continued contact in passing down a vertical pipe, some 15 feet in length. One objection to the Otto system is the comparatively small volume of air taken in, and the consequent necessity for the high ozone concentration of 3 grams/m.<sup>3</sup>. The Howard-Bridge system is similar. In the Ozonair system, the water is first atomized into ozonized air in the upper part of a tower of which the lower part is occupied by packing. The ozonized air is injected through special nozzles into the water in a tank which is fed by water flowing down the tower, and then passes on to ascend the tower. After treatment, the water is exposed to the atmosphere by flowing down a series of steps, in order to remove the excess of ozone.

As regards power requirements, it can be stated that for 1000 galls. of water, from 0.2 to 0.7 K.W.H. is usually required, while the cost (pre-war) varies from  $\frac{1}{3}d.$  to 1d., plus overhead charges, per 1000 galls.

There has been little application of the ozone treatment of water in this country, chiefly on account of the high quality of the water used in most English towns. An Ozonair plant has, however, been installed in Knutsford. There are many plants on the Continent and in America. A plant at Paris, for example, treats some 400,000 galls. of water per hour.

The air to be ozonized is dried by the use of calcium

chloride or, preferably, by refrigeration. The ozonizers are always connected in parallel, about 10,000 volts generally being used. According to Vosmaer, the difficulty of packing materials for the pumps used in the injection of the ozonized air is overcome by the use of celluloid piston rings.

Portable ozone outfits were used for treatment of water in the field by the Russian Army in the Russo-Japanese war.

Small apparatus for attachment to any ordinary household water-tap are on the market, mostly working on the filter pump (Otto) system.

**Air Purification.**—Ozone is used on a considerable scale for freshening the air in crowded buildings, underground railways, hospitals, abattoirs, cold stores, etc. It has also been used with success in breweries for the air of fermentation rooms, etc., having a beneficial effect on the yeast, probably due to the elimination of adventitious enzymes.

On account of the irritant properties of ozone, it is not possible to use concentrations sufficiently high to exhibit any marked germicidal effect. Thus, bacteriological action requires a concentration of about 0.5 gram/m.<sup>3</sup>, while the highest concentration in which breathing is tolerable is of the order of 0.001 gram/m.<sup>3</sup>. Ozone is, however, efficacious in removing the noxious organic exhalations present in crowded rooms, much of the discomfort of "stuffiness" being due to the presence of these organic compounds. At the same time an agreeable freshness is imparted to the air. For the best results, according to Vosmaer, the ozone should be present to the extent of 0.0001 gram/m.<sup>3</sup>, and in any case, not more than 0.001 gram/m.<sup>3</sup> is permissible. At such a low concentration the yield is of the order of 100 grams/K.W.H.

The Central London (Tube) Railway is supplied with ozonized air by the Ozonair system. The procedure in this case, which is typical of similar installations, is as follows. The air is drawn by a fan through a gauze screen filter moistened with a spray of water which retains dust and cools the air. A small fraction of the air is then dried and led through the ozonizer, after which it is returned to the main

stream. Most of the plants on the above railway treat some 360,000 ft.<sup>3</sup> of air per hour; the cost is stated to be 1.7*d.* per million ft.<sup>3</sup> of air treated (pre-war). Small plants of 20 to 25 watts capacity are made for use in rooms of 3000 ft.<sup>3</sup> content.

**Chemical Applications.**—Ozone also finds application in the manufacture of various organic compounds, its function being that of an oxidizing agent. Thus, it is used on a fairly extensive scale in the manufacture of artificial vanillin from isoeugenol, a factory at Courbourg, Paris, employing a 100 H.P. plant for making vanillin by the Verley process. A similar plant is also in operation at Niagara.

Ozone is employed in the manufacture of artificial camphor (Schering) and artificial silk, for the bleaching of oils, waxes, sugars, etc., in the production of ozonides (*e.g.* of caoutchouc), scents and in many other organic reactions. It has been applied with success to the production of transparent varnish from linseed oil, also to the refining of the same.

**Other Applications.**—Among miscellaneous applications may be cited the sterilizing of barrels, the bleaching of delicate fabrics, etc. The application of ozonized air to the bleaching of flour has not been successful as the flour is affected adversely. Ozone has been tried for such purposes as the ageing of wines, the maturing of timber, tobacco, etc., but in many cases the success is doubtful. Recent experiments on the treatment of wounds with ozone have shown the efficacy to be questionable.

**Detection and Estimation of Ozone.**—In the absence of other oxidizing agents, ozone is readily detected by its action on potassium iodine paper with liberation of iodine (*cf.* p. 135). Since, however, other substances such as chlorine, oxides of nitrogen, etc., produce the same effect, it is necessary to have some means of discrimination.

A simple method is to use paper moistened with both potassium iodide and phenolphthalein. The action of ozone differs from that of other oxidizing agents in that it results in the formation of potassium hydroxide. A better selective test depends on the use of moistened tetramethyl

di-*para*-aminophenylmethane paper, which exhibits the following colour reactions:—

Ozone	..	..	..	..	violet.
Chlorine, bromine	..	..	..	..	deep blue.
Oxides of nitrogen	..	..	..	..	straw yellow.
Hydrogen peroxide	..	..	..	..	no action.

One of the best methods of estimating quantitatively the amount of ozone in air, oxygen, etc., is by potassium iodide, with subsequent titration of the iodine after acidification. If other oxidizing agents are present the ozone may be estimated by repeating the estimation after passing the gas through a tube heated to about 260° C., and then determining the difference in the iodine liberation due to the decomposition of the ozone, this difference giving the initial ozone concentration.

A more positive method consists in removing the oxides of nitrogen by means of caustic soda, while hydrogen peroxide may be eliminated by passing over finely divided crystals of chromic acid.

According to Usher and Rao (*Chem. Soc. Trans.*, (1918), 799), ozone present in small quantity is best estimated by drawing the air through (1) chromic acid plus manganese dioxide, (2) chromic acid alone. In both cases hydrogen peroxide is removed and in (1) nitrogen peroxide also is eliminated; on shaking up with sodium nitrite solution and subsequently estimating the degree of conversion into nitrate, the difference in the two cases gives the ozone content.

Separation of ozone from oxides of nitrogen may also be effected by passing into liquid air, when the ozone dissolves but the oxides of nitrogen separate out as blue flocks.

#### REFERENCES TO SECTION V.

- Vosmaer, "Ozone, its Manufacture, Properties and Uses." New York, 1916.  
 Fonrobert, "Das Ozon." Stuttgart, 1916.  
 Harries, "Untersuchungen über das Ozon und seine Einwirkung auf organische Verbindungen." Berlin, 1916.



- Anon., "The Use of Ozone for Chemical Research and Industries," *Chem. News*, **113**, (1916), 193, 205.
- Erlwein, "Herstellung und Verwendung des Ozons," *Z. für Stickstoff und Sauerstoff Industrie*, **3**, (1911), 130.
- Ziegenberg, "Die elektrische Ozontechnik." Leipzig, 1910.
- Perkin, "The Industrial Uses of Ozone," *Nature*, **88**, (1912), 551.
- Rideal, "Water Supplies." London, 1916.
- Don, "The Filtration and Purification of Water for Public Supply," *Engineering*, **87**, (1909), 126, 160.
- Anon., "Water Sterilization Plant at St. Petersburg," *Engineering*, **91**, (1911), 656.

## PART II.—HYDROGEN, CARBON MONOXIDE, CARBON DIOXIDE, SULPHUR DIOXIDE, NITROUS OXIDE, ASPHYXIATING GASES

### SECTION VI.—HYDROGEN

**Occurrence.**—Hydrogen is present in small amount in the atmosphere, 0·019 % according to Gautier, 0·003 % according to Rayleigh, its origin being the fermentation of cellulose, etc., by anærobic micro-organisms.

**Physical Properties.**—Hydrogen is a colourless, tasteless and odourless gas. It is the lightest known gas, the weight of one litre at N.T.P. being 0·089873 gram. The solubility in water is given in the following table :—

Temperature °C.	0	10	15	20
C.c. of gas (measured at N.T.P.) dissolved by 1 c.c. of water under a pressure of 1 atm. exclusive of water vapour.	0·0215	0·0198	0·0190	0·0184

The mean specific heat at constant volume is given by Crofts (*Chem. Soc. Trans.*, (1915), 290) as—

$$C_v = 2·41 + 0·00032t$$

where  $C_v$  is the mean specific heat between  $t$  and 15·5° C.

Hydrogen does not show the preliminary decrease, common to other permanent gases, of the product  $pv$  as the pressure is increased, but gives a continuous increase, the departure from constancy being very considerable at 200 atms. (cf. p. 3). Due allowance for the diminished quantity of hydrogen, represented by the expression  $p/pv$ , is important when calculating the volume of gas in a cylinder from the pressure. Thus a cylinder of actual volume of 1 ft.<sup>3</sup> only contains 111·8 ft.<sup>3</sup> of free hydrogen at 121 atms. absolute pressure for a temperature of 16° C., in both cases (cf. pp. 4, 5).

Hydrogen is occluded to a considerable extent by many

metals, such as palladium, platinum, iron, cobalt, etc. Palladium has the property in the highest degree. The volume occluded varies little with pressure between 1 and 4.6 atms., but is dependent on the temperature. Thus, one volume of palladium sponge occludes 917 volumes of hydrogen at  $-50^{\circ}\text{C}$ ., the quantity falling off with rising temperature to a minimum of 661 volumes at  $20^{\circ}\text{C}$ . and then increasing to 754 volumes at  $105^{\circ}\text{C}$ . (Gutbier, *Ber.*, **46**, ii., (1913), 1453). Palladium black and palladium foil show a closely similar behaviour.

It was observed by Holt, Edgar and Firth (*Z. physik. Chem.*, **82**, (1913), 513) that palladium may be either active or passive according to treatment. These authors conclude that the hydrogen exists in two forms, (1) an adsorbed layer of high vapour pressure and easily removed by evacuation, and (2) an absorbed fraction irregularly distributed through the body of the metal. The sorption is accompanied by the evolution of 4370 calories per gram hydrogen, while the palladium increases in volume by some 10 %. *In vacuo*, at the ordinary temperature, 92–98 % of the hydrogen is disengaged and expulsion is complete at  $440^{\circ}\text{C}$ .; with foil most of the hydrogen is lost at  $100^{\circ}\text{C}$ . Under high pressure the hydrogen is retained even at a dull red heat, *e.g.* Dewar showed that 300 volumes were absorbed at  $500^{\circ}\text{C}$ . under 120 atms. pressure (*Chem. Soc. Proc.*, **13**, (1897), 192).

The solubility of hydrogen in other metals is fairly marked, *e.g.* platinum black at the ordinary temperature dissolves 110 volumes (Mond, Ramsay and Shields, *Phil. Trans.*, A **186**, (1895), 657), spongy platinum only a few volumes, reduced iron 9.4 to 19.2 volumes, reduced cobalt 59 to 153 volumes, reduced nickel 17 to 18 volumes (Graham, *Phil. Mag.*, [4], **32**, (1886), 503; Neumann and Streintz, *Annalen*, **46**, (1892), 431); cf. also p. 9.

Palladium, and in a lesser degree platinum and other metals, show a marked permeability to hydrogen, thus 1 m.<sup>2</sup> of palladium foil of 1 mm. thickness permits the passage of 325 c.c. hydrogen per minute at  $265^{\circ}\text{C}$ ., and of 3992 c.c. at about  $1000^{\circ}\text{C}$ . (Graham, *Roy. Soc. Proc.*, **16**, (1867–68),

422). Similarly platinum foil 1.1 mm. in thickness passes 489 c.c./min./m.<sup>2</sup> at a bright red heat. (Graham, *Phil. Mag.*, [4], 32, (1866), 401.)

On account of its high coefficient of diffusion, hydrogen easily passes through slightly porous bodies, *e.g.* indiarubber is markedly permeable to hydrogen (cf. p. 10), while quartz is appreciably so at temperatures above 1000° C. For other properties see Tables 12 and 13, pp. 53-6.

**Liquid Hydrogen.**—Hydrogen at ordinary temperatures is distinguished from most other gases by the fact that, on expanding without performing external work, heating takes place (cf. p. 67): Consequently, in the production of liquid hydrogen, the Joule-Thomson effect can only be realized after a preliminary cooling. In the British Oxygen Co.'s apparatus, this is effected by passing the hydrogen at a pressure of about 200 atms. through (1) a heat-interchanger, (2) coils immersed in liquid air, (3) coils cooled by the ebullition of liquid air, and (4) a second heat-interchanger, after which expansion takes place. The unliquefied hydrogen passes back over the coils, in counter-current to the incoming gases, to the gas-holder. Liquid hydrogen was first obtained in quantity by Dewar in 1898.

**Properties.**—Liquid hydrogen is a colourless, transparent liquid, a non-conductor of electricity; it is the lightest known liquid, having a density of 0.070 at the boiling point. The surface tension is 1/35 that of water. Specific heat is 6.4. When evaporated under reduced pressure, solidification takes place.

In spite of its low boiling point, liquid hydrogen is easily preserved, as the residual air in the Dewar vessels is frozen out and the vacuum made more perfect.

*Solid hydrogen* is colourless, its melting point is -258° C., the triple point -258° C. at 55 mm. pressure, and the latent heat of fusion 16 calories.

**Chemical Properties.**—At ordinary temperatures, hydrogen does not behave as an active element, entering into direct combination with only a few elements and compounds, *e.g.* the halogens, and even then usually only under the

influence of light or of catalysts. On heating, hydrogen reacts with alkali and alkaline earth metals to give crystalline compounds, *e.g.* NaH, CaH<sub>2</sub>, which are decomposed by water with evolution of hydrogen.

Mixtures of hydrogen and air are inflammable within the limits 74.2-4.1% hydrogen (*cf.* p. 40).

An important characteristic of hydrogen is its power of acting as a strong reducing agent, *e.g.* in the reduction of metallic oxides. Under high pressures hydrogen will directly displace many metals from solutions of their salts with liberation of free acid. Many reductions depend on hydrogen being liberated in the so-called nascent state, *e.g.* by action of metals, metallic couples, amalgams, etc., on water, dilute acids or alkalis. Electrolytically liberated hydrogen is similarly very active as a reducing agent and its effectiveness is largely dependent on the overvoltage of the cathode used.

Hydrogen is also active in aqueous solution in the presence of spongy or colloidal platinum, osmium and the like—thus, chlorate solutions are reduced (Hofmann and Schneider, *Ber.*, 48, (1915), 1585), nitrates are converted into ammonia, etc.

Palladium black induces the combination of a mixture of hydrogen and air so energetically that incandescence and inflammation ensue.

Sabatier (*Ber.*, 44, (1911), 84) opened out a vast field of possibilities by his researches on organic reductions by hydrogen in the presence of a moderately heated catalyst, *e.g.* nickel or platinum. Thus, carbon monoxide is reduced to methane by passing over nickel at 250° C., and similarly, unsaturated organic compounds such as oils are converted into saturated compounds. Further reference will be made to this important subject under "Applications of Hydrogen."

## MANUFACTURE OF HYDROGEN—STATIONARY PLANTS

**General.**—The manufacture of hydrogen occupies probably the most interesting place in the field of industrial gas technology in the variety of the methods employed. The production of pure and cheap hydrogen, which is now

required for various recent developments such as the synthesis of ammonia and the hydrogenation of fats, is a matter of very considerable difficulty, and quite a large volume of patent literature now relates to this subject.

Most of the processes having any technical importance at the present time start from coal (or coke) and water.

In comparison with gases such as nitrogen and carbon dioxide there are relatively few sources of hydrogen in the form of a waste product, but there are some cases where development is desirable, *e.g.* the waste hydrogen resulting from the electrolytic alkali industry and from the manufacture of electrolytic oxygen. Further, large quantities of hydrogen are liberated in the manufacture of oxalates by the fusion of sawdust or corncobs with caustic alkalis. During the war some of these sources of hydrogen have been tapped for aeronautical purposes, but in peace times large quantities of such hydrogen have been blown to waste.

Hydrogen is also produced as a by-product together with carbon dioxide in the manufacture of synthetic acetone by the fermentation process (*cf. J. Soc. Chem. Ind., (1919), 155 T*).

#### MANUFACTURE FROM WATER GAS—REPLACEMENT OF CARBON MONOXIDE BY HYDROGEN

There are two main methods of effecting the replacement of carbon monoxide in water gas by hydrogen—(1) the continuous catalytic process mainly due to the Badische Anilin & Soda Fabrik; (2) the Griesheim-Elektron process; both processes depend on the interaction of carbon monoxide with steam giving carbon dioxide and hydrogen.

Water gas has the following approximate percentage composition:—

Hydrogen .. ..	49
Carbon monoxide .. ..	42
Carbon dioxide .. ..	4
Nitrogen .. ..	4.5
Methane .. ..	0.5
	<hr/>
	100.0

The reversible reaction—

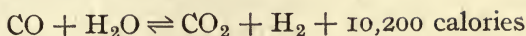

gives the so-called water gas equilibrium, provided that sufficient time be allowed.

$$K = \frac{p_{\text{CO}} \times p_{\text{H}_2\text{O}}}{p_{\text{CO}_2} \times p_{\text{H}_2}}$$

or,

$$\frac{p_{\text{CO}}}{p_{\text{CO}_2}} = \frac{p_{\text{H}_2}}{p_{\text{H}_2\text{O}}}$$

This equilibrium is dealt with on p. 309, under "Water Gas."

From an industrial standpoint the desideratum is to convert as much carbon monoxide as possible into the easily removed carbon dioxide, *i.e.* to make the fraction  $p_{\text{CO}}/p_{\text{CO}_2}$  as small as possible.

The variation of  $K$  with temperature is shown in the following table; the higher values are experimental but those below  $700^\circ \text{C}$ . are based on an extrapolation of the formula

$$\log K = -\frac{2116}{T} + 0.783 \log T - 0.00043T$$

which fits those actually observed.

Temperature °C.	..	400	500	600	700	800	900	1000
K. .. .. .	..	0.06	0.16	0.32	0.58	0.90	1.25	1.62

It is evident that at comparatively low temperatures the conditions are much more favourable for the conversion of carbon monoxide into carbon dioxide than at high temperatures.

Thus, if equal volumes of steam and hydrogen be present in the gas after treatment, a condition secured by taking about 1.4 volumes of steam per volume of water gas, the ratio

$$\frac{p_{\text{CO}}}{p_{\text{CO}_2}} = K \frac{p_{\text{H}_2}}{p_{\text{H}_2\text{O}}} = K$$

The carbon dioxide production is further enhanced by maintaining a high  $p_{\text{H}_2\text{O}}/p_{\text{H}_2}$  ratio up to a certain point above which the dilution with steam lowers the reaction velocity and output so much that the favourable effect on the equilibrium is counterbalanced.

We have seen that a low temperature is desirable ; below about  $400^\circ \text{C.}$ , however, the reaction velocity becomes so small that equilibrium cannot conveniently be attained. Further, it will be seen that even under favourable conditions the removal of carbon monoxide cannot be complete.

There are two obvious ways of furthering the carbon monoxide removal—(1) by working at a low temperature, a sufficiently great reaction velocity being attained by the use of an active catalyst ; (2) by disturbing the normal water gas equilibrium through the introduction into the system of an absorbent for carbon dioxide, *e.g.* lime.

On these two principles are based the processes of the Badische Anilin & Soda Fabrik and the Chemische Fabrik Griesheim-Elektron respectively.

It is clear that variation in the pressure will be without influence on the equilibrium ; it should be mentioned that reaction may take place between hydrogen and carbon monoxide or carbon dioxide in the absence of water. When a mixture of hydrogen with carbon monoxide or carbon dioxide is passed over reduced nickel at  $250^\circ \text{C.}$ , the following reactions take place (Sabatier and Senderens, *Comptes Rend.*, **134**, (1902), 514, 689) :—

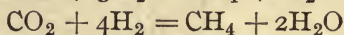
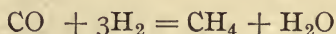

giving a very complete removal of the carbon monoxide if the hydrogen be in excess. These reactions are exothermic and therefore proceed less completely in the direction of methane formation at higher temperatures, *e.g.* at  $500^\circ \text{C.}$  ; a certain amount of methane may be formed, however, unless the catalyst be selected to favour the water gas reaction as is the case in actual practice.



### (1) B.A.M.A.G. Continuous Catalytic Process

The main development of the continuous catalytic process is due to the Badische Anilin & Soda Fabrik, but some other important patents are included below.

According to Hembert and Henry, in B.P. 1193/84, steam is blown through incandescent coke and the resulting water gas, mixed with excess steam, passed into retorts packed with fireproof materials, at a red heat. Carbon dioxide and hydrogen are thus formed and the former is subsequently removed by lime. Similarly, Read, in B.P. 3776/85, proposes to use heated metallic oxides as catalysts. The carbon dioxide formed is subsequently removed by alkalis, absorption in water under pressure, etc. In B.P. 12608/88, Mond and Langer prescribe the elimination of carbon monoxide and hydrocarbons from fuel gases by passing with excess steam over metallic nickel or cobalt at a comparatively low temperature, namely, 350–400° C. with nickel, 400–450° C. with cobalt. Pumice soaked in nickel chloride solution may be used. Carbon dioxide is removed by known methods and the gas is claimed to be almost free from carbon monoxide. F.P. 375164/06 of the Compagnie du Gaz de Lyons, relates to the use of iron oxide at 600° C., while Näher and Müller, in B.P. 20486/11, propose the use of palladium—or rhodium—asbestos at about 800° C. After three treatments the carbon monoxide is claimed to be reduced to 0.4 %.

None of the above mentioned patents met with technical success and the commercial development of the process by the use of active catalysts, as set forth in the following series of patents, is due chiefly to the Badische Co.

According to B.P. 26770/12, hydrogen is manufactured by the interaction of carbon monoxide and steam under pressure in presence of a catalyst at a temperature of *e.g.* 300–600° C. A pressure of 4–40 atms. is used to accelerate the reaction. Iron or nickel may be used as catalyst. Carbon monoxide is almost entirely removed. The process is stated to be specially suitable for gases containing only little carbon monoxide; in such a case the enhanced heat regeneration

under pressure is a further advantage since the heat evolution is small. The use of pressure does not appear to have been developed in practice.

B.P. 27117/12 relates to the maintenance of the temperature in the above process by the catalytic combustion of small quantities of oxygen added to the gases. Further, the steam required for the reaction may be thus supplied if only a little carbon monoxide be present. In B.P. 27955/12, a number of catalysts for the above reaction are described, all with a basis of finely divided iron oxide; the working range is from 400–500° C. and heating to over 650° C. is to be avoided. B.P. 8864/13 deals with catalysts consisting largely of nickel or cobalt; according to D.R.P. 297258/14, the metals should be disposed in small quantities on suitable supports and should be derived from salts free from sulphur and halogens. Further catalysts are given in B.P. 27963/13. When using nickel as catalyst, methane is formed and it is here claimed that such methane formation may be avoided by using catalysts consisting largely of iron in conjunction with nickel, chromium, etc. The catalysis is very rapid and suitable also for small quantities of carbon monoxide. Working temperatures are about 400–600° C. B.P. 16494/14 relates to the use of spathic iron ore as catalyst, heating to above 650° C. being avoided; a binding agent, such as  $\text{Al}(\text{OH})_3$ , may be added for briquetting purposes. In D.R.P. 284176/14, the use of the oxides of rare earths, especially of cerium oxide, in conjunction with other activants, is recommended.

A different class of catalyst is specified by Buchanan and Maxted in B.P. 6476/14, which protects the use of lixiviated alkaline ferrite. One passage gives a gas containing 28 % carbon dioxide and 2 % carbon monoxide. In another patent, B.P. 6474/14, the same inventors propose the use of metallic couples such as iron + copper, *e.g.* sodium ferrite treated with a copper salt. The couple is heated to 500° C. and a mixture of carbon monoxide with hydrogen passed over together with excess steam. An iron + silver couple is stated to be very active.

The process founded on the above Badische patents is claimed by the Berlin Anhaltische Maschinenbau Aktien-Gesellschaft (B.A.M.A.G.) to be the cheapest of all processes for making hydrogen on a very large scale. It is used by the Badische Co. at Oppau for the manufacture of synthetic ammonia. One obvious advantage of the process is the fact that whereas other methods require 2-5 volumes of water gas per volume of hydrogen produced, little more than 1.1 volumes are necessary in this case. Since water gas costs about 4*d.* per 1000 ft.<sup>3</sup> (pre-war) the effect of this difference may easily be estimated. Further, as the reaction is exothermic, it is easy by means of heat-interchangers and careful external lagging to make the supply of heat unnecessary except on first starting up. A temperature of 400-500° C. is maintained in the contact mass; little attention is required, there being no valves to operate, and one man can look after several contact sets. Starting with water gas mixed with the desired excess of steam—exhaust steam may be used—the gases issuing from the catalyst chamber, when freed from excess steam by cooling, have a percentage composition somewhat as follows:—

Hydrogen	..	..	..	65
Carbon monoxide	..	..	..	1-2
Carbon dioxide	..	..	..	30
Nitrogen, methane, etc.	..	..	..	4

The gases are compressed to about 25-50 atms. and freed from carbon dioxide by counter-current scrubbing with water while under pressure, the energy of the water issuing from the scrubber being largely recovered by means of a turbine. For data on the solubility of carbon dioxide in water under pressure, cf. p. 256. Final removal of the carbon dioxide may be effected with alkali solution, also under pressure.

On passage through the catalyst, all the sulphur compounds in the water gas—which needs no special purification except from dust and tar—are converted into sulphuretted hydrogen which is removed with the carbon dioxide.

If necessary, the remaining 1.5–3 % carbon monoxide is extracted by an auxiliary process.

Plants are constructed up to a capacity of about 35,000 ft.<sup>3</sup> hydrogen per hour. A life of six months is claimed for the catalyst. Before the war the only plant known to be in operation was that at the works of the Badische Co. It is claimed that the process can produce hydrogen at the low cost of 1/9 per 1000 ft.<sup>3</sup> (pre-war); taking into consideration the fact that each volume of water gas produces approximately its own volume of hydrogen, together with the continuous and comparatively simple nature of the operations, this would not seem improbable. It should be observed that the presence of some 4 % nitrogen is a serious disadvantage in certain applications, *e.g.* in aeronautics. The method is eminently suited from this point of view for the synthetic production of ammonia; by the addition of air to the steam in the "make" period of the water gas manufacture, any desired nitrogen-hydrogen mixture may be produced (*cf.* p. 207). A certain amount of methane will always occur in hydrogen made by this method.

**Theory of the B.A.M.A.G. Continuous Catalytic Process.**—Assuming the water gas to have the following percentage composition:—

Hydrogen	..	..	..	50	✓
Carbon monoxide	..	..	..	42	✓
Carbon dioxide	..	..	..	4	
Nitrogen	..	..	..	4	
				100	

and the temperature of the catalyst to be 500° C., it is interesting to calculate the theoretical result of using 100 volumes of water gas and 300 volumes of steam, both measured at the same temperature.

We then have

$$\frac{p_{\text{CO}}}{p_{\text{CO}_2}} = K \frac{p_{\text{H}_2}}{p_{\text{H}_2\text{O}}} = 0.16 \frac{p_{\text{H}_2}}{p_{\text{H}_2\text{O}}}$$

If we express the original condition of the gas mixture in

terms of partial pressures in atmospheres, we have the following values :—

$p_{\text{H}_2\text{O}}$	..	..	..	0·750
$p_{\text{H}_2}$	..	..	..	0·125
$p_{\text{CO}}$	..	..	..	0·105
$p_{\text{CO}_2}$	..	..	..	0·010
$p_{\text{N}_2}$	..	..	..	0·010
				1·000

The equation

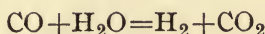

indicates that no change in volume takes place during the reaction.

Consequently, if we take the change in partial pressure of the carbon monoxide in the interaction as being represented by  $x$ , it may easily be seen that the final partial pressures of the reactants will be

$p_{\text{H}_2\text{O}}$	..	..	..	$0·750 - x$
$p_{\text{H}_2}$	..	..	..	$0·125 + x$
$p_{\text{CO}}$	..	..	..	$0·105 - x$
$p_{\text{CO}_2}$	..	..	..	$0·010 + x$
$p_{\text{N}_2}$	..	..	..	0·010
				1·000

The value of  $x$  may be deduced from the relationship

$$\begin{aligned} K &= 0·16 = \frac{p_{\text{CO}} \times p_{\text{H}_2\text{O}}}{p_{\text{CO}_2} \times p_{\text{H}_2}} \\ &= \frac{(0·105 - x)(0·750 - x)}{(0·010 + x)(0·125 + x)} \end{aligned}$$

which gives the value of 0·09899 atm. for  $x$ . The final partial pressure of carbon monoxide, therefore, is 0·006 atm.

On the removal of the steam by cooling, the partial pressure of the carbon monoxide rises to  $\frac{0·006}{0·349}$  atm. = 0·0172 atm., since the partial pressure of steam after reaction is  $0·750 - 0·099 = 0·651$  atm. and the partial pressure of the non-condensable gases, in consequence, 0·349 atm.

By similar reasoning the final composition of the gas is seen to be

Hydrogen	..	..	..	0·6418
Carbon monoxide	..	..	..	0·0172
Carbon dioxide	..	..	..	0·3123
Nitrogen	..	..	..	0·0287
				<hr/>
				1·0000

After removal of carbon dioxide this becomes, expressed in percentages—

Hydrogen	..	..	..	93·33
Carbon monoxide	..	..	..	2·50
Nitrogen	..	..	..	4·17
				<hr/>
				100·00

## (2) Griesheim-Elektron Process

A description will first be given of the principal patents on which the process is based.

In U.S.P. 229339/80, Tessié du Motay describes the production of hydrogen by passing water gas, freed from sulphur, over heated lime. The method is elaborated by the Chemische Fabrik Griesheim-Elektron in B.P. 2523/09, according to which, water gas and steam are passed over caustic or slaked lime at 500° C. in a suitable container which may be provided with stirring gear. The reaction is self-supporting and the chamber is cooled to below the temperature of the dissociation of calcium carbonate—preferably below 500° C. By the addition of 5 % iron powder the reaction is greatly accelerated. The lime is regenerated by subsequent calcination of the calcium carbonate. In a later patent, B.P. 13049/12, it is claimed that the lime may be advantageously used in the form of lumps, the action not being confined to the surface as might be expected. The material may thus be used in vertical towers and regenerated *in situ*. The same company, in D.R.P. 284816/14, describes

the manufacture of hydrogen by the action of steam under about 10 atms. pressure, on a mixture of lime and charcoal or lignite. With lime, a temperature of 600–800° C. is required, but by using baryta a lower temperature is possible. Among other patents may be mentioned B.P. 7147/13 (Soc. l'Air Liquide) which relates to the utilization of the carbon monoxide-rich fraction obtained in the separation of carbon monoxide from hydrogen by the Claude liquefaction process (cf. p. 170). This gas, which contains some hydrogen, is partially or wholly converted into hydrogen by the action of heated slaked lime as above, the product being returned to the water gas to be liquefied.

Bearing on this reaction there is a considerable amount of literature, a brief survey of which now follows.

Merz and Weith (*Ber.*, **13**, (1880), 718) describe a lecture experiment in which carbon monoxide is passed over heated calcium hydroxide just below a red heat. Hydrogen with only a small percentage of carbon monoxide is easily obtained.

The matter was further studied in Haber's laboratory by Engels (*Karlsruhe Dissertation*, 1911, "Über die Wasserstoff Gewinnung aus Kohlenoxyd und Kalkhydrat") who carried out extensive experiments on the reactions underlying the process. Carbon monoxide was passed over lime, the temperature, speed, and CO/H<sub>2</sub>O ratio being varied. Engels concludes that in the absence of a catalyst the conversion takes place essentially on the calcium hydroxide, although the water gas reaction plays a minor part. On the contrary, if 5 % reduced iron be present, the action takes place mainly in the gaseous phase. If pure lime be used the reaction velocity is too low below 500° C., while 540° C. should not be exceeded as the calcium hydroxide has a vapour pressure of 1 atmosphere at 547° C.; a greater steam concentration than that corresponding to the vapour tension of lime at the particular temperature is useless and, on account of the dilution of the reaction mixture, to be avoided. The reaction velocity is increased about 10 times by the addition of iron; thus with an 81/19 H<sub>2</sub>O/H<sub>2</sub> ratio, a gas flow of 12.5 litres carbon monoxide, measured at 20° C., per litre lime per hour,

gave at 500° C., a gas containing 0.4 % carbon monoxide in the absence of iron, while under the same conditions but using 5 % iron, a corresponding velocity of 138 litres per hour gave practically pure hydrogen (0.2 % carbon monoxide).

According to Vignon (*Bull. Soc. Chim.*, 9, (1911), 18), in treating water gas with lime no action takes place until 400° C., when hydrogen is formed together with some methane and ethylene. The proportion of hydrogen to hydrocarbons increases as the temperature is raised, pure hydrogen being formed at 600° C. Levi and Piva (*Ann. Chim. App.*, 1, (1914), 1; *J. Soc. Chem. Ind.*, (1914), 310) consider the action of carbon monoxide on calcium hydroxide to take place through the intermediate formation of formates and oxalates, and state that on heating sodium formate in an atmosphere of carbon monoxide, hydrogen with carbon dioxide and some methane is formed. In a later paper (*Chem. Soc. Abstracts*, (1916), ii., 525) the same investigators observe that the decomposition temperature of sodium formate is lowered from 375° C. to 260° C. by the presence of slaked lime. With pure lime, carbon monoxide gives rise to formates at 250–300° C. and to calcium carbonate and hydrogen above 300° C.

**Theory of the Griesheim-Elektron Process.**—It is instructive to calculate what is the lowest possible percentage of carbon monoxide which can be obtained with a given proportion of steam at say 500° C., below which temperature the reaction velocity is low.

Consider a gas of the percentage composition—

Hydrogen	..	..	..	50
Carbon monoxide	..	..	..	42
Carbon dioxide	..	..	..	4
Nitrogen	..	..	..	4
				100

to 100 volumes of which at 100° C., 200 volumes of steam are added.

Now, since the final volume of hydrogen is approximately equal to the original volume of the water gas, the carbon



monoxide being almost completely converted into hydrogen without change of volume, we have after cooling to  $100^{\circ}\text{C}.$ —

$$v_{\text{H}_2f} = c_{\text{H}_2i} + v_{\text{CO}_i} = 50 + 42 = 92$$

while

$$v_{\text{H}_2\text{O}_f} = 200 - v_{\text{CO}_i} = 200 - 42 = 158$$

where the suffixes  $i$  and  $f$  denote the initial and final volumes respectively.

Thus—

$$\frac{p_{\text{CO}}}{p_{\text{CO}_2}} = K \frac{p_{\text{H}_2}}{p_{\text{H}_2\text{O}}} = 0.16 \frac{92}{158} = 0.093$$

The value for the dissociation pressure of calcium carbonate as determined by Johnson (*J. Amer. Chem. Soc.*, **32**, (1910), 938) is 1 mm. at  $587^{\circ}\text{C}.$ , but taking for simplicity 1 mm. at the lower temperature of  $500^{\circ}\text{C}.$ ,

$$p_{\text{CO}} = 0.093 p_{\text{CO}_2} = 0.093 \text{ mm. approximately.}$$

Now, since the final volume of the reaction products is approximately  $92 + 158 + 4 = 254$  at a temperature of  $100^{\circ}\text{C}.$ , while after removal of the steam it falls to  $92 + 4 = 96$ , the pressure of carbon monoxide in the cooled gas after removal of the carbon dioxide, will be—

$$\frac{0.093 \times 254}{96} = 0.25 \text{ mm.}$$

or 0.032 %.

The hydrogen produced commercially by this process is stated to have the following percentage composition:—

Hydrogen .. .. .	97.5
Carbon monoxide .. ..	0.0-0.2
Methane .. .. .	0.3-0.5
Nitrogen .. .. .	1.5-2.0

The cost of production depends on the size of the installation, but for moderate plants in continuous operation the cost is stated to be  $2/2\frac{1}{2}$ – $2/9$  per 1000 ft.<sup>3</sup> (pre-war), while for large plants it falls to  $1/8$  (Lepsius, *Monit. Scient.*, (1912), 493). As the reaction is exothermic it is only necessary to supply heat at the commencement of the operation. The lime

container requires to be cooled and the waste heat may be utilized for the generation of the steam for the process. One advantage claimed is the comparatively low temperature at which the operation is conducted as compared with the Lane and allied processes, for instance, repairs being thus minimized.

The process does not appear to have been used on any considerable scale—the handling of the large amounts of lime presents some difficulty.

#### MANUFACTURE FROM WATER GAS BY LIQUEFACTION OF THE CARBON MONOXIDE

This purely physical method of separating hydrogen from water gas is in use on a fairly extensive scale and was the process installed by the Badische Co. in their first synthetic ammonia factory. It depends on the approximate separation of the carbon monoxide and nitrogen as liquid by cooling under pressure to about  $-200^{\circ}\text{C}$ . The general trend of the process may be seen from the following table:—

Gas .. .. .	Vapour pressure of liquid at $-200^{\circ}\text{C}$ .
Hydrogen .. .. .	(Above critical temperature, namely $-241.2^{\circ}\text{C}$ .)
Carbon monoxide ..	0.57 atm.
Nitrogen .. .. .	0.33 atm.

A brief resumé will first be given of the principal patents relating to this process.

Parkinson, in B.P. 4411/92, deals with the separation of the constituents of gases such as air and water gas by fractionation, etc. Some of the other early patents relating to the liquefaction of the permanent gases have a bearing on the separation of hydrogen from other gases, but the most important are those given below. According to B.P. 7205/11, of the Gesellschaft für Linde's Eismaschinen, A.G., the compressed hydrogen-carbon monoxide mixture is cooled by passing through a heat-interchanger, the cooling effect of which may be augmented by means of liquid air or nitrogen.

Partial liquefaction takes place under pressure and the two phases are then allowed to expand in separate streams into the above mentioned heat-interchanger in counter-current to the incoming gas. The hydrogen, before expansion, however, may pass through a second heat-interchanger in counter-current to the expanded hydrogen, whereby more carbon monoxide is deposited in a chamber connected to the first liquefaction chamber, the hydrogen being thus rendered purer.

A subsequent patent, B.P. 9260/11, deals with certain modifications: (1) a more thorough fractionation is effected by cooling either the mixed incoming gases or the hydrogen fraction (as in Fig. 16) before its expansion, with liquid air or nitrogen boiling under reduced pressure, a lower temperature being thus secured: (2) the hydrogen may be

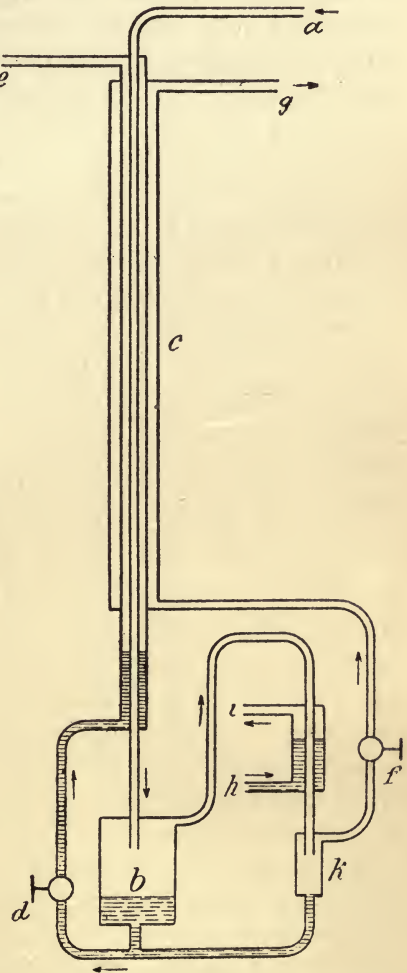

FIG. 16.—Linde's system for the separation of hydrogen from water gas by liquefaction of the carbon monoxide.

expanded either with or without the performance of external work, in the former case the hydrogen may be slightly heated by the incoming gases before they are cooled by the

evaporation of the liquid carbon monoxide fraction, in order to prevent blocking up by solidification on expansion; the cooling effect of the external work may be used to cool the hydrogen leaving the chamber in which separation of the carbon monoxide has taken place, further carbon monoxide being deposited: (3) the hydrogen may be led away in the compressed state, the extra cooling necessary being supplied by the liquid air boiling under reduced pressure.

A simplified apparatus, described by the Maschinenbau-Anstalt-Humboldt in F.P. 445883/12, differs from the above in that the compressed water gas, after traversing a heat-interchanger, passes through a coil immersed in evaporating carbon monoxide and then expands into a chamber where carbon monoxide is deposited. The hydrogen escapes directly through the heat-interchanger, while the carbon monoxide is siphoned off to the above mentioned evaporation chamber and after vaporizing enters the heat-interchanger. B.P. 7147/13 of the Soc. l'Air Liquide deals with a combination of the liquefaction process with the Griesheim-Elektron process (cf. p. 164) whereby the production of hydrogen per volume water gas is increased. The carbon monoxide-rich portion, after vaporization, is passed over heated slaked lime and the resulting gas, mainly hydrogen, added to the water gas entering the liquefaction system. An attempt is made by the Badische Co., in D.R.P. 285703/13, to avoid the necessity for supplementary cooling by liquid air, by the addition of excess of carbon monoxide or nitrogen, both of which gases show a positive Joule-Thomson effect. This may be accomplished by returning the more volatile portion of the carbon monoxide fraction, containing hydrogen, to the water gas-supply.

In B.P. 13160/14, Claude (Soc. l'Air Liquide) describes apparatus somewhat similar to that of Linde. The compressed water gas is divided into two portions which are cooled by passing through two independent auxiliary heat-interchangers AA (Fig. 17), traversed respectively by counter-currents of the expanded hydrogen and carbon monoxide. After re-union of the two streams of water gas, the carbon monoxide

fraction is deposited in a separation chamber  $B^1$ , the liquid and gaseous phases being then treated separately in the two portions, B and C (Fig. 18) of the heat-interchanger situated above  $B^1$ ; the hydrogen passes through both sections in vertical tubes. The lower part B contains, under atmospheric pressure, liquid carbon monoxide which is fed in from the separating chamber  $B^1$ . The liquid carbon monoxide passes

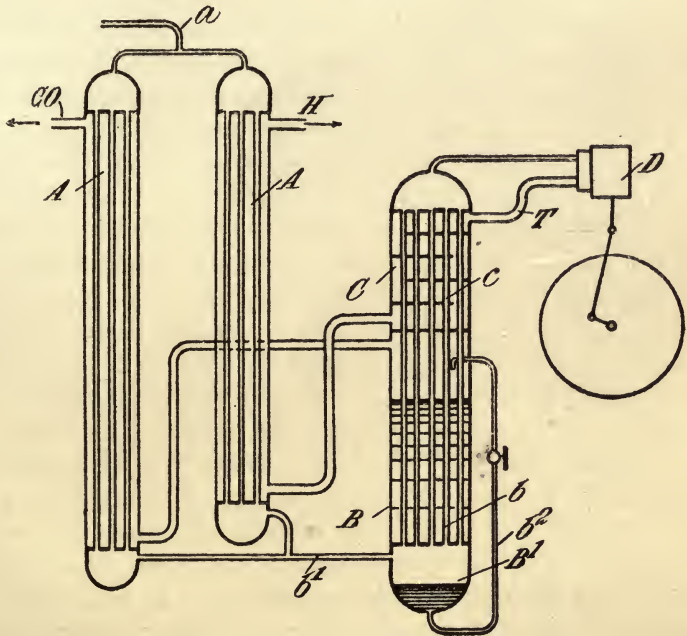

FIG. 17.—Claude fractionation system.

(1) through a coil  $S$  immersed in the liquid contained in the lower part of the heat-interchanger  $B$ , being cooled thereby; (2) through a coil  $S^1$  immersed in a small interchanger filled with the liquid released to atmospheric pressure from the same coil  $S^1$ , and (3) after this release of pressure into a tank  $E$  surrounding the hydrogen tubes in the upper part of section  $B$  of the interchanger, finally overflowing into the main bulk of liquid carbon monoxide below. The object of this rather complicated procedure is to utilize the lower

temperature of the carbon monoxide deposited in B<sup>1</sup> (in which carbon monoxide some hydrogen is retained on account of its separation under pressure) to further cool the hydrogen and so cause more complete deposition of the carbon monoxide therefrom. With this method of working, the hydrogen passes through tubes cooled by (1) liquid carbon monoxide evaporating under atmospheric pressure;

(2) liquid carbon monoxide containing some hydrogen also evaporating under atmospheric pressure; and (3) the gases in the upper part C of the interchanger. Here the hydrogen is still further cooled by passing to an engine D in which expansion takes place, the expanded gases being led back to the interchanger. The carbon monoxide deposited in the tubes falls back to the separation chamber B<sup>1</sup>. If desired the cooling effect may be increased by the expansion of supplementary compressed hydrogen.

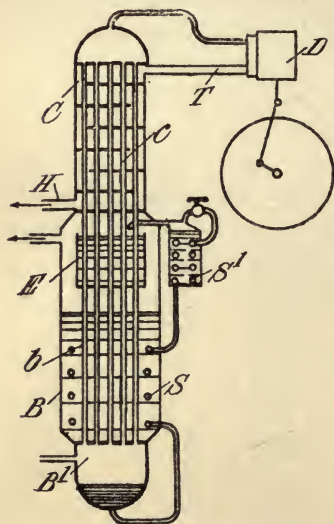

FIG. 18.—Claude fractionation system.

If high purity of the hydrogen is unnecessary, the simpler type of separator shown in Fig. 17 may be employed.

### The Linde-Frank-Caro Process

Several Linde-Frank-Caro plants have been installed on the Continent and one, of about 17,000 ft.<sup>3</sup> per hour capacity, by Messrs. Ardol, Ltd., in this country.

Water gas, which contains about 50 % hydrogen, the residue being mainly carbon monoxide with smaller quantities of carbon dioxide, nitrogen and methane, passes through a scrubber to a holder and is then compressed to about 25-50 atmospheres. Under this pressure it is freed from

carbon dioxide by washing with water—Bedford process (cf. also B.A.M.A.G. process, p. 161)—and subsequently with caustic soda. After being dried by refrigeration with an ammonia or carbon dioxide plant, the compressed gas enters the separator. Passing first through a heat-interchanger in counter-current to all the outgoing gases, the compressed gas traverses a coil immersed in liquid carbon monoxide boiling under atmospheric pressure. Here the greater part of the carbon monoxide is condensed and a little of the nitrogen. The liquid and gaseous phases are separated in a special vessel and the hydrogen, still containing some 5-6 % carbon monoxide and nitrogen, passes on to a tube system cooled to about  $-200^{\circ}$  C. by means of liquid air or nitrogen boiling under reduced pressure. The liquid carbon monoxide and nitrogen separated at this stage flow back to the main portion in the separation vessel from which the liquid passes through a valve to the vessel containing liquid carbon monoxide at atmospheric pressure, used to cool the compressed gases as mentioned above. By means of careful lagging the heat losses are made very small so that only relatively little liquid nitrogen is needed. The hydrogen leaves the apparatus through the heat-interchanger under the same pressure as that of entry, consequently little, if any, energy is required for its subsequent utilization for the manufacture of synthetic ammonia, the hydrogenation of oils, etc.

The arrangement is identical with that represented diagrammatically in Fig. 16 except that the hydrogen is carried back through the interchanger without release of pressure. After evaporation, the carbon monoxide fraction, which has a purity of 80-85 %, corresponding to a loss of about 15 % of the hydrogen, passes to a gas engine, the power generated being sufficient to drive the whole plant. The hydrogen fraction has obviously a very high degree of purity as regards sulphur and phosphorus compounds, heavy hydrocarbons, etc., and the following percentage composition is claimed :—

Hydrogen	..	..	..	97-97.5
Carbon monoxide	..	..	..	2-1.7
Nitrogen	..	..	..	1-0.8

The volume of hydrogen is about 40 % of the original water gas. This purity is sufficient for many purposes, but, if desired, further purification may be effected, see p. 207.

On account of the fractionation of the liquid air which may be produced in the separator itself, or in very large plants in a separate apparatus, nitrogen and oxygen may be obtained as by-products. The operations may be so regulated that the former is produced in the proportion required for combination with the hydrogen to form ammonia.

The following particulars are given by Sander (*Z. angew. Chem.*, (1912), 2401) for different sizes of plants :—

TABLE 22.  
LINDE-FRANK-CARO HYDROGEN PLANTS.

Hourly output (ft. <sup>3</sup> of hydrogen) ..	880	3500	17,700
Water gas used per hour (ft. <sup>3</sup> ) .. ..	2500	8800	44,000
Coke used per hour (lbs.) .. ..	110	350	1700
Cooling water used per hour (gallons) ..	500	1700	7000

Plants producing 3500 and 35,000 ft.<sup>3</sup> of hydrogen per hour are stated to cost about £13,000 and £80,000 respectively, while the cost of production of the hydrogen by this process is claimed to be about 3/- to 4/- per 1000 ft.<sup>3</sup> for medium-sized plants (all on pre-war basis). The labour required in working the plant is small on account of the continuous nature of the operations. One advantage of the process when used in connection with the hydrogenation of oils is the ease with which the residual impure hydrogen may be purified again. On the other hand repairs are somewhat heavy.

#### MANUFACTURE BY THE ACTION OF WATER OR STEAM ON IRON OR CARBON

**General.**—The processes falling under this heading are all capable of representation by the following equation :—

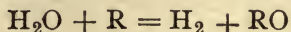

Generally speaking, R may be any substance, usually an element, which has the power of uniting with oxygen,



but in practice only iron and carbon find application for this purpose leaving out of consideration certain methods used for field purposes, *e.g.* the action on water of sodium or other active elements.

### Iron Oxide Processes. The Alternate Action of Steam and Reducing Gases on Heated Iron

At a red heat iron reacts with steam according to the following equation :—

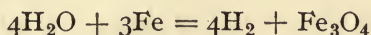

The action is reversible and the ratio of  $p_{\text{H}_2\text{O}}/p_{\text{H}_2}$  for different temperatures is given below, the equilibrium relations for the two stages of the reaction being separated (Chaudron, *Comptes Rend.*, **159**, (1914), 237). The values are taken from a smoothed curve.

SYSTEM Fe/FeO/H<sub>2</sub>/H<sub>2</sub>O.

Temperature °C. ..	400	500	600	700	800	850
$p_{\text{H}_2\text{O}}/p_{\text{H}_2}$ .. ..	0·15	0·23	0·33	0·46	0·61	0·70

SYSTEM FeO/Fe<sub>3</sub>O<sub>4</sub>/H<sub>2</sub>/H<sub>2</sub>O.

Temperature °C. ..	400	500	600	700	800	850
$p_{\text{H}_2\text{O}}/p_{\text{H}_2}$ .. ..	0·20	0·32	0·52	0·85	1·35	1·85

cf. also Wohler and Prager, *Z. Elektrochem.*, **23**, (1917), 199.

It is evident that reduction is favoured by increase of temperature. On passing a continuous current of steam or hydrogen over the iron or iron oxide heated to redness, the reaction proceeds to completion giving oxide or metal respectively.

This method of making hydrogen has long been recognized and we find patents dealing with the alternate action of steam and reducing gases on iron as early as 1861 (Jacob, B.P. 593/61 ; cf. also Baggs, B.P.s 2719/65 and 1471/73).

One of the first attempts at technical production by this method appears to have been made by Giffard in 1878, who employed a shaft filled with ore. Water gas was used without purification and for this reason, coupled with the irregular temperature distribution in the shaft type of plant, the life of the ore was very short.

The first patent of commercial importance is that of Lewes, B.P. 20752/90, according to which a retort containing iron turnings or moulded oxide, etc., is heated to bright redness by imbedding in a producer, the air producer gas from which is used in the reduction phase, the metal being then treated with steam. This procedure would obviously give rise to over-heating of the iron oxide. In a later patent, B.P. 4134/91, the iron oxide is disposed on pumice or mixed with asbestos, and semi-water gas is used for the reduction. A number of patents dealing with special forms of plant follow. An important point is touched on by the Dellwik-Fleischer Wassergas G.m.b.H., in B.P. 21479/08, which prescribes the addition of steam to the reducing gases to prevent the deposition of carbon; the reduction is arrested when only half the oxide is reduced. Burnt pyrites is used as reaction material. In B.P. 17591/09, Lane describes an arrangement of valves whereby more retorts may be reduced than oxidized at the same time, this being desirable by reason of the greater reaction velocity in the oxidation phase. The first portion of the hydrogen is diverted. Impurities, *e.g.* sulphur, are removed by occasionally burning out with air, and in a later patent, B.P. 11878/10, a method of purification of the gases from carbon dioxide, sulphuretted hydrogen, and sulphur dioxide, by washing under pressure is described. Proposals have been made to use molten iron, *e.g.* as in B.P. 23418/10 by Gerhartz. The use of roasted spathic iron ore as reaction material is claimed by Dieffenbach and Moldenhauer in D.R.P. 232347/10, while B.P. 6683/12 of the Badische Co. relates to the prevention of loss of activity through fusion of the surface of the iron, by using iron oxide which has been melted in oxygen; refractory oxides may be added. Dieffenbach and Moldenhauer in a further patent, B.P.

12051/12, propose to prevent deterioration by the use of alloys of iron with manganese, tungsten, titanium, etc. Mixtures of nitrogen and hydrogen may be obtained by passing air and steam over the iron, or, alternatively, pure nitrogen may be obtained by using air alone.

Among various patents describing means of avoiding fall in output may be mentioned B.P. 12117/12 by Messerschmitt, according to whom the effects of fusion of the iron oxide in producing obstruction are avoided by the use of a skeleton of compact iron, and B.P. 27735/12 (Badische Co.), where loss of activity is prevented by the use of spongy iron obtained by imbedding Swedish iron ore in carbon and heating from the outside. We come next to a series of patents by Messerschmitt. B.P.s 12242/12 and 12243/12 deal with special methods of construction of plant, the latter describing the annular type of ore container detailed later. According to B.P. 17690/13, the reduction of the oxide is effected by gases of high calorific power and the heating by gases of low calorific power, *e.g.* the spent reducing gases, fusion being thus avoided, while B.P. 17691/13 advocates the reduction of the charge by means of a partly burnt mixture of gas with air in insufficient quantity for complete combustion. Modifications in construction are prescribed in B.P.s 17692/13, in 18942/13 and in D.R.P. 291902/14. B.P. 18028/13 is concerned with the use of iron-manganese ores in order that lower temperatures may be employed, thus avoiding absorption of carbon, sulphur, etc. According to D.R.P. 291603/13, the iron is oxidized to the stage of ferrous oxide, giving hydrogen, and then further with air, giving nitrogen. Among numerous other patents may be mentioned B.P. 16893/14 by Dempster, according to whom leakage of gas from one part of the system to another is prevented by suitable water seals, and B.P. 12698/15 by Maxted and Ridsdale, where the deposition of carbon or the formation of carbide from the gases in the reducing phase is prevented by the presence of carbon dioxide to the extent of at least twice the volume of the carbon monoxide; contamination of the hydrogen in the subsequent treatment with steam is thus avoided.

This procedure is equivalent, of course, to the addition of steam as set forth in B.P. 21479/08, see p. 176. In B.P. 119591/18, Thorssell and Lunden propose to increase the active life of the reaction material by impregnating iron sponge with a solution of alkali hydrate or carbonate.

Of the modifications of this method of producing hydrogen which are now in extensive use may be mentioned the Lane, the Messerschmitt and the Internationale Wasserstoff A. G. (B.A.M.A.G.) processes.

**Lane Process.**—This process, or as modified by Dempster, Messrs. Humphrey and Glasgow and others, is the one most commonly adopted in this country for the production of hydrogen on a large scale. Calcined spathic iron ore, disposed in vertical cast-iron retorts, is alternately reduced by water gas and oxidized by steam.

From the equations

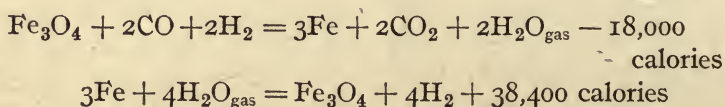

it will be seen that the reduction is endothermic while the oxidation is exothermic. As regards the reduction by a mixture of carbon monoxide and hydrogen, the interaction of the latter reducing agent absorbs a large amount of heat, while that of the former is very slightly exothermic; on this basis Jaubert effects economy in the fuel required for maintaining the reaction temperature by working at a lower temperature so that the carbon monoxide acts preferentially. This method of procedure (Lane-Jaubert process) has probably corresponding disadvantages in increasing the deposition of carbon in the reducing phase and consequently raising the carbon monoxide content of the hydrogen (see below).

The ore is contained in vertical cast-iron retorts about 9 inches internal diameter and nearly 10 ft. long, a plant generating 3500 ft.<sup>3</sup>/hr. having 36 such retorts, arranged in three groups each of 12 retorts (Fig. 19). Since the total

internal volume of such a set equals 159 ft.<sup>3</sup> the "space-velocity" is  $\frac{3500}{159}$  ft.<sup>3</sup> hydrogen/ft.<sup>3</sup>/hr. = 22 ft.<sup>3</sup> hydrogen/ft.<sup>3</sup>/hr. The ends of the retorts are flanged and closed by by

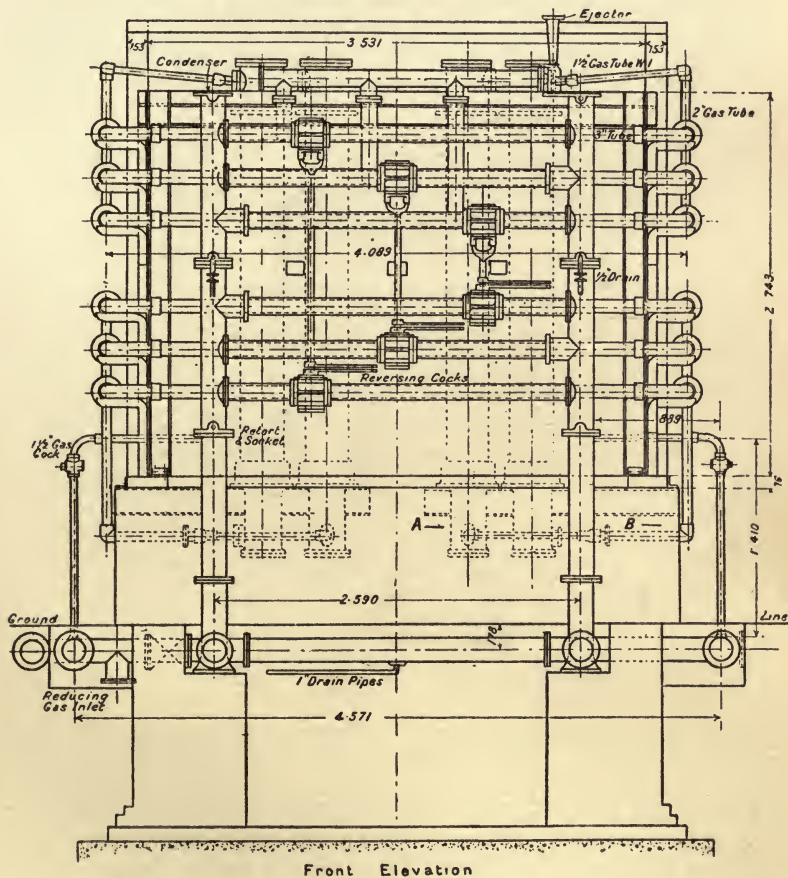

FIG. 19.—Lane Hydrogen Plant (*The Engineer*).

plates with asbestos joints. Heating of the retorts to 650–700° C. is effected either by means of a built-in producer or by the combustion of water gas which, of course, needs no purification.

The method of operation is as follows :—Two of the three

groups are supplied with water gas for 20 minutes, whereby reduction of the oxide takes place, and then treated with steam for 10 minutes, the reduction occupying more time than the oxidation. During the reduction phase the carbon monoxide and hydrogen of the water gas are only partly utilized and, consequently, the exit gases are used for heating the retorts, first passing through a condenser to remove the

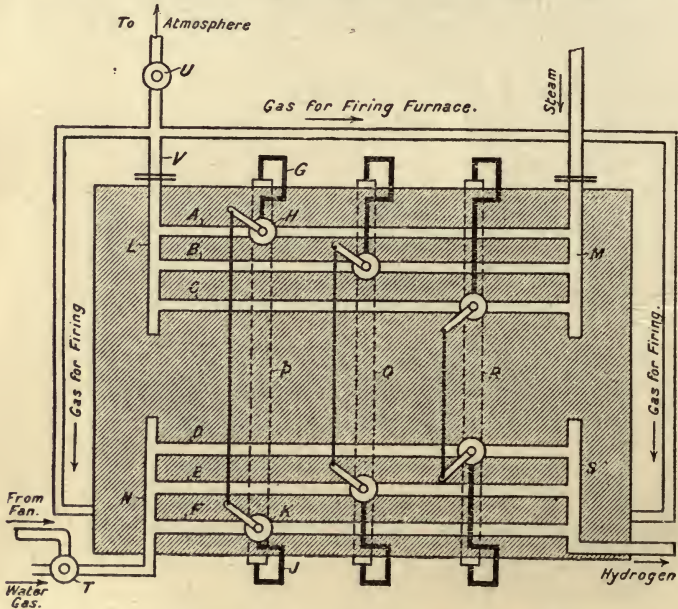

FIG. 20.—Diagram of the Lane Hydrogen Retort Furnace  
(The Engineer).

steam. When reduction is complete, the retorts contain water gas which, if passed into the hydrogen gas-holder, would introduce carbon monoxide; for this reason "scavenging" is resorted to, *i.e.* for a short time after admitting steam, the impure hydrogen is passed back into the water gas main and is thus not lost. Connection is then made to the hydrogen main. A convenient arrangement of change-over valves, as shown diagrammatically in Fig. 20, is employed to effect these operations. When changing from the oxidizing to the reducing phase the valve H is operated slightly in

advance of the valve K. The spent reducing gases, still containing some combustible gases, on leaving the retorts pass to condensers in which the bulk of the steam formed in the retorts is separated, and then are led to the combustion chamber.

It is important carefully to purify the water gas used in the reduction of the ore, as sulphur compounds exert a deleterious influence causing disintegration and loss of activity. The water gas passes from the generators through a heat-interchanger in counter-current to the steam entering the generator, through a water scrubber to a gas-holder from which it is drawn by an exhauster into a series of purifiers charged with bog iron ore to remove sulphur compounds, and then enters the retorts. Four purifiers form a set, three being in use at once, the gas passing the three in series, entering the foulest first. The thorough elimination of the sulphuretted hydrogen from the water gas has an important bearing on the life of the reaction material.

During the reduction phase there is some deposition of carbon arising from decomposition of carbon monoxide.

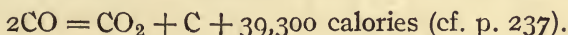

(For a fuller study of the complex equilibria of the system  $\text{Fe}/\text{FeO}/\text{Fe}_3\text{O}_4/\text{CO}/\text{CO}_2/\text{C}$ , reference should be made to Baur and Glässner, *Z. physik. Chem.*, **43**, (1903), 354; cf. also Carpenter and Smith, *Trans. Iron and Steel Inst.*, September, 1918.)

On passing steam, this carbon gives rise to carbon monoxide and carbon dioxide in the hydrogen. To minimize this effect and to remove accumulations of sulphur compounds, the retorts are periodically "burnt out" by blowing air through them.

Many attempts have been made, as has been mentioned in the patent synopsis, to prevent the deposition of carbon in the reducing phase. Thus, Maxted, of Gas Developments, Ltd., proposes to introduce sufficient carbon dioxide into the reducing gases to give a  $\text{CO}_2/\text{CO}$  ratio higher than that corresponding to the  $\text{CO}_2/\text{CO}/\text{C}$  equilibrium (cf. p. 237) by

using instead of ordinary water gas, a "converted" water gas (B.P. 12698/15; B.P. 125112/16, see p. 177). It should be pointed out that the equilibrium ratio of  $\text{CO}_2/\text{CO}$  is not that given on pp. 238-9 for any particular temperature, *e.g.*  $700^\circ\text{C}$ ., but varies with the actual joint partial pressure of carbon monoxide and carbon dioxide. By working from the value of  $K_t$ , which equals  $p_{\text{CO}_2}/p^2_{\text{CO}}$ , it is, however, easy to calculate the ratio for any particular condition.

On leaving the retorts the hydrogen passes through a scrubber, then through lime purifiers, where carbon dioxide, resulting from the oxidation of carbon monoxide in accordance with the water gas equilibrium, is removed, into a holder.

The temperature of the retorts is a matter of considerable importance, on account of its bearing on carbon deposition on the one hand, and on the life of the retorts on the other. The usual practice is to employ a temperature of about  $650^\circ\text{C}$ . The retorts are stated to last about 12 to 18 months and the ore about 6 months. Assuming the life of the retorts to be 12 months, the depreciation is equivalent to a charge of about 5*d.* per 1000 ft.<sup>3</sup> of hydrogen.

In good practice, 2-3 volumes of water gas are necessary for each volume of hydrogen produced.

A considerable number of plants have been erected in this country, in France and in Russia. The purity of the hydrogen may be fairly high with careful working, *e.g.* 99.5-99.75 %, the main impurities being carbon monoxide and a little (*e.g.* 0.25 %) nitrogen. Plants are made with capacities from 250-10,000 ft.<sup>3</sup>/hr. The cost of the hydrogen produced by this method is of the order of 3/- to 4/- per 1000 ft.<sup>3</sup> plus overhead charges (pre-war).

**The Messerschmitt Process.**—This process has come into considerable use in Germany and was largely adopted by the German War Department, which had some fifteen plants of 3500-20,000 ft.<sup>3</sup>/hr. capacity (Barnitz, *Met. and Chem. Eng.*, **15**, (1916), 494; *J. Soc. Chem. Ind.*, (1916), 1136).

It differs from the Lane process in having much larger units which are of annular form in order to minimize



variation of temperature. The latest type consists of an upright cylindrical shaft lined with firebrick into which shaft two concentric iron cylinders are built (Fig. 21). Of these, the inner one rests on the floor of the generator while

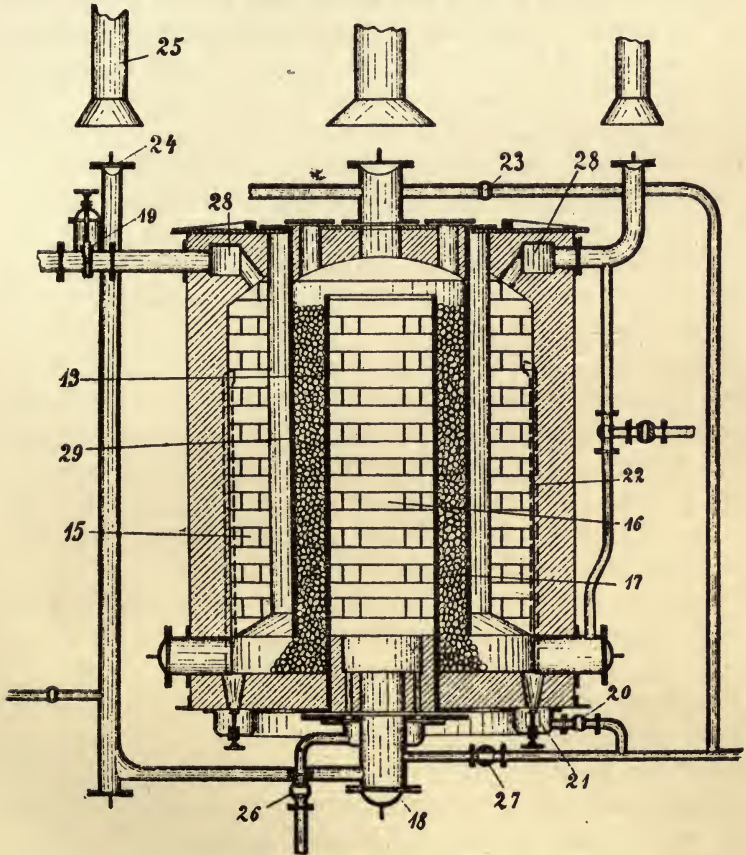

FIG. 21.—Messerschmitt Hydrogen System.

the other is raised slightly to afford room for the admission of the gases. The reaction material (iron ore or iron-manganese ore) is disposed in the annular space between the two cylinders. Chequer-work in the inner cylinder and between the outer cylinder and the furnace wall, serves to retain and regenerate the heat. A mixture of water gas

with insufficient air for complete combustion is burnt in the inner cylinder and the products of incomplete combustion pass downwards through the reaction mass in the annulus and upwards again outside the outer cylinder (secondary air being added at the last stage) and so out to the flue. After some 20 minutes, during which a temperature of 700–800° C. is maintained, the water gas and air are cut off and steam is passed into the generator from below. The issuing impure gases are allowed to escape for a few seconds into the flue; at this point the steam is diverted so as to enter at the top of the outer chamber, passing up through the reduced iron, the hydrogen being taken off at the top. Ten minutes suffices for the steaming operation, whereupon the cycle is repeated. The course of the combustion in the furnace may be reversed or the two directions may be alternated. In the Messerschmitt process the effect of carrying out the reduction with the partially burnt gases from the central heating chamber should be to prevent or minimize the deposition of carbon on the reaction material owing to the presence of carbon dioxide and its equivalent for this purpose, steam. The hydrogen is subjected to a final purification as in the Lane process.

Among the advantages claimed for the system are the ease of control of the working temperature and the avoidance of overheating. The purity of the gas is variously stated to be 98·5 to 99·2 %, while the cost, which varies with the size of the plant, is claimed to be as low as 2/- per 1000 ft.<sup>3</sup> inclusive of capital charges (pre-war). Little labour is demanded. When renewal is necessary the reaction mass is abstracted through Morton doors at the bottom. The apparatus is easily adapted to intermittent working should this be desired.

#### **Process of the Internationale Wasserstoff A.G.—**

This process differs little in principle from the other processes. In its earlier form the plant consisted of two vertical iron cylinders heated externally to 700–800° C. The process has been taken over recently by the B.A.M.A.G., which uses internally-heated firebrick shafts; the cycle consists of three

periods, namely, heating, reducing and steaming. Water gas of the highest possible calorific power is used for the reduction, the excess being subsequently burnt. As reaction mass, large lumps of burnt pyrites are used. Some carbon is deposited from the gases; the purity of the hydrogen may be 98–99 % with careful working, the carbon monoxide not exceeding 0·8 %.. For plants producing 60,000 ft.<sup>3</sup> per hour, the cost, inclusive of labour and repairs, is stated to be about  $\frac{3}{4}$  per 1000 ft.<sup>3</sup> (Sander, *J. Gasbeleucht.*, **58**, (1915), 637) (pre-war).

**Strache Process.**—An older process due to Strache employs three vertical iron cylinders set in firebrick, of which No. 1 is a water gas generator, No. 2 contains iron oxide and No. 3 is a regenerator. The steam is passed in the reverse direction, *i.e.* from 3 to 1 via 2.

With reference to all the above discontinuous processes, the general statement may be made that the hydrogen is liable to contain variable amounts of carbon monoxide, say 0·25 to 1·5 %, unless subjected to further purification.

### Dieffenbach and Moldenhauer Process

When steam is passed through heated carbon, a mixture of carbon monoxide, carbon dioxide and hydrogen is produced. In usual practice, *e.g.* in making water gas, the operation is conducted so as to give a high CO/CO<sub>2</sub> ratio; this is effected by working at a temperature such as 1000° C. While the conversion of the carbon monoxide of water gas into carbon dioxide may be realized by the B.A.M.A.G. process, proposals have been made, especially by Dieffenbach and Moldenhauer, to combine the two stages by conducting the actual gasification of the carbon at a relatively low temperature. This is accomplished by impregnation of the coke with a suitable catalyst, such as an alkaline salt, to increase the reaction velocity.

The idea is an attractive one; on the other hand, there is no record of any industrial success having been attained by such processes, neither are technical data of the process available. Such a process is unlikely to be of importance in

the production of pure hydrogen; the matter is, however, of sufficient interest to warrant a brief synopsis of the main patents.

According to Tessié du Motay and Maréchal (B.P. 2548/67) hydrogen is produced, together with carbon dioxide, by heating fuel with caustic soda or lime. B.P. 8426/92 by Krupp is similar. Steam is passed over carbonaceous matter mixed with hydrates, carbonates, etc., which limit the temperature of the operation, thus reducing the percentage of carbon monoxide. By passing over red-hot lime the carbon dioxide is removed; this lime, as also that used in the generating retorts, being subsequently regenerated by the passage of steam. The same principle is elaborated by Dieffenbach and Moldenhauer in B.P. 7718/10, according to which carbon is impregnated with chlorides, sulphates, sulphides, etc., and heated with steam when the reaction takes place at a low temperature, *e.g.* at 600° C., producing only a little carbon monoxide. Coal may be impregnated and then coked preparatory to being heated with steam. The operation may be carried out in externally-heated retorts, or oxygen may be added in small quantities to maintain the temperature. According to B.P. 7719/10, charcoal is impregnated with salts especially silicates, and treated with steam at 550–750° C. The carbon monoxide content of the hydrogen is claimed not to exceed a few tenths per cent. In B.P. 7720/10 it is stated that better results are obtained by impregnating crushed coal and briquetting the product, so counteracting the tendency of the activity to fall off owing to impregnation being only local. The same inventors, in B.P. 8734/10, advocate the addition of a considerable quantity of lime together with salts in order to take up the carbon dioxide and lower the carbon monoxide content (*cf.* the Griesheim-Elektron process). For example, coke is first impregnated with 10 % potassium carbonate solution, then mixed with 5 times its weight of lime and heated in steam at 550–750° C. The potassium carbonate limits the dissociation of the calcium carbonate by making the reaction possible at a lower temperature.

### Bergius Process

This interesting process depends on the action of liquid water on iron or carbon at temperatures in the neighbourhood of  $300^{\circ}\text{C}$ ., and consequently under pressures at least equal to the vapour pressure of water, the following values relating to the temperature region concerned :—

Temperature $^{\circ}\text{C}$ . ..	250	300	350
Vapour pressure (atms.) ..	39	89	167

Above  $365^{\circ}\text{C}$ ., *i.e.* the critical temperature of water, no liquid can be present.

If carbon is used, the reaction differs from that obtaining in a gas producer in that the conditions for carbon monoxide production are much less favourable at the lower temperature in question. When iron is employed, the low temperature has in like manner the effect of preventing attack by the water on the impurities in the iron. The principal patents relating to this process are given below.

According to D.R.P. 259030/11 of Bergius and Chemische Fabrik vorm. Moritz. Milch & Co., carbon is heated with water under high pressure to about  $300^{\circ}\text{C}$ . In an example cited, 100 kilos. coke, 200 kilos. water, and 1 kilo. thallium chloride are heated together to  $340^{\circ}\text{C}$ . The resulting hydrogen and carbon dioxide are blown off at intervals and the carbon dioxide absorbed by lime. B.P. 19002/12 by Bergius relates to the use of iron; hydrogen is generated by the action of liquid water at temperatures above  $100^{\circ}\text{C}$ . on iron or its lower oxide, preferably in the presence of electrolytes, *e.g.* ferrous chloride. Metallic couples may be formed by the presence of metals electropositive to iron, *e.g.* an iron-copper couple may be used. In one example iron shavings are treated with water at  $300^{\circ}\text{C}$ ., the pressure being kept at 150 atmospheres; while in another, sodium chloride and a plate of copper are added, the pressure is allowed to rise to 120 atmospheres and a temperature of  $250^{\circ}\text{C}$ . is employed. In an addition to this patent, namely, B.P. 19003/12, Bergius describes suitable plant for carrying out the operations. In its essentials the apparatus consists of a steel pressure

vessel fitted with a reflux condenser, dry hydrogen being thus obtained. D.R.P. 277501/13 describes a pressure vessel containing a central heating tube round which is arranged a series of reaction tubes, each of which may be brought in turn under a feed opening in the cover and by this means frequent removal of the main cover is avoided. A later patent, D.R.P. 286961/13, deals with the use of water in the form of steam at temperatures below 500° C. Electrolytes are preferably added as in the previous patents.

An experimental plant was erected at Hanover (*J. Soc. Chem. Ind.*, (1913), 462; *Z. angew. Chem.*, (1913), i., 517; *Z. für komp. und flüssige Gase*, (1915), 33) to test the Bergius process. The plant consisted of six vessels, each of about 1·6 ft.<sup>3</sup> capacity and capable of generating some 150 ft.<sup>3</sup> of hydrogen per hour. A charge of iron was used, contained in a vessel inserted from the bottom of the bomb and forming a lining in order to protect the bomb itself from attack. Some 90 % of the iron was oxidized in a period of about 4 hours. With carbon the action was rather slow. The carbon and sulphur in the iron are stated to be unattacked.

In the following table are to be found comparative rates of reaction as influenced by additions:—

Reactants.	Temperature °C.	Hydrogen generated per hour.
Iron + pure water .. ..	300	230 c.c.
„ + FeCl <sub>2</sub> .. ..	300	1390 c.c.
„ + FeCl <sub>3</sub> + Cu .. ..	300	1930 c.c.
„ + FeCl <sub>2</sub> + Cu .. ..	340	3450 c.c.

On leaving the reflux condenser with which each bomb was fitted, the hydrogen passed through a water separator to storage cylinders. The gases being passed through a spiral cooled in liquid air and the condensate examined, the following analysis, calculated for the original gas, was obtained:—

	%
Hydrogen .. ..	99·95
Carbon monoxide .. ..	0·001
Saturated hydrocarbons ..	0·04
Unsaturated hydrocarbons	0·01

By passage over charcoal at liquid air temperatures, a purity of 99.995 % could be obtained.

This process has certain attractive features—(1) the small floor space required; (2) its suitability for small plants, *e.g.* for field work, on account of the low initial cost and the discontinuous nature of the operations; (3) the fact that only direct fuel heating is required; (4) the production of compressed hydrogen and (5) the high degree of purity of the hydrogen produced. One would, however, expect repairs to be rather high in view of the intermittent character of the process necessitating very frequent breaking of large high pressure joints. The cost of hydrogen produced by this method is stated to be  $1/4\frac{1}{2}$  to  $1/11$  per 1000 ft.<sup>3</sup> (pre-war).

#### MANUFACTURE OF HYDROGEN BY THE DECOMPOSITION OF HYDROCARBONS

Under this heading may be described a number of processes all of which depend on the dissociation of hydrocarbons by the action of heat. Such dissociations may be attended either by evolution or absorption of heat. As an example of the first class, acetylene is typical—

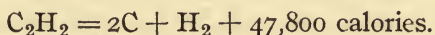

In consequence of the high heat evolution accompanied by no change in volume, the equilibrium conditions give almost complete decomposition except at very high temperatures. With exothermic hydrocarbons like methane, on the other hand, the degree of dissociation rises more or less rapidly as the temperature is raised. Thus, taking the case of methane, we have the following equilibrium conditions at different temperatures for the equation:—

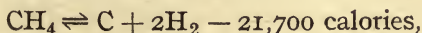

Temperature °C. . .	400	500	600	700	800	900	1000
Percentage of methane in the dissociated product. . .	86.2	62.5	31.7	11.1	4.4	2	1

the values at 900° and 1000° C. being obtained by extrapolation. The effect of temperature on the equilibrium  $\text{CH}_4 + \text{H}_2\text{O} \rightleftharpoons \text{CO} + 3\text{H}_2$  is treated on p. 240.

It must be borne in mind that methane is a very stable substance and that the equilibrium values are only slowly realized, particularly in the absence of catalysts, until temperatures in the region of 1000° C. are attained. Further, the influence of increased pressure is greatly to increase the stability, since the dissociation constant  $K$  equals

$$\frac{p_{\text{H}_2}^2}{p_{\text{CH}_4}}$$

The question of decomposing hydrocarbons has long received attention. In B.P. 1466/76, St. John describes the decomposition of coal gas hydrocarbons by passage through incandescent coke, while Stern, in B.P. 2787/80, leads naphtha vapour with steam over heated lime. Passing over a number of similar patents we come to the patents of Rincker and Wolter, F.P.s 391867/08 and 391868/08, according to which two coke-filled generators are heated to incandescence by the injection of air; tar, oil, or other suitable hydrocarbon is then introduced into one generator, undergoing transformation into hydrogen and carbon which is deposited in the generator. The generators are used alternately. A new line is taken by Machtolf in B.P. 14601/06. According to this patent, acetylene compressed to 4 to 6 atmospheres and mixed with oil gas, etc., is exploded electrically; hydrogen and lampblack are thus produced. In B.P. 15071/09, Lessing describes the production of hydrogen from coal gas by passing through a retort either empty or containing carbon, and heated to 1000–1300° C. In like manner, Nauss (B.P. 2298/10) passes coal gas over nickel at 250–300° C., whereby the carbon monoxide is converted into methane which is subsequently decomposed by treatment with coke at 1000–1200° C. According to Dieffenbach and Moldenhauer (D.R.P. 229406/09), hydrocarbons mixed with steam are heated and passed through a catalyst consisting of gauze of nickel, platinum, etc., disposed at



right angles to the current ; it is claimed that with such short exposure to the catalyst carbon dioxide is formed without the production of carbon monoxide. Oxygen may be added to maintain the temperature.

We will next consider a series of patents by Pictet, who in B.P. 24256/10 prescribes the passage of acetylene, alone or mixed with other hydrocarbons, under slight positive pressure, through a conduit maintained by cooling at about 500° C. If liquid hydrocarbons are added to the acetylene, the cooling may be effected by their evaporation. The heat evolved by the decomposition of the acetylene serves for the decomposition of the exothermic hydrocarbons added. According to B.P. 13397/11, petroleum is distilled into a long tube maintained at 1200–1350° C. by the supply of a certain number of calories, while in an addition to this patent, namely B.P. 14703/11, the admixture of steam with the petroleum is prescribed, so that the carbon is wholly or partially converted into carbon monoxide. B.P. 16373/11 relates to the addition of oxygen to the steam-petroleum mixture. The combination of the carbon and oxygen give sufficient heat to enable the reaction, represented by the following equation,

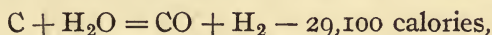

to proceed. The products in the two last patents are naturally mixtures of hydrogen and carbon monoxide.

Bosch, in D.R.P. 268291/11, describes the continuous decomposition of acetylene under pressure. B.P. 12978/13 (Badische Co.) relates to the passage of a mixture of hydrocarbons and steam over a catalyst consisting of a medium such as magnesia carrying 2–5 % nickel and maintained at a temperature of 800–1000° C. The carbon monoxide formed is subsequently removed. The B.A.M.A.G. (B.P. 2054/14) proposes to improve upon the usual practice, in the process for manufacturing hydrogen by cracking oils in a mass of heated coke, of spraying the oil on the coke, by effecting evaporation of the oil in an external chamber heated by the waste gases from the generator during the heating phase. Deposition of difficultly combustible carbon,

which may choke up the generator, is thus avoided. Ellis (U.S.P. 1092903/14) proposes to add lime to the fuel in order to flux the ash and prevent clinkering difficulties, while Brownlee and Uhlinger (B.P. 5098/15) describe a chamber which contains refractory material and is alternately heated with fuel gases and used to decompose hydrocarbons, the carbon formed being carried along with the hydrogen.

The principal processes which are known to be in actual operation are the Carbonium Gesellschaft, Rincker and Wolter, Oechelhauser, and B.A.M.A.G. (Bunte) processes.

**Carbonium Gesellschaft Process.**—In this process which is founded on the patent of Machtolf (see p. 190) acetylene is compressed to about 2 atmospheres and ignited electrically. Complete decomposition takes place with production of lampblack which is separated and forms a valuable pigment, about 60 lbs. per 1000 ft.<sup>3</sup> of hydrogen being formed. After passing through large scrubbers the hydrogen is obtained in an exceptionally pure state. The commercial success of the process depends on a market for the lampblack. A Zeppelin station at Friedrichshafen was supplied with hydrogen made in this way.

That the process is not free from danger is evidenced by the fact that this factory was largely destroyed by an explosion in 1910. The cost (pre-war) of the hydrogen by this process is stated by Sander to be about 4/- per 1000 ft.<sup>3</sup>

**Rincker and Wolter Process.**—This method of making hydrogen is due to two Dutch chemists, Rincker and Wolter, and has been developed by the B.A.M.A.G. and the Hollandsche Residugas-Maatschaapij. Two generators of the producer type are filled with coke. After heating the fuel beds to a high temperature by an air blast, the air producer gas from one generator being burnt by secondary air in the other, tar, oil, or other cheap hydrocarbon is sprayed in at the top of each generator for about a minute; decomposition is complete in about 20 minutes, the hydrogen escaping at the bottom. The "blow" is then repeated, this time in

the reverse direction. The carbon formed during the "make" is deposited on the coke and is burnt out in the next "blow" period. After traversing a system of scrubbers, coolers and driers, hydrogen of the following percentage composition is obtained (Ellis) :—

Hydrogen	..	..	96
Nitrogen	..	..	1·3
Carbon monoxide	..	..	2·7

By a further purification with heated soda-lime an analysis as below is obtained :—

			%
Hydrogen	..	..	98·4
Nitrogen	..	..	1·2
Carbon monoxide	..	..	0·4

A plant producing 3500 ft.<sup>3</sup>/hr. is stated to cost £550 exclusive of erecting expenses (Ellis), while the hydrogen costs 2/6-4/- per 1000 ft.<sup>3</sup> (pre-war). Plants are usually arranged to work normally for the production of illuminating gas, and for hydrogen manufacture when required. Portable plants on the Rincker and Wolter system have been used by the Russian and German Air Services. Two generators lined with firebrick are employed and are mounted on two railway trucks together with a turbo-blower and oil pump; the plants have a capacity of about 3500 ft.<sup>3</sup>/hr. Some 2-3 hours are required to start up; only coke and oil are used as raw materials, while two men are sufficient to operate the plant.

**Oechelhauser Process.**—This process, as to the commercial operation of which little has been published, depends on passing coal gas through vertical or horizontal retorts heated to 1200° C. and filled with coke. The lampblack formed is partly deposited on the coke and partly carried along with the hydrogen wherefrom it is filtered by wood fibre. After cooling and purification the gas consists of 80-84 % hydrogen. The following analysis indicates the nature of the changes induced (Lepsius, *Monit. Scient.*, (1912), 493) :—

	Coal gas.	Product of process.
	%	%
Heavy hydrocarbons, carbon dioxide, oxygen and nitrogen .. .. .	7·8	—
Carbon monoxide .. .. .	5·3	7·3
Methane .. .. .	24·7	6·9
Hydrogen .. .. .	59·6	80·7

The cost of production of this impure hydrogen is stated by Lepsius to be about the same as that of the original coal gas since there is an expansion, or about  $2/9-3/6$  per 1000 ft.<sup>3</sup> (pre-war).

On a modification of this method of making hydrogen is based the

**B.A.M.A.G. (Bunte) Process.**—This process, arising out of experiments by Bunte, is similar to the Oechelhauser process. Coal gas is freed from carbon dioxide and led over white-hot coke. After removing carbon monoxide by soda-lime the product is stated to be almost pure hydrogen, containing only a little nitrogen. The nitrogen content, however, will be not less than that originally present in the coal gas, making due allowance for the increase in volume. Crude hydrogen may be readily manufactured in this way in ordinary gas works, but purification by soda-lime is not attractive technically.

#### MANUFACTURE OF HYDROGEN BY ELECTROLYSIS

**General.**—Hydrogen is obtained electrolytically (1) by the electrolytic decomposition of dilute acids or alkalis as a special operation, or (2) as a by-product in certain electrochemical operations, *e.g.* the electrolysis of brine, with the production of caustic soda, the electrolysis of fused caustic soda in the manufacture of sodium, etc. Since, in many cases of the second class, the plant is not adapted to the collection and storage of all the gas evolved, the hydrogen is largely wasted; in view of the exceptional purity of the gas this is to be deplored.

It will be well at this stage to give some of the constants

to which all electrolytic processes for decomposing water may be referred.

96,470 coulombs (ampère-seconds) liberate  $\frac{1 \text{ gram-ion}}{\text{valency of ion}}$  grams of an ion.

1 ampère-hour liberates  $\frac{0.03732 \times \text{ionic weight}}{\text{valency of ion}}$  grams of an ion.

"	"	418.6 c.c. hydrogen	} at N.T.P.
"	"	209.3 c.c. oxygen	
"	"	441.6 c.c. hydrogen	} at 15° C. and 760 mm. pressure.
"	"	220.8 c.c. oxygen	
"	"	0.01560 ft. <sup>3</sup> hydrogen	} at 15° C. and 760 mm. pressure.
"	"	0.00780 ft. <sup>3</sup> oxygen	

1000 ft.<sup>3</sup> of hydrogen at 15° C. and 760 mm. pressure require 64,123 ampère-hours.

Decomposition voltage of water = 1.67 volts.

1.67 is the lowest voltage at which a permanent current may be passed through water and consequently determines the minimum possible energy expenditure, namely 107.1 K.W.H./1000 ft.<sup>3</sup> of hydrogen at 15° C. This efficiency cannot be attained in practice, however, as the resistance of the electrolyte necessitates an increase in the voltage to from 2 to 4 volts according to the electrolyte and the construction of the cell, thus raising the energy expenditure from 128 to 256 K.W.H./1000 ft.<sup>3</sup> of hydrogen.

It may be stated broadly that there are three main aims in the design of electrolytic cells: (1) to obtain the lowest possible resistance; (2) to prevent intermixing of the gases; (3) to avoid corrosion of the component parts of the cell. These problems have been solved, as far as the conflicting nature of the circumstances allows, as follows: (1) by using short columns of electrolytes having high electrical conductivity, the heat produced by the resistance of the electrolyte being conserved so as to maintain a temperature of, say, 70° C., and lower the resistance; (2) by the provision of partitions or diaphragms, porous or otherwise, between the electrodes, or by the provision of tortuous paths for the current in the electrolyte, also by precautions to maintain equal pressures in the two electrode compartments and (3) by suitable selection of materials and electrolytes. The conditions for (1) and (2) are somewhat in opposition; thus, diaphragms, etc., increase the resistance.

A brief survey of the important work on this subject will be given here in chronological order :—

As early as 1881, Barlow, in B.P. 1897/81, proposed the electrolysis of water, while d'Arsonval (*Elektrotech. Zeits.*, 12, (1891), 197) produced oxygen for physiological purposes on a large laboratory scale in 1885, using as electrolyte 30 % caustic potash solution with a linen diaphragm. Apparently the first large scale apparatus was constructed by Latchinoff (B.P. 15935/88). Either an acid or an alkaline electrolyte was used, with asbestos or parchment diaphragms. In another form of apparatus Latchinoff introduced the use of bipolar electrodes for the electrolysis of water. He also devised an apparatus for conducting the electrolysis under a pressure of 120 atmospheres. Renard took up the question from a military standpoint in 1888 (*Soc. de Physique*, (1890), 224; D.R.P. 58282/90) and used alkaline electrolytes, permitting the use of iron or steel electrodes. A further advantage of alkali is the absence of ozone, thus permitting the use of rubber for connections. An asbestos diaphragm was used, an E.M.F. of 3 volts being required. Inter-connected hydraulic seals were employed to equalize the pressure in the anode and cathode compartments. In 1892 a new principle was introduced by Garuti (B.P. 16588/92) in the use of a metal partition to avoid the disadvantages of high resistance and frequent renewals associated with porous diaphragms. The metal diaphragm does not reach to the bottom of the cell and the E.M.F. is kept below that at which the diaphragm will act as a bipolar electrode, say roughly about 3 volts. The apparatus is submerged in the electrolyte to prevent mixing of the gases. A modification of this idea is embodied in the patent of Siemens and Obach (B.P. 11973/93) in which the use of wire gauze diaphragms is proposed. Garuti and Pompili, in B.P. 23663/96, also try to lower the resistance by the use of diaphragms perforated in the lower parts. In 1899 an important advance was made by Schmidt who, in D.R.P. 111131/99, revived the idea of bipolar electrodes in combination with asbestos diaphragms in a practical way, the plant taking the form of a filter press,

in which the respective gases were led away by channels similar to those in filter-press practice. A noteworthy economy in floor space is thus effected. Schoop, in Austrian Patent 1285/1900, describes an apparatus which dispenses with a continuous diaphragm, replacing this by a collecting bell of glass or clay round each electrode. We find another patent by Garuti and Pompili, B.P. 12950/1900, where soldering is avoided by a special method of construction of the iron cells. The cells and diaphragms are prolonged below the electrodes. A later patent, B.P. 2820/02, relates to covering the perforations in the diaphragms with gauze, while in B.P. 27249/03, the same inventors describe apparatus for purification of the gases by passing them over heated platinum wire. In B.P. 17981/06, the Elektrizitäts Aktien Gesellschaft, vorm. Schuckert & Co. substitutes for the usual diaphragm an insulated bell disposed over one electrode, the cell forming the other electrode; in later patents, B.P.s 3000 and 3000A/07, two bells are used, each in electrical connection with its corresponding electrode and separated from the other by a screen of insulating material which projects well below the bells. Cowper-Coles, in B.P. 14285/07, dispenses with diaphragms and uses tongue-shaped projections (pointing downwards) on the electrodes as guides to the gases, while B.P. 24716/09 by Eycken, Leroy and Moritz deals with various precautions against mixing, especially when the gases are used under considerable pressure, in an apparatus of the filter-press type, the outlets being controlled by floats. In B.P.s 27264/10 and 21600/11, Knowles describes a catalytic purifier with heat regeneration and with water seals supplied by the water produced in the purifier. Electrolytic plants of the filter-press type are described by the Soc. Anon. l'Oxyhydrique Française and Levin in B.P.s 18818/13 and 3654/14 respectively. The recent patents on this subject are very numerous; it will perhaps suffice to mention the following: U.S.P. 1086804/14 by Burdett, D.R.P. 275515/14 by Maschinenfabrik Oerlikon, B.P. 101598/16 by Churchill and Geeraerd, and U.S.P.s 1239530/17 and 1256067/18 by

Schrifer, as examples of patents which have been developed commercially.

### Principal Electrolytic Processes used in Practice

The best known processes for the electrolytic decomposition of water are the Schuckert, Schmidt (Oerlikon), Garuti, Schoop, Churchill, International Oxygen Co., Schrifer and Burdett systems. It may be mentioned that electrolysis, at any rate in the past, has been used for the production of oxygen rather than hydrogen except as regards hydrogen for military purposes.

**Schuckert Process.**—In the Schuckert apparatus each cell usually takes 600 ampères. The electrodes are of iron and are covered with iron bells insulated from the electrodes and separated by a sheet of insulating material. As electrolyte a 20 % caustic soda solution is used. In order to minimize the resistance, the temperature is allowed to rise to 60–70° C. by packing round with sand, when 2·8–3 volts are required. Some corrosion of the electrodes takes place necessitating occasional renewals. For a plant producing some 10,000 ft.<sup>3</sup> of hydrogen per day, the energy expenditure, according to Lepsius (*Monit. Scient.*, (1912), 493), costs  $\frac{2}{3}$  to  $\frac{11}{3}$  per 1000 ft.<sup>3</sup> hydrogen plus 500 ft.<sup>3</sup> oxygen, while the total cost (not including compression) is 6/- to  $\frac{15}{3}$  per 1000 ft.<sup>3</sup> hydrogen plus 500 ft.<sup>3</sup> oxygen, when electric energy costs 0·1175*d.* to 0·59*d.* per K.W.H. By calculation from the above figures, 1000 ft.<sup>3</sup> hydrogen plus 500 ft.<sup>3</sup> oxygen require 227 K.W.H. According to Blum (*Metall. and Chem. Eng.*, (1911), 157), 275 K.W.H. are required.

This process is stated to be expensive and demands a large floor space, but gives very pure gases. The purity of the hydrogen leaving the cells is about 99 %, that of the oxygen about 97 %. The gases pass through scrubbers and then through catalytic purifiers.

A Schuckert plant was installed many years ago by Heræus of Hanau; there are plants also at Kehl am Rhein, at Metz, at the Wolverhampton works of the British Oxygen Co. and several plants in the United States.



**Schmidt Process.**—Schmidt's multiple cell takes the form of a filter-press with, for example, 40 bipolar electrodes in series. The electrodes are separated and insulated by asbestos diaphragms, reinforced at the edges with rubber. By means of passages similar to those in a filter-press, the hydrogen and oxygen respectively are led to the two sides and pass to chambers where the spray is separated and caused to flow back to the bottom of the cells. The gases may be taken off under a pressure of some 3 lbs. per in.<sup>2</sup>, or even up to 35 lbs. pressure, this being advantageous for long pipe lines. This plant is very compact and free from complicated gas and current connections. The electrolyte is a 10% solution of potassium carbonate or potassium hydrate. An E.M.F. of about 2.3 volts per cell is required at 60° C. According to Lorenz the current efficiency is 86%. Energy required per 1000 ft.<sup>3</sup> hydrogen plus 500 ft.<sup>3</sup> oxygen is about 170 K.W.H. according to Dammer; at 0.25d. per K.W.H. the cost for current is 3/6. Purification is effected by passing the gases over platinized asbestos at 100° C. Traces of carbon monoxide, derived from the rubber of the joints, are found in the oxygen. The purity of the hydrogen is 99%, that of the oxygen, 97%. A Schmidt plant was installed by the Swedish Navy.

The manufacture of the Schmidt cell was taken over by the Oerlikon Co., who installed a plant at the Farnborough Air Station, cf. p. 232. Similar apparatus is made by the International Oxygen Co., by Schriver and Co., and by other firms (see below, p. 200).

**Garuti Process.**—The Garuti cell has an iron diaphragm which is insulated from and projects below the electrodes, not functioning as a bipolar electrode so long as the voltage does not exceed twice the decomposition voltage of water or, say roughly, 3 volts. The absence of a porous diaphragm ensures a low resistance, while to decrease this still further, the diaphragms are perforated opposite to the centres of the electrodes, the holes being covered with gauze. A number of narrow cells are arranged together and submerged in a tank of electrolyte, a hydraulic seal being used to prevent

increase of pressure and mixing. As electrolyte, 26 % caustic potash solution is used. The gases are purified by passing over heated platinum wire; the purity attained is 98–99 % for the hydrogen, 97 % for the oxygen. E.M.F. required is about 2.5 volts, and the current efficiency about 96 % (Buffa). Electrical energy per 1000 ft.<sup>3</sup> hydrogen plus 500 ft.<sup>3</sup> oxygen is therefore 167 K.W.H., and cost of this at 0.25*d.* is 3/6. At 0.5*d.* per K.W.H., the cost per 1000 ft.<sup>3</sup> hydrogen plus 500 ft.<sup>3</sup> oxygen is stated to be about 9/- uncompressed.

Garuti plants have been installed in Rome, Tivoli, Terni, Lucerne, Monthard, and by the American Oxhydric Co., Milwaukee, Wis.

**Schoop Process.**—The Schoop process employs no diaphragm, but each of the long narrow tubular electrodes is surrounded by a collecting tube of glass or clay. Two anodes and two cathodes are mounted in each cylindrical cell. Using iron and an alkaline electrolyte, the voltage is about 2.25 volts, or if lead electrodes and dilute sulphuric acid are used, 3.6 volts. A high degree of purity is claimed for the gases, namely, hydrogen 97.5 %, oxygen 99 %.

With an acid electrolyte, which is apparently most commonly used, the electrical energy per 1000 ft.<sup>3</sup> hydrogen plus 500 ft.<sup>3</sup> oxygen for a voltage of 3.6 and a current efficiency of 100 %, would be 230 K.W.H., costing 4/10 for power at 0.25*d.*/K.W.H.

With an alkaline electrolyte and a voltage of 2.25, the power would be 144 K.W.H., the cost of which at 0.25*d.*/K.W.H. would be 3/-; the cost of the plant is higher in this case.

Plants have been installed at Kalk am Rhein and elsewhere.

**International Oxygen Co.'s Processes.**—The International Oxygen Co., of Newark, N.J., has two well-tried systems:—

(1) *Bipolar Filter-press Type.*—This is very similar to that of Schmidt; the large cells use a current of 400 ampères at a voltage of 2, a set of 60 electrodes running on 120 volts.

By using electrodes of commercially pure iron, nickel-plated on the anode side, the over-voltage is minimized. The energy is guaranteed not to exceed 127 K.W.H. per 1000 ft.<sup>3</sup> hydrogen plus 500 ft.<sup>3</sup> oxygen (measured at 15° C. and 760 mm.), with an electrolyte of 29 % caustic potash solution. This corresponds to a cost of 2/8 for current at 0.25d./K.W.H. As electrolyte, 14.5 % caustic soda solution may also be used. The purity of the hydrogen is stated to be 99.5 % and that of the oxygen 99 % on leaving the generators. The usual purifying and safety devices are employed.

(2) *Unit Cell Type*.—Enclosed oval cells are used with hydraulic seals for the cover and diaphragm, the latter being of asbestos. The tank itself forms the cathode, and an alkaline electrolyte is used. Energy consumption and purity of the gases are very similar to those relating to (1).

**Other Processes**.—Apparatus of the filter-press type is constructed by T. Schriyer and Co., Harrison, N.J., the performance of the plant is very similar to that described above for the International Oxygen Co. type (1).

The Churchill apparatus consists of narrow cells, the walls of which form the electrodes. No diaphragm is employed and intermixing of the gases is prevented by the provision of a series of glass or earthenware vanes arranged close to the electrode walls at an angle of about 45°, pointing downwards. The electrodes may be provided with vertical grooves to allow of the escape of the gases past the vanes. Owing to the absence of a diaphragm, the cell has a low resistance, and works at 2.3 volts. The energy requirements are about 155 K.W.H. per 1000 ft.<sup>3</sup> hydrogen plus 500 ft.<sup>3</sup> oxygen.

The Burdett plant has a number of electrodes in a tank, and the gases are taken off by means of bells divided into compartments by asbestos diaphragms.

In the above processes an addition of distilled water is made daily to compensate for that decomposed; about 4 $\frac{3}{4}$  gallons are required per 1000 ft.<sup>3</sup> of hydrogen neglecting evaporation. With alkaline electrolytes, absorption of carbon dioxide is largely prevented by the layer of water vapour on the surface when warm, or a layer of oil may be

used. Those systems employing light gauge electrodes, as the Garuti and Schuckert types, are liable to corrosion of the anodes at high current densities possibly due to the presence of chlorides or sulphates in the alkali. Such corrosion increases the resistance, while iron may be deposited on the cathode and cause short-circuiting.

It may be stated in general that the production of hydrogen by the electrolytic decomposition of water is expensive compared with other processes unless a very cheap source of energy is available; further, a very large floor space is required. The purity of the gases, after passing over a heated catalyst, is very high (cf. p. 213), and provided that due precautions are taken against intermixing, the process is safe and requires little attention. The prevention of mixing is very important when the gases are compressed, and several cylinder explosions have been traced to neglect in this particular (cf. also p. 39 *et seq.*). Injury to the diaphragm, blockage in the system, excess voltage on cells of the Garuti type, or too great current density, may cause such mixing.

The question of automatic apparatus for the detection and estimation of oxygen in hydrogen or vice versa is discussed on p. 33.

**Danger Limits as regards Intermixing in Electrolytic Hydrogen and Oxygen.**—The inflammability of mixtures of hydrogen and oxygen depends to a considerable extent on the mode of ignition, but the limits may be taken as 5.3 % oxygen and 5.5 % hydrogen in hydrogen and oxygen respectively (Fischer and Wolf, *Ber.*, **44**, (1911), 2956). According to Burrell and Gauger (*loc. cit.*, p. 40) the effect on the explosive limits of increased pressure up to 100 atmospheres is very small (cf. also p. 40).

### Hydrogen as a By-Product

Hydrogen is produced in large quantities as a waste product in certain electrochemical industries, *e.g.* in the Castner-Kellner and other processes for the manufacture of caustic soda by the electrolysis of brine. In the electrolysis,

a volume of 7230 ft.<sup>3</sup> of hydrogen at 15° C. is theoretically produced per ton of sodium chloride electrolysed. The Griesheim-Elektron works at Bitterfeld and Rheinfelden produced, according to Lepsius (1911), some 250,000,000 ft.<sup>3</sup>, *i.e.* about 600 tons, of hydrogen per annum, or 700,000 ft.<sup>3</sup> per diem, enough to inflate a dirigible balloon of moderate size. The purity of the hydrogen is 90-97 %. If ingress of air and chlorine be prevented, the hydrogen is, of course, of a high degree of purity.

On the advent of the Zeppelin in 1898 the gas was collected, hydrogen from this source becoming a commercial article. Hydrogen in a compressed state may now be obtained in England from the Castner-Kellner Co., whose daily production is some 500,000 ft.<sup>3</sup>, but before the war, at any rate, the bulk of the gas was wasted. Some of the hydrogen has been used by this firm for the production of pure hydrochloric acid for analytical purposes, etc., by direct combustion with the chlorine simultaneously liberated. This may be effected either by actual combustion or by combination in the presence of a catalyst, *e.g.* charcoal. Special precautions are necessary to prevent intermixing of the gases outside the combustion chamber.

#### OTHER PROCESSES FOR THE MANUFACTURE OF HYDROGEN

Before leaving the manufacture of hydrogen by methods suitable for use in stationary plants, it will be well to consider briefly a few patents, etc., which do not fall under the preceding general headings and which, although in most cases of little commercial importance, are mentioned for the sake of completeness. Some of the methods are also of interest in connection with field operations (*vide infra*).

**By the Action of Acids or Alkalis on Metals.**—The use of the action of acids on iron, zinc, etc., has been proposed from time to time, the expense of the processes being, in general, only tolerable where valuable by-products are secured.

In B.P.s 16277/96 and 15509/07, Pratis and Marengo describe apparatus for the generation of hydrogen from sulphuric acid and iron. Carulla, in B.P. 23702/08, proposes to absorb the hydrochloric acid from salt cake manufacture, by means of towers packed with iron scrap, the ferrous chloride liquor being worked up for iron oxide. In like manner Barton (B.P. 28534/10) suggests the interaction of zinc and sulphuric acid, the zinc sulphate solution being used to produce zinc carbonate for use as a pigment and filler, while Eastwick (B.P. 10228/11) uses the acid-zinc generator as a battery. B.P. 107807/16, by Becquefort and Deguide, relates to the utilization of sodium bisulphate by treatment with iron scrap. Another patent, B.P. 25891/11, by the Chemische Fabrik von Heyden, A.G., deals with the production of hydrogen by the action of ammonia on alloys of the alkali metals in a finely divided state. Further details referring to such methods will be found under Field Processes in the following section.

**Separation of Hydrogen from Water Gas and the like by Physical Methods.**—The only process of technical importance coming under this category is the Linde-Frank-Caro process, which has been already described.

Among other suggested processes may be mentioned that proposed by d'Arsonval (*Ann. Chim. et Phys.*, [7], 26, (1902), 446), based on the experiments of Dewar, who showed that coal gas could be freed from hydrocarbons by cooling to a suitable temperature with liquid air. Mazza, in B.P. 12194/02, and Elworthy, in B.P. 10581/06, propose to effect a preliminary separation of hydrogen and carbon monoxide (water gas) by centrifugal action, final purification of the two fractions being carried out according to Elworthy by chemical means, e.g. by cuprous chloride and caustic soda (cf. also B.P. 17946/05 by Clamond).

Several other patents deal with diffusion methods. Thus, in B.P. 22340/91, Pullman and Elworthy describe the production of a mixture of hydrogen and carbon dioxide by passing excess superheated steam over red-hot coke and subsequent separation of the gases by diffusion through

diaphragms of plaster of Paris or porous earthenware. Jouve and Gautier, in F.P. 372045/06, deal with a similar separation of the constituents of water gas by means of unglazed earthenware; it is stated that the percentage of carbon monoxide is reduced from 25 % to 4.4 % by a single passage. Cf. also Nussow, D.R.P. 295463/13, where liquid (*e.g.* water) or solid diaphragms are used. Snelling, in U.S.P. 1174631/16, in the separation of carbon monoxide from hydrogen uses a septum of porous earthenware or alundun, with a thin coating of platinum or palladium, heated to above 800° C. The operation is preferably conducted under pressure.

**Through the Intermediary of Formates.**—A number of patents relate to the production of hydrogen by the decomposition of formates, prepared from producer gas and the like. Thus, Feldkamp, in B.P. 22225/05, prescribes the production of formates from producer gas by the action of alkali solutions (*cf.* pp. 248, 316), and subsequent heating of such formates with production of oxalates and hydrogen. Similarly the Badische Co., in B.P. 30073/13, and Weise and Rieche, in U.S.P. 1098139/14, deal with the production of formates, using *e.g.* 20 % caustic soda liquor heated under pressure, with subsequent decomposition of the formate, either in the presence or absence of the residual nitrogen; in this way (1) a mixture of nitrogen and hydrogen (*see* p. 207) or (2) hydrogen is obtained.

**Miscellaneous Methods.**—In B.P. 2080/81, Hélouis describes a process whereby carbon monoxide is removed from water gas by passing over calcium sulphate heated to redness:—

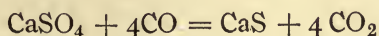

the carbon dioxide being absorbed by sodium carbonate solution.

Hutin, in B.P. 23370/94, covers an alloy of sodium and a heavy metal with a layer of concentrated sodium hydrate solution, the water content of which is maintained by supplying with steam above. A too violent reaction is thus avoided.

According to Lahousse, in F.P. 361866/05, steam is decomposed by passage over red-hot barium sulphide, which is subsequently regenerated by the reduction of the resulting barium sulphate with producer gas or coal.

The Nitrogen Co., N.Y., in B.P. 17666/11, prescribes the production of hydrogen by the action of molten zinc, antimony, tin, etc., at a red heat on steam. The metal is regenerated by passing the oxide into a solvent where it comes into contact with carbon or other reducing agent. According to Kendall, in B.P. 26896/12, a mixture of sodium chloride or potassium chloride with molybdenum is heated and treated with steam. Hydrogen, hydrochloric acid and alkali molybdate are produced. The molybdenum is regenerated by reduction of the molybdate with coke when carbon monoxide and sodium or potassium vapour are formed leaving metallic molybdenum. Tungsten may be used in like manner.

Teissier and Chaillaux, in F.P. 447688/12, propose to manufacture hydrogen and oxygen as follows: Barium sulphate is first heated to a red heat with manganous oxide when reaction (1) takes place. On raising the temperature to a white heat reaction (2) occurs, and on treating with steam under pressure, reaction (3) results, giving the original mixture again :—

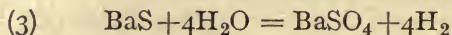
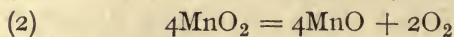
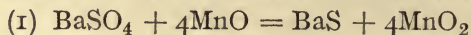

Hooton (B.P. 18007/14) proposes the treatment of iron pyrites with steam, whereby the ore is left almost free from sulphur while a mixture of hydrogen, sulphuretted hydrogen and sulphur dioxide is produced. By interaction of the sulphuretted hydrogen and sulphur dioxide in the presence of bog iron ore, sulphur is deposited, any excess of sulphur dioxide being removed by alkali.

Siemens and Halske, in D.R.P. 220486/10, describe a process of treating calcium carbide with steam at a high



temperature, whereby hydrogen is liberated as represented in the following equation :—

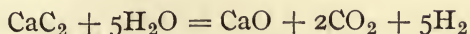

The carbon dioxide is removed by the lime resulting from a previous operation, and a high degree of purity of the hydrogen is claimed.

### Production of a Mixture of Nitrogen and Hydrogen for use in Synthetic Ammonia Manufacture

Reference has just been made (p. 205) to the production from producer gas of a mixture of nitrogen and hydrogen. There are a number of industrial applications, *e.g.* the synthesis of ammonia and the filling of electric lamps, in which a mixture of nitrogen and hydrogen is required, and occasionally it may be convenient to produce the mixture in a single operation. Since in the B.A.M.A.G. continuous catalytic hydrogen process, any nitrogen present in the water gas persists in the hydrogen produced, it is obviously a simple matter by using a controlled semi-water gas instead of water gas to produce a nitrogen-hydrogen mixture of any desired composition. Similarly in the Lane or Messerschmitt process, instead of steam, as in the usual method of operation, a suitable mixture of air and steam may be passed over the reduced iron (cf. Dieffenbach and Moldenhauer, B.P. 12051/12, p. 177). According to Messerschmitt, D.R.P. 291603/13, if steam is passed first and air is substituted when oxidation is partly effected, a more complete oxidation of the iron results. As described in U.S.P. 1123394/15, Scholl obtains a mixture of nitrogen and hydrogen suitable for lamp filling by passing a correctly proportioned mixture of gaseous ammonia and air over heated catalytic material (cf. p. 113).

#### METHODS OF FINAL PURIFICATION OF HYDROGEN

Certain methods of removal of foreign constituents generally present only in small quantities, not having been

described previously under the various methods of manufacture, will be given under this heading.

### Purification from Carbon Monoxide

The elimination of carbon monoxide from admixtures with hydrogen demands special treatment as the ready oxidation of the hydrogen itself precludes the application of such methods as the simple treatment with red-hot copper oxide used for nitrogen. Generally speaking, the high pressure methods described are only economical in connection with the production of synthetic ammonia.

(1a) *By Soda-Lime.*—In B.P. 10164/89 Crookes and Ricarde-Seaver deal with the removal of carbon monoxide from water gas by soda-lime at a red heat. At this temperature carbonate is formed but the reaction may be carried out more advantageously at a lower temperature, e.g. 180° C., with the production of formate, the absorption of carbon monoxide being facilitated by the use of pressure.

(1b) *By Caustic Soda Solution.*—B.P. 1759/12, by the Badische Co., relates to the removal of the last traces of carbon monoxide from hydrogen, containing, say 1 %, by passing through a solution of caustic soda at a temperature of 240–260° C. under a pressure of from 50 to 200 atmospheres. The reaction is, of course, the same as that occurring with soda-lime. The resulting sodium formate is a valuable by-product, cf. applications of carbon monoxide, p. 248.

(2) *By Cuprous Chloride Solution.*—Huntingdon, in B.P. 15310/84, deals with the removal of carbon monoxide from producer gas by the action of ammoniacal cuprous chloride solution under pressure, the copper solution being freed from gas by subjecting to a vacuum. Cf. also Williams, B.P. 19096/89. The use of alternate application of pressure and the release of the same is also claimed by Linde in D.R.P. 289106/14. A series of patents by the Badische Co. follows. In B.P. 8030/14 are described special solutions of cuprous chloride which do not attack iron, containing at least 6 % of ammonia, either free or as carbonate, for use in steel

vessels under high pressure. B.P. 9271/14 deals with the employment for a similar purpose of ammoniacal cuprous solutions containing little or no halogen. Weak acids, such as acetic, may be present. According to a further patent, B.P. 20616/14, the addition of oxygen is prescribed in the use of ammoniacal cuprous solutions to prevent the separation of copper and also to effect oxidation of part of the carbon monoxide to carbon dioxide.

(3) *By Conversion into Methane.*—It is a simple matter to remove small quantities of carbon monoxide by conversion into methane; this is only useful in cases where the presence of a little methane is not detrimental. The conversion is effected by means of a nickel catalyst at a temperature of 250–300° C. (cf. p. 240).

(4) *By Calcium Carbide.*—Claim is made by Frank, in B.P. 26808/06, for the purification of hydrogen from carbon monoxide, carbon dioxide, nitrogen and hydrocarbons by passage over calcium carbide at a temperature over 300° C. (Actually a much higher temperature than 300° C. is required.) The carbide may be mixed with other substances to promote the action. A later patent, B.P. 26928/06, prescribes a preliminary purification from oxides of carbon and other impurities before this treatment.

### Purification from Carbon Dioxide

Carbon dioxide is an impurity the removal of which from hydrogen is often necessary, and a brief summary of the different methods proposed will be useful.

Small quantities of carbon dioxide may be removed by ordinary lime purifiers, *i.e.* boxes containing trays of slaked lime; if larger amounts are present, other methods are preferable, the most important being dependent on the action of water under pressure.

In B.P. 1471/73 Baggs claims the removal of carbon dioxide by washing with water or sodium carbonate solution under pressure, and Lane, in B.P. 11878/10, abstracts carbon dioxide, sulphuretted hydrogen and sulphur dioxide from hydrogen by water under a pressure of several atmospheres,

the energy of the released water being utilized. A process described by Claude, in B.P. 15053/14, depends on the use of lime-water instead of water in the pressure absorption. By adopting a counter-current system the final purification is effected by alkali and the initial treatment by water.

In the use of water under pressure, it is usually necessary to complete the action with caustic solution, preferably also under pressure. Reference has already been made to the removal of carbon dioxide by the Bedford process of scrubbing with water under pressure in connection with the B.A.M.A.G. continuous catalytic process and the Linde-Frank-Caro process for the manufacture of hydrogen.

Solution may also be effected by ammonia liquor (Claus, B.P.s 15173/88 and 50/89), or by alkali carbonate or alkaline earth carbonate solutions (Reissig and Landin, B.P. 2021/91), the carbon dioxide being subsequently expelled by heating, reduced pressure being also employed in the case of carbonate solutions, cf. pp. 264-8.

### Purification from Sulphur Compounds

Sulphuretted hydrogen may be removed to a considerable degree of completeness by treatment with bog iron ore in purifiers such as are used in ordinary gas works practice. Several patents have been brought forward with the object of effecting a more rigorous purification, *e.g.* in U.S.P. 1034646/12, Rabenalt proposes to remove sulphuretted hydrogen by passing through a solution of iodine which is continuously regenerated by means of an electric current. According to Pintsch, Strache and Hiller, in D.R.P. 286374/14, sulphuretted hydrogen is removed by passing rapidly through an ordinary oxide purifier first and then through copper sulphate solution. The residual copper sulphide is reoxidized to sulphate by heating in air of oxygen at a temperature sufficiently high to prevent separation of sulphur.

The removal of carbon disulphide and organic sulphur compounds is much more difficult than that of sulphuretted hydrogen. Carbon disulphide can be partially removed by passage through foul lime (*i.e.*  $\text{Ca}(\text{SH})_2$ ) as in ordinary gas

works practice, but the process is very unsatisfactory. In B.P. 14509/13, the Badische Co. prescribes the action of heated caustic soda solution under a pressure exceeding 5 atmospheres for the removal of sulphur compounds, including organic sulphur compounds. Thus, a temperature of 150–225° C. may be used for a 10–25 % caustic soda solution at 50 atmospheres (cf. also pp. 208, 250).

A very interesting process has been evolved by Carpenter and Evans (B.P. 29673/10; *Trans. Inst. Gas Eng.*, (1914), 183) in connection with coal gas and is in use on a very large scale by the South Metropolitan Gas Co., one installation treating 15,000,000 ft.<sup>3</sup>/diem. The carbon disulphide is converted into sulphuretted hydrogen by passing the gas over reduced nickel at a temperature of about 430° C., the sulphuretted hydrogen being subsequently absorbed in the usual way. The carbon disulphide content is reduced from, say 40 grains/100 ft.<sup>3</sup>, or 0.029 % by volume, to about 1/5 of this value. Carbon is deposited on the catalyst and is removed by the periodic passage of air about every month.

According to Guillet, in B.P. 18597/12 and "Soc. Tech. de l'Industrie du Gaz de France," (1912), 245, carbon disulphide may be removed catalytically by passing the gas, freed from sulphuretted hydrogen, at a temperature of 80–200° C. in the presence of water vapour over iron oxide which absorbs the sulphuretted hydrogen formed. If air also be added, the sulphuretted hydrogen and the carbon disulphide may be removed in a single operation; in this case the exit gases are preferably washed with alkali. In B.P. 3752/10, Bedford and Williams deal with the removal of sulphur compounds, etc., by cooling the gas to –190° C. The removal of sulphur dioxide is effected by the methods given above for carbon dioxide and will take place at the same time if both impurities are present.

### Purification from Other Impurities

The removal of arseniuretted hydrogen has been proposed by bubbling through petroleum cooled to –110° C. by Renard (*Comptes Rend.*, 136, (1903), 1317), and according to Wentzki

(*Chemische Industrie*, **29**, (1906), 405) the same object may also be achieved by the use of bleaching powder or by passing through a red-hot tube containing copper turnings.

Reference has been made already to the removal of small quantities of oxygen in connection with the manufacture of electrolytic hydrogen; when the absence of this impurity is desired, it is very readily secured by passage over heated platinized pumice or other catalyst.

### Comparison of Costs of Production and Purity Attainable by the Different Methods

The following table will serve to give some idea of the relative merits of the different processes from an economic standpoint. The costs, which are on a pre-war basis, are to be regarded as rough approximations only. Overhead charges are not included. The low prices claimed for some of the processes are to be taken with reserve, especially for those which have not been developed, *e.g.* the Bergius process. The cost of electrolytic hydrogen is conditioned by the very variable price of electric energy and also by the credit for the oxygen. Reference may be made to Table 25, giving the cost of production by various "Field Processes."

As regards purity, values have also been inserted in the table. Generally speaking, it may be stated that the electrolytic process, the Carbonium process and the Bergius process are those which alone give hydrogen of a high degree of purity. Hydrogen from the Linde-Frank-Caro process is quite free from sulphur compounds, while that made in the B.A.M.A.G. continuous catalytic process is practically equally good in this respect. In both processes, however, an appreciable amount of carbon monoxide is present, as is also the case in a greater or less degree in all the remaining processes. The nitrogen content is of special importance only in connection with aeronautics, in diminishing the lifting power of the hydrogen. All the usual impurities found in technical hydrogen have roughly the same density and, consequently, the same effect on the lifting power. The impurity of most importance is carbon monoxide, especially when the hydrogen is to be used

for the manufacture of ammonia by the Haber process and in a lesser degree when used for the hydrogenation of oils (cf. "Applications of Hydrogen," p. 214).

Taking everything into consideration, there can be little doubt that the B.A.M.A.G. continuous catalytic process is the most suitable for use in this country for such purposes as the production of synthetic ammonia, when the cost of the hydrogen is of paramount importance. On the other hand, the purity is not very high and especially for ammonia synthesis, further purification from carbon monoxide is necessary. Electrolytic hydrogen is only likely to be a serious competitor in places where cheap water power is available. For aeronautical purposes the Lane and allied processes are probably the most satisfactory, as giving a high percentage of hydrogen at a moderate cost; the elimination of nitrogen from the gas obtained from the B.A.M.A.G. process is not practicable.

TABLE 23.

COST OF PRODUCTION AND PURITY OF HYDROGEN BY DIFFERENT PROCESSES (STATIONARY PLANTS).

Process.	Cost per 1000 ft. <sup>3</sup> Shillings.	Purity (% hydrogen).	Percentage of carbon monoxide.
B.A.M.A.G. continuous catalytic process .. .. .	1·75	ca. 92 %	1·5-3·0
Griesheim-Elektron process .. .. .	2-3	97·5 %	0·2
Linde-Frank-Caro process .. .. .	3-4	97 %	2
Lane process .. .. .	3-4	98·5-99·5 %	0·25-1·5
Messerschmitt process .. .. .	2	ca. 99 %	0·25-1·5
Bergius process .. .. .	1½-2	99·95 %	0·001
Carbonium process .. .. .	4	very pure	—
Rincker and Wolter process .. .. .	2½-4	96 %	3
Oechelhauser process .. .. .	ca. 3	80 %	7
Electrolytic processes, with current at 0·25 <i>d.</i> /K.W.H., assuming no credit for oxygen .. .. .	3-4	very pure	nil

### Applications of Hydrogen

Apart from aeronautical requirements, the chief consumption of hydrogen in this country is in connection with the hydrogenation of oils and fats; the synthetic ammonia

industry also has assumed importance in Germany and is being developed in the United States.

**The Hydrogenation of Oils and Fats.**—In 1897, a description was given by Sabatier and Senderens of a general method for the hydrogenation of organic unsaturated substances (cf. resumé by Sabatier and Senderens, *Ann. de Chim. et de Phys.*, [8], **4**, (1905), 319; *ibid.*, [8], **16**, (1909), 70; also Sabatier, *Ber.*, **44**, (1911), 1984; "La Catalyse en Chimie Organique," 1913).

Speaking generally, the method consists in passing the organic substance in the state of vapour accompanied by hydrogen over gently heated, finely divided metals—nickel, cobalt, iron, platinum, palladium and copper being the most useful and their respective activities somewhat as in the order given. The activity of the catalyst depends on its temperature of reduction, *e.g.* nickel reduced at a bright-red heat is practically inactive, whereas when reduced at 250° C. it is excessively active but rather sensitive and variable. 300° C. is a generally useful reduction temperature. The catalysts are very sensitive to traces of "poisons," of which the most important are sulphur, chlorine, arsenic, antimony, and, in a lesser degree, carbon monoxide. For a discussion of the inhibitive action of carbon monoxide, see pp. 19, 241. Sabatier's work was carried out in the gaseous phase, and the avoidance of any liquid in contact with the catalyst is prescribed. As examples may be cited the reactions:

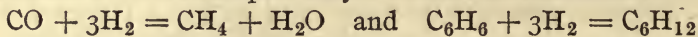

The application of the method to liquids is due to the work of Paal, Willstätter, Ipatiew, and Skita in the first instance, while the technical application is largely due to Norman (1903). The hardening of oils and fats consists in the conversion of the glycerides of the unsaturated acids into the glycerides of the corresponding saturated acids. The effect is to raise the melting point and in most cases to free from objectionable odour, taste and colour, the market value being considerably enhanced. According to Schuck (*Chem. Trade J.*, **63**, (1918), 139) deodorization without hardening may be effected by the use of hydrogen



without a catalyst. Whale oil is one of the principal oils hardened ; a certain factory in Norway is capable of hardening some 55,000 tons of whale oil per annum, using electrolytic hydrogen. Some 35,000 ft.<sup>3</sup>/hr. of hydrogen from the Linde-Frank-Caro process alone, are used for fat hardening, equivalent to about 100,000 tons of fat per annum, one ton of triolein, for example, requiring about 2700 ft.<sup>3</sup> of hydrogen. The hardened fats are extensively used as edible fats and in the manufacture of soap, candles, etc.

The catalyst usually employed is nickel, although palladium is sometimes used. According to some systems nickel from the sulphate is precipitated as carbonate in the presence of kieselguhr, the mixture filtered, the cake dried, finely powdered, calcined to convert the nickel carbonate into oxide, then reduced in hydrogen and allowed to fall without contact with air into oil with which it is intimately mixed. This mixture is added in the desired proportions to the oil to be hardened ensuring, *e.g.* 0.5-1 part of nickel to 100 parts of the oil, which is carefully dried before using. Temperatures in the neighbourhood of 150-250° C., with pressures of 5-15 atmospheres, are employed. Instead of metallic nickel the suboxide may be used. For a discussion of the constitution of nickel catalysts, see Erdmann, *J. Prakt. Chem.*, **91**, (1915), 469. After the hydrogenation the catalyst is removed by filtration and used again. The products always contain minute traces of nickel. The above remarks relating to catalyst poisons apply equally to treatment of liquids. According to Ellis (U.S.P. 1247516) the poisons present in the oil may be removed by preliminary treatment with copper hydroxide. For an account of modern developments in the manufacture of edible fats, cf. Clayton, *J. Soc. Chem. Ind.*, (1917), 1205.

**The Manufacture of Synthetic Ammonia.**—The synthetic ammonia industry in Germany has been developed from the work of Haber and collaborators and ranks as one of the finest achievements arising out of the application of physico-chemical methods to industry :

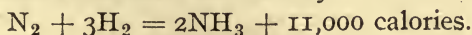

Many experimenters had previously attempted to effect the synthesis of ammonia, but without much success; an approximate calculation of the equilibrium constant

$$K = \frac{p_{\text{NH}_3}^2}{p_{\text{H}_2}^3 \times p_{\text{N}_2}}$$

by the Nernst Heat Theorem is sufficient to show that only a very small percentage of ammonia can exist at temperatures for which suitable catalysts were at that time known, *e.g.* 800° C.

$$\begin{aligned} \text{Since } c_{\text{NH}_3}^2 &= \frac{p_{\text{NH}_3}^2}{P^2} = \frac{K \cdot P^3 \cdot c_{\text{H}_2}^3 \cdot P \cdot c_{\text{N}_2}}{P^2} \\ &= K \cdot P^2 \cdot c_{\text{H}_2}^3 \cdot c_{\text{N}_2} \end{aligned}$$

where P is the total pressure, it is evident that the concentration of the ammonia is almost directly proportional to the pressure. Such considerations led Jost and, at about the same time, Haber and Le Rossignol to study the effect of high pressures, and the latter investigators worked out a series of catalysts which enabled equilibrium to be attained fairly rapidly at temperatures as low as 300° C.

The following table shows the influence of temperature on the equilibrium values:—

TABLE 24.  
EQUILIBRIA IN THE SYNTHESIS OF AMMONIA.

Temperature °C.	Percentage of ammonia at absolute pressures of—		
	1 atm.	100 atms.	200 atms.
200	15.3	80.6	85.8
300	2.18	52.1	62.8
400	0.44	25.1	36.3
500	0.129	10.4	17.6
600	0.049	4.47	8.25
700	0.0223	2.14	4.11
800	0.0117	1.15	2.24
900	0.0069	0.68	1.34
1000	0.0044	0.44	0.87

The advantage of the higher equilibrium values can be only partly turned to account by reason of the accompanying decrease of the reaction velocity. At very high temperatures, a reversal of the equilibrium sets in (cf. Maxted, *Chem. Soc. Trans.*, (1918), 168, 386; *ibid.*, (1919), 113), thus by passing a mixture of nitrogen and hydrogen through a capillary tube in which a high tension arc was burning under a pressure of 1 atmosphere, an ammonia content in the exit gases as high as 2.0 % was observed.

As in other heterogeneous gas reactions, a rise in the velocity of passage of the gases over the catalyst has the effect of lowering the percentage of ammonia, but of increasing the production; this is a matter of considerable importance as when using high pressures the available space for the catalyst is necessarily limited.

As an example of this behaviour may be cited the following results obtained at a working pressure of 114 atmospheres and with a catalyst temperature of 515° C., the catalyst employed being uranium carbide (Haber and Greenwood, *Z. Elektrochem.*, 21, (1915), 241):—

Space velocity (litres of free gas/litre catalyst space/hour) .. .. .	5800	31,650	82,600	194,000
Percentage of ammonia by volume .. .. .	7.63	6.42	4.78	4.18
Space-time-yield (kilos. ammonia/litre catalyst space/hour) .. .. .	0.318	1.46	2.84	5.83

It should be pointed out, however, that the above considerations are not the only deciding factors, as the space-velocity is limited by such considerations as regeneration of heat, ammonia absorption, etc.

Amongst the most efficient catalysts may be mentioned metallic osmium and uranium carbide, the range of useful working temperature being 500–700° C. The process was subsequently taken over and developed by the Badische Anilin und Soda Fabrik.

Since the percentage of the gases undergoing conversion

is only relatively small even at the pressures employed, e.g. 100 to 200 atmospheres, it is necessary to circulate the gases through the catalyst removing the ammonia without releasing the pressure, and passing again over the catalyst reinforced with a fresh supply of nitrogen-hydrogen mixture to replace the portion converted. The ammonia formed is removed from the system either by cooling or by absorption with water.

As regards catalysts, osmium is too expensive and too limited in amount for use on the large scale, while uranium is very sensitive to traces of oxygen or moisture (cf. Haber and Greenwood, *loc. cit.*). So far as can be gathered from the patent literature, the catalysts used in practice have a basis of pure iron with the addition of a promoter. Among such promoters may be mentioned potassium oxide, lime, magnesia, alumina, zirconia, molybdenum, vanadium and cobalt as patented by the Badische Co. Other patented catalyst groups are various alkali and alkaline earth ferrocyanides (F. Bayer & Co.); ruthenium and various ruthenates with special supports such as chromic oxide (Centralstelle für wissenschaftlich-technische Untersuchungen), and sodamide with different promoters as manganese, cobalt, cerium, etc., by De Jahn.

It is important to avoid certain catalyst poisons such as sulphur, phosphorus, arsenic, lead, tin, oil, impurities carried mechanically by the gases from steel piping, carbon monoxide, etc. Of these poisons the last mentioned is not the least troublesome. The presence of small quantities of sulphur in the iron used in making up catalysts is sufficient to inhibit or diminish the activity while it is necessary to free the hydrogen, usually prepared from water gas, from sulphur, carbon monoxide, etc. The removal of oxygen and water vapour from the gases is also desirable in most cases.

If the walls of the vessels containing the catalyst are allowed to become heated, trouble is experienced through the action of the hydrogen on the steel at the high temperatures in question, namely, 500–700° C. Under these conditions the carbon of the steel is converted into methane and the

tensile strength of the steel lowered considerably. The difficulty may be minimized by the use of special steels low in carbon and containing nickel, chromium, tungsten, etc., as hardening agents; or avoided by internal electric heating, the pressure-resisting walls being maintained cold. Other special methods of preserving the steel from attack have been proposed (cf. B.P.s 20127/10, 1490/12, 8617/12, 28200/12, 29260/12, 9661/14, and 100216/16).

It is specially important to employ efficient heat-interchangers in the case of electric heating, the problem being comparatively simple when dealing with compressed gases; similarly as regards the separation of ammonia by cooling.

In order to guard against explosions through accidental admixture of oxygen with the gases (since small quantities, *i.e.* more than 5 % (cf. p. 203) suffice to produce explosive mixtures) automatic oxygen detectors are preferably employed (cf. p. 34), while the catalyst containers may be disposed in bomb-proof chambers.

The first Badische plant was erected at Oppau in 1912 and produced some 9000 tons of ammonia per annum, a Linde-Frank-Caro plant of capacity about 70,000 ft.<sup>3</sup>/hr. being installed for providing the necessary hydrogen; subsequently, and particularly during the war, the plant has been greatly extended and at the present time the production is probably of the order of 100,000 tons of ammonia per annum. Recently another large works has been erected at Leuna, near Merseburg. There can be no doubt that this process played a large part in providing the German Army with explosives during the war.

The hydrogen, the cost of which, in the requisite high state of purity, represents a large fraction of the whole, is prepared by the B.A.M.A.G. continuous catalytic process (cf. p. 161). Except in special cases where cheap power is available, the use of electrolytic hydrogen, so eminently suitable by reason of its purity, is out of the question in view of its high cost. The national importance of the fixation of atmospheric nitrogen, involving independence of overseas supplies of Chile nitrate, is obvious, ammonia produced by

direct synthesis being specially suitable, on account of its purity, for oxidation to nitric acid. The Haber process has particular advantages for this country as the power consumption is very small compared with the requirements of other processes for nitrogen fixation, the direct arc process, the cyanamide process, etc. (cf. p. 117). During the war the importance of the Haber process was forced into general notice among the Allied Nations. In this country extensive investigations have been carried out on the synthesis of ammonia (*J. Soc. Chem. Ind.*, (1917), 1196). Similarly in the United States a technical process has been developed by the General Chemical Co. (cf. Parsons, *J. Ind. Eng. Chem.*, (1917), 829; also B.P. 120546/18).

It is unnecessary to dwell on the uses of ammonia, usually as ammonium sulphate, for fertilizing purposes. One objection to this excellent fertilizer, as compared with other sources of combined nitrogen, is its demand for sulphuric acid, which is useless except for the purpose of fixing the ammonia. In order to avoid this point, many patents have been taken out with reference to the use of gypsum, which is caused to interact with ammonium carbonate (see below), e.g. B.P. 27962/13, of the Badische Co., which relates to the troublesome operation of filtering the resulting calcium sulphate and of washing the same free from ammonium sulphate by means of immersion filters (cf. Bosch, *Z. Elektrochem.*, 24, (1918), 361). Other recent patents of the Badische Co. are interesting; they relate to the use of ammonium carbonate as a fertilizer. The use of this compound, containing 36 % combined nitrogen as compared with about 20 % in ammonium sulphate, is specially important in connection with the manufacture of hydrogen by the continuous catalytic process, which produces large quantities of carbon dioxide as a by-product. For an interesting discussion by Matignon of the validity of the Badische patents in relation to certain patents by Tellier, the Société Christiania Minekompani, etc., see "Comptes Rendus de la Séance d'Inauguration des travaux de la Société de Chimie Industrielle," p. 46; *Chem. Trade J.*, 62, (1918), 413.

**Other Applications of Hydrogen.**—In addition to the above detailed uses hydrogen has been used extensively for the autogenous fusion of metals, the flame being fed with air or oxygen; thus, the "lead burning" of the seams of chemical lead work is often conveniently carried out with the oxy-hydrogen blowpipe, similarly with the welding and cutting of iron. The use of the more conveniently generated acetylene is, however, becoming more universal and has practically displaced that of hydrogen for such purposes (cf. "Applications of Oxygen"). There are still points in favour of hydrogen when the oxygen is generated electrolytically and the hydrogen is a waste product. The oxy-hydrogen blowpipe is used for the fusion of platinum in lime crucibles, also for the working of fused silica. The application of hydrogen to the manufacture of artificial gems was initiated by Verneuil and Paquet about 1900 and later developed by Wild, Miethe and Lehmann. Thus, alumina alone gives artificial corundum, while with about  $2\frac{1}{2}$  % chromic oxide rubies are obtained, similarly sapphires and emeralds may be produced, more than 1 ton of gems per annum being thus manufactured. Synthetic rubies are valuable for small bearings.

Another application of hydrogen is in the electric lamp industry; it is extensively used in the reduction of the tungsten and in working up into drawn wire filaments, also for the filling of the bulbs before evacuation, usually in admixture with about an equal volume of nitrogen. The use of hydrogen for aeronautical purposes is dealt with in the next section.

Hydrogen at a pressure of 120 atmospheres and costing about  $\frac{1}{2}d.$  per ft.<sup>3</sup> is sold in cylinders painted red, with left-handed connections.

The estimation and testing of hydrogen are discussed at the end of Section VII.

#### REFERENCES TO SECTION VI.

- General.**—Ellis, "The Hydrogenation of Oils, Catalysers and Catalysis, and the Generation of Hydrogen." London, 1915.  
Brähler, "Chemie der Gase." Frankfurt a.M., 1911.  
Lepsius, "Sur la Fabrication et les Applications de l'Hydrogène," *Monit. Scient.*, (1912), 493.

- Sander, "Neuere Verfahren zur Wasserstoffgewinnung," *Z. angew. Chem.*, (1912), ii., 2401.
- Blum, "New Methods of Obtaining Hydrogen," *Metall. and Chem. Eng.*, (1911), 157.
- Crossley, "The Preparation and Commercial Uses of Hydrogen," *J. Soc. Chem. Ind.*, (1914), 1135.
- Linde-Frank-Caro Process.**—Linde, "Die Wasserstoffgewinnung," *Z. angew. Chem.*, (1913), iii., 814.
- Linde, "Separation of the Constituents of Mixtures of Gases by Liquefaction," *J. Soc. Chem. Ind.*, (1914), 714.
- Lane and Allied Processes.**—Barnitz, "Production of Hydrogen by the Iron Contact Method," *Chem. Trade J.*, 60, (1917), 547.
- Anon., "The Generation of Hydrogen," *The Engineer*, (1917), 546.
- Electrolytic Hydrogen.**—Engelhardt, "The Electrolysis of Water" (Richards). Easton, Pa., 1904.
- Applications.**—Frankland, "The Chemical Industry of Germany," *J. Soc. Chem. Ind.*, (1915), 309.
- Hydrogenation of Oils and Fats.**—Henderson, "Catalysis in Industrial Chemistry." London, 1919.
- Maxted, "Catalytic Hydrogenation and Reduction." London, 1918.
- Ammonia Synthesis.**—Haber and Le Rossignol, "Bestimmung des Ammoniakgleichgewichtes unter Druck," *Z. Elektrochem.*, 14, (1908), 181; "Über die technische Darstellung von Ammoniak aus den Elementen," *ib.*, 19, (1913), 53.
- Haber in collaboration with Tamaru, Ponnaz, Maschke, Oehlom and Greenwood, *Z. Elektrochem.*, 20, (1914), 597; 21, (1915), 87, 128, 191, 206, 228, 241.
- Haber, "Die Vereinigung des elementaren Stickstoffs mit Sauerstoff und mit Wasserstoff," *Z. angew. Chem.*, (1913), iii., 323.
- Bernthsen, "Synthetic Ammonia," *8th Int. Congress of App. Chem.*, N.Y., 1912.
- Lunge, "Coal Tar and Ammonia," Fifth Edition, Part III. London, 1916.
- Norton, "Utilization of Atmospheric Nitrogen," *Dept. of Commerce and Labour, U.S.A.*, Special Agents Series, No. 52.
- Partington, "The Alkali Industry." This Series. 1918.



## SECTION VII.—THE PRODUCTION OF HYDROGEN FOR MILITARY PURPOSES

**Field Processes.**—Of late years, and particularly during the war, the production of hydrogen by portable or semi-portable plants for military purposes has assumed great importance. In the early days of ballooning the only available method of preparing the hydrogen was by the action of sulphuric acid on iron or zinc which process had the great disadvantage of requiring a large weight of material, and although of comparatively little importance with the small balloons at first employed, this disadvantage has now rendered the method quite obsolete.

The first use of methods involving less weight of material was in the Russo-Japanese war in 1904. In the Soudan war of 1885 and also in the Boer war of 1898–1902 hydrogen was transported from England in cylinders. Some 50 horses were necessary for the transport of the cylinders required for a balloon of 14,000 ft.<sup>3</sup> capacity. It is interesting to note that the weight of the steel cylinders is of the order of 1 lb. per ft.<sup>3</sup> of hydrogen content. Attention was consequently paid to methods allowing of the convenient and rapid generation of the hydrogen in the field.

The progress of the large dirigible has been dependent on the advance of the chemistry of hydrogen production and has, in turn, served as a stimulus to the evolution of new processes. Since the advent of the Zeppelin in 1898, the capacity of balloons\* and the demand for hydrogen in quantity have risen steadily, so that at the present time the various types of military hydrogen plants may be classified under three headings :—

(1) Apparatus of a simple and easily portable nature,

\* British rigid dirigibles having a capacity of 2 to 3 million ft.<sup>3</sup> have been constructed ; German Zeppelins of 2 million ft.<sup>3</sup> capacity were used.

involving a small weight of material and capable of giving rapid generation in the field, the cost of production being of secondary importance in this case.

(2) Apparatus for use in permanent camps, forts, aviation depôts, etc. Here, again, speed of erection and rapid output may be of more importance than economy.

(3) Plant suitable for economical manufacture on a large scale with a view to subsequent distribution by means of cylinders.

### Portable Apparatus for Use in the Field

Progress in this direction is very intimately connected with the name of the French chemist, Jaubert. Some of the most important methods are the following :—

**Silicon and "Silicol" Processes.**—These two processes, which have been extensively adopted for military purposes by the European armies, are very similar, both depending on the action of silicon on alkalis. The former, however, uses commercially pure silicon, while ferro-silicon (rich in silicon), which has the advantages of being cheaper and more easily produced, is employed in the latter.

Owing to hydrolytic dissociation of the sodium silicate, less caustic soda is required than that corresponding to the equation :

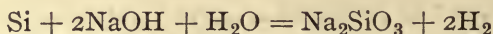

The International Chemical Co., in B.P. 14124/1900, claims the manufacture of hydrogen by treating silicides of the alkaline earths with water. A substance  $\text{Si}_2\text{H}_2$ —silico-acetylene—produced by treating calcium or strontium silicide with acids, gives hydrogen with alkalis. In B.P. 21032/09, the Consortium für Elektrochemische Industrie, G.m.b.H. describes the production of hydrogen by the action on silicon of caustic soda solution with the addition of milk of lime, less caustic soda being thus required. A later patent, B.P. 11640/11, relates to the attainment without an independent boiler, of the temperature necessary for the reaction—(1) by a preliminary reaction as, for example,

the solution of aluminium in the caustic soda, and (2) by adding the alkali to the water in the form of powdered sodium hydroxide or oxide. A further series of patents is due to Jaubert, who employs ferro-silicon instead of silicon. According to B.P. 17589/11 (cf. also F.P. 430302/10), ferro-silicon, or mangano-silicon, is treated with a concentrated solution of potassium sulphate or sodium sulphate containing alkali. The salts serve to raise the boiling point and so increase the reaction velocity. The same object is attained in F.P. 433400/10 by the use of increased pressure. In B.P. 7494/13 is prescribed the use of a layer of unsaponifiable oil facilitating the admixture of the ferro-silicon with the caustic soda solution and ensuring very rapid generation of gas; water is added to replace that lost. Baillio, in U.S.P. 1178205/16, combines the production of hydrogen with that of sodium silicate from silicon and caustic soda, the former being used in excess.

*The Schuckert Process.*—The Schuckert process depends on the use of silicon itself and has been developed mainly in Germany, as a portable field apparatus. A temperature of 80–90° C. is required for the rapid progress of the reaction and the heat of solution of the caustic soda is utilized by building the dissolver into the generator. A feed hopper is provided for the gradual introduction of the finely divided silicon, and the hydrogen passes off through a washer fed with water by a pump driven by a petrol engine. Plants of this type have been constructed with a capacity of 2000–4000 ft.<sup>3</sup>/hr.

The apparatus was first used by the Spanish in the Moroccan campaign, and was also used by the Italians in Tripoli. Stationary plants, with a capacity of 10,000 ft.<sup>3</sup>/hr., have been set up. The caustic soda solution employed is of 20–25 % concentration; each 1000 ft.<sup>3</sup> of hydrogen requires 50 lbs. of silicon, 75 lbs. of caustic soda, and about 190 gallons of water, inclusive of cooling water.

*The Silicol Process.*—This process, due to the French chemist Jaubert, has been largely used by the French military authorities. Instead of silicon, the cheaper ferro-silicon,

containing 90 % or more silicon, is employed. Using a 35-40 % caustic soda solution, the action takes place energetically at 60-80° C.; the concentrated solution has the effect of conserving the heat of reaction by minimizing vaporization of water, while the initial temperature required for the reaction is easily attained in dissolving up the caustic soda, no external heating being necessary.

Portable plants, with an hourly output of 14,000 ft.<sup>3</sup>, have been built; the usual pattern, however, has a capacity of about 2500 ft.<sup>3</sup>/hr. and is mounted on a 3-ton lorry. The general arrangement of the apparatus is almost the same as in the Schuckert plant.

Large stationary plants on these lines have been erected for the British Navy at Chatham and elsewhere during the war, by the Société Française l'Oxylithe. The plant at Chatham has a capacity of some 50,000 ft.<sup>3</sup>/hr. The caustic soda, broken into small pieces, is stirred with 1½ times to twice its weight of water in a dissolver, whereby a temperature of 60-80° C. is reached; the solution is then run into the generator. By means of a mechanically-operated distributor, the finely powdered ferro-silicon is fed into the generator which is provided with a planetary stirrer. A slow stream of paraffin or naphtha is also admitted to prevent the formation of foam which would hinder the progress of the reaction. The hydrogen is cooled and purified by passage through a scrubber fed with water and containing metal spirals, and then freed from suspended water by traversing, at high speed, a series of tubes with abrupt changes of direction. Two generators are provided, one serving as a standby.

It is obvious that the hydrogen produced in this type of stationary plant is very expensive compared with that from other processes. The very high speed of gas generation in case of necessity is, however, an important consideration for war purposes.

These two processes have some disadvantages. On account of the vigorous heat evolution a considerable amount of fairly clean water is required, while the hydrogen is liable

to contain small amounts of phosphine (according to Soyer, *Ann. Chim. Analyt.*, **23**, (1918), 221, some 0.0025 to 0.007 % by volume may be present), arsine, sulphuretted hydrogen, etc., derived from impurities in the ferro-silicon and having an injurious effect on the balloon fabrics. For data on the production of ferro-silicon, cf. Anderson, *J. Soc. Chem. Ind.*, (1917), 881.

**Hydrogenite Process.**—This process, also due to M. Jaubert (cf. *Rev. Gen. Chim.*, **13**, 341, 357), resembles the silicol process in depending on the action of alkalis on ferro-silicon, but differs in that the reaction is carried out in the absence of water and at a high temperature.

The basis of all the patents given below is the preparation of mixtures which react by auto-combustion in absence of air when the action is started by local heating, hydrogen being evolved. Similar mixtures are used for oxygen production (*q.v.*). Jaubert, in B.P. 17252/07, describes apparatus for the generation of hydrogen under pressure by the auto-combustion method. The actual generator is surrounded by and is in direct connection with the gas reservoir, the pressure being thus balanced inside and outside. The same inventor, in B.P. 153/11, deals with the production of hydrogen by the interaction of ferro-silicon, lime and caustic soda in a closed vessel, the reaction being first started by local heating. According to a later patent, B.P. 9623/11, excess ferro-silicon is mixed with an oxidizing agent and a hydrate. As examples of suitable combinations are given—(1) powdered iron 20 parts, soda-lime 10 parts, potassium perchlorate 6 parts; (2) ferro-silicon (75 % silicon) 20 parts, litharge 10 parts, soda-lime (two-thirds caustic soda) 60 parts; (3) ferro-silicon 20 parts, powdered iron 5 parts, wheaten flour 3 parts, lime 5 parts, potassium chlorate 3 parts. The reaction may also be effected by steam produced in an annular boiler round the generator. According to B.P. 5005/12, the oxidation of the ferro-silicon is effected solely by the steam generated as above, no other oxidizing agent being employed.

“Hydrogenite” consists of an intimate mixture of 25

parts of ferro-silicon (90-95 % silicon), 60 parts of caustic soda and 20 parts of soda-lime. The gray compressible powder thus obtained is pressed into blocks which are packed in air-tight cases holding from  $\frac{1}{2}$  to 1 cwt.; under these conditions the mixture is quite permanent. When required for use the lid is removed, the box placed in the generator, and the heavy lid of the latter, kept in position by its weight alone and serving as a safety valve, is put on. The mass is then ignited through a small hole in the lid by means of a match applied to a small quantity of priming powder, when the reaction propagates itself throughout the mass, without production of flame, hydrogen being produced very rapidly. The generator is surrounded by a water jacket in which steam is generated. Towards the end of the reaction this steam is admitted to the generator, serving to increase the yield and to quench the mass. The hydrogen is washed with water and dried with coke and sawdust.

Portable plants have been used by the French Army, consisting of waggons with 6 generators grouped round a central washer; the capacity is about 5000 ft.<sup>3</sup> hydrogen per hour. The method has the important advantage over other processes of requiring no water, and further, of using the same material as the important silicol process. Each 1000 ft.<sup>3</sup> of hydrogen necessitates a weight of about 190 lbs. of hydrogenite. The gas obtained is very pure.

**Hydrolith Process.**—Jaubert, in F.P. 327878/02, deals with the preparation of calcium hydride from calcium and waste hydrogen, *e.g.* from electrolytic alkali manufacture. The hydrogen, freed from water and oxygen, is passed over calcium heated to about 600° C. A later patent, B.P. 25215/07, describes an apparatus for producing hydrogen from calcium hydride, consisting of a series of generators so arranged that the moisture from one generator is removed by passing the gas through another generator filled with calcium hydride but not supplied with water. A modified process is described in D.R.P. 218257/08, by Bamberger, Böck and Wanz, who use, instead of water, substances containing combined water or carbon dioxide, *e.g.* gypsum,

sodium bicarbonate, etc., which only react when heated to a temperature above 80° C.

Hydrolith reacts with water as follows:—

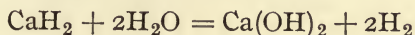

The calcium hydride is prepared by treating molten calcium with hydrogen and serves as a medium for transporting waste hydrogen to the balloons; although expensive, its use avoids the great weight of cylinders. A white crystalline powder, consisting of 90 % calcium hydride with some nitride and oxide, is obtained, and on treatment with cold water, 1000 ft.<sup>3</sup> of hydrogen are produced from the exceptionally small weight of 62 lbs. A waggon, carrying 6 generators, yields some 15,000 ft.<sup>3</sup>/hr., while plants with a capacity of 50,000 ft.<sup>3</sup>/hr. have been constructed. Such a plant with a supply of 20 tons of calcium hydride, *i.e.* capable of producing 700,000 ft.<sup>3</sup> hydrogen, was used in recent French manœuvres and behaved very well. The generators, carrying the calcium hydride on perforated plates, are supplied with water at the bottom while the hydrogen passes off at the top and is freed from water by passing through another generator containing an untreated charge which is subsequently used. A large heat evolution takes place, which at first caused inconvenience. The hydrogen leaving the generators is purified from a small quantity of ammonia before use.

**By the Action of Acids and Alkalis on Metals.**—This branch of the subject may be divided into several sections:—

(1) *Action of Sulphuric Acid on Iron or Zinc.*—In this connection there are a large number of patents, among which may be mentioned the following: Pratis and Marengo, in B.P.s 16277/96 and 15509/97, describe apparatus for the generation of hydrogen from sulphuric acid and iron (cf. also Hawkins, B.P. 25,084/97; Fielding, B.P. 17516/98, and Praceiq and Bourchaud, B.P. 6075/05).

The use of such methods for generating hydrogen is very old, and although convenient for relatively small quantities

on a large laboratory scale, for lead burning and allied purposes,\* is too expensive and involves too great weight of material for military purposes (cf. p. 234); consequently for field work these methods have been abandoned (cf. also p. 223).

A considerable amount of work was carried out by Renard (1875-1880) in the development of this process for military purposes in France. Acid of some 12 % strength was run on to iron or zinc in a leaden vessel; the hydrogen was washed with water, freed from sulphuretted hydrogen with Laming's mixture (quicklime, ferrous sulphate and sawdust) and then passed over caustic soda, the plant yielding some 1000 ft.<sup>3</sup> hydrogen per hour. Hydrogen generated from iron or zinc is liable to have a low lifting power on account of impurities and to contain sulphuretted hydrogen and, when using zinc, arsine; these impurities have an injurious action on the balloon fabrics, while the arsine is further objectionable by reason of its poisonous properties. Attempts have been made to remove arsenic from the hydrogen by passing through a heated tube containing copper turnings; by the action of potassium permanganate; cooling with liquid air, etc. (cf. p. 211). Arsenic-free acid should, of course, be used in the preparation.

(2) *Action of Caustic Soda on Aluminium.*—This method has long been known, but only recently used for military purposes. It was employed by the Russians in the Russo-Japanese war in 1904, two types of portable apparatus being employed:—(1) Two generators with a common washer mounted on two cars, the set having a capacity of 5000 ft.<sup>3</sup>/hr. (2) Two generators of light pattern carried by a pack-horse for use in mountainous country. The sheet-iron generators were filled with 30 % caustic soda solution in the lower part and a basket containing aluminium sheet clippings was lowered by means of a handle. The hydrogen was washed in a water scrubber. A very vigorous reaction takes place and an ample supply of cooling water is necessary.

\* For useful data on the preparation and compression of hydrogen on a large laboratory scale, cf. Hutton and Petavel, *loc. cit.*, p. 113.



Reference to Table 25 will show that the weight of material is still rather high although less than that required when using iron or zinc with sulphuric acid.

(3) *Action of Activated Aluminium on Water.*—Considerable attention has been paid to the activation of aluminium with mercury to ensure rapid evolution of hydrogen on treatment with water alone. A great advantage is the small weight of material requiring transport. Thus, Mauriceau-Beaupré, in F.P. 392725/08, generates hydrogen by the slow addition of water to a mixture of fine aluminium filings with 1–2% of mercuric chloride and 0.5–1% of potassium cyanide, the temperature being kept below 70° C. One gallon of water suffices for 10 lbs. of the material, which has a specific gravity of 1.4 and is permanent in absence of air and moisture. Similarly the Chemische Fabrik Griesheim-Elektron, in B.P. 3188/09, uses a mixture of finely divided aluminium with 1% mercuric oxide and 1% caustic soda. This mixture has the advantage of being less poisonous than the above. A patent by Sarason, B.P. 18772/11, prescribes the addition of a salt having an alkaline reaction, e.g. a borate, phosphate, etc., to start the action of the water on the aluminium amalgam. Uyeno (B.P. 11838/12) treats an alloy of aluminium and zinc which may also contain tin, with zinc or tin amalgam and subsequently heats to cause penetration of the mercury. The product yields hydrogen on treatment with hot water (cf. also D.R.P. 294910/16 by Elkan Erben, G.m.b.H.).

**Other Processes.**—A series of patents deals with the employment of metallic sodium, avoiding the usual violent reaction. Thus, Foersterling and Philipp, in U.S.P. 883531/08, propose to treat sodium in small pieces with a spray of water at such a rate that no solution is formed, while, according to U.S.P. 977442/10, sodium is kneaded with aluminium silicide and briquetted. The resulting product gives hydrogen on treatment with water; cf. also Philipp, U.S.P. 1041865/12. In like manner Brindley, in U.S.P. 909536/09, briquettes an intimate mixture of sodium with crude oil, kieselguhr and also aluminium or silicon, the mass being subsequently treated with water. For a proposal to use lead-magnesium

and similar alloys, cf. Ashcroft, *Trans. Faraday Soc.*, (1918), July 23. A lead-sodium alloy known as "hydrone," yielding hydrogen on treatment with water, has also been proposed. Another field method based on experiments described by Schwarz (*Ber.*, 19, (1886), 1140) has been developed by Majert and Richter, and depends on the interaction of a heated mixture of soda-lime and zinc dust :

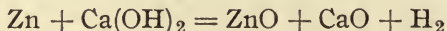

The mixture is disposed in a series of horizontal tubes mounted in a heating chamber. The use of a mixture of glycerol and caustic soda has been proposed. The process is convenient, but is rather dangerous.

### Adaptations of Stationary Types of Plant to Field Purposes

By mounting on railway trucks it has been found possible to use some of the less portable types of plant for field purposes as, *e.g.* the Rincker and Wolter process (cf. p. 192), plants with a capacity of 3500 ft.<sup>3</sup> hydrogen per hour being thus constructed. The process gives cheap hydrogen, but the lifting power is not very high on account of the nitrogen and carbon monoxide contents (see p. 193).

### Semi-Portable Plant

Certain of the processes described under (I) have been adopted for use in air stations, etc., although the expense is rather unwarrantable in such cases. Many air stations have been equipped with electrolytic plants (cf. 194). Thus an Oerlikon plant was installed at the Farnborough air station ; plants have also been put down by various European powers, while the U.S. Army had an electrolytic plant of capacity 3000 ft.<sup>3</sup>/hr.

In such cases, the stations are equipped with compression plants and with cylinders for purposes of distribution. The French Army has used very large cylinders, namely, 13 ft. long and 10½ in. internal diameter, with capacity at 130 atmospheres of about 900 ft.<sup>3</sup>. In Germany, special railway

waggons have been used, each carrying 500 cylinders, all inter-connected by soldered joints to a single discharge valve. Each waggon weighs about 30 tons and carries nearly 100,000 ft.<sup>3</sup> of hydrogen, some 8 such waggons being required for a dirigible of volume 700,000 ft.<sup>3</sup>.

### Stationary Plants

In this category may be included practically all the processes described in Section VI. The hydrogen may be distributed in cylinders as described above. Utilization of waste electrolytic hydrogen has already been mentioned; the gas may be piped directly to the aerodrome or may be distributed in cylinders. On account of the much greater economy of production possible by such methods, hydrogen can be so made for aeronautical purposes in large quantities with advantage, provided that the freight costs are not too great. The Linde-Frank-Caro has the advantage with regard to aviation, that it is adaptable to the recovery of the hydrogen in spent balloon gas, *i.e.* hydrogen which has to be discarded by reason of its diminished lifting power on account of the diffusion through the fabric of a considerable quantity of air, *e.g.* 25 %.

**General.**—There are three important considerations relating to the manufacture of hydrogen for balloons—(1) lifting power as determined by purity; (2) effect on the fabric; (3) cost.

(1) *Lifting Power of the Hydrogen.*—Since 1000 ft.<sup>3</sup> of pure hydrogen at 15° C. weigh 5·319 lbs. and 1000 ft.<sup>3</sup> of dry air at 15° C. weigh 76·49 lbs., it follows that the lifting power of pure hydrogen at 15° C.

$$\begin{aligned} &= 76\cdot49 - 5\cdot32 \text{ lbs./1000 ft.}^3 \\ &= 71\cdot17 \text{ lbs./1000 ft.}^3 \end{aligned}$$

A simple calculation will show that the presence of 1 % of air derived by diffusion through the envelope, would lower the lifting power by exactly 1 %, while the presence of the water vapour corresponding to 15° C. would have a like effect. The influence of the saturation of the air is obviously

small, saturation at 15° C., for instance, only reducing the lifting power by 0·7 %.

(2) *Effect on Fabrics.*—It has been found that sulphuretted hydrogen, arsine and phosphine have an injurious effect on the balloon fabric, probably due to oxidation of the impurities to sulphuric, arsenic and phosphoric acids respectively. Electrolytic hydrogen has an advantage from this point of view over that produced by other methods.

(3) *Costs.*—The following table shows the relative costs, as far as data are available, of various field methods for making hydrogen, together with the weights of material (water excluded) required per 1000 ft.<sup>3</sup> of hydrogen. The costs must be considered as approximations only and in any case refer to pre-war conditions.

TABLE 25.

COST OF PRODUCTION OF HYDROGEN AND WEIGHT OF MATERIALS REQUIRED BY DIFFERENT FIELD PROCESSES.

Process.	Cost per 1000 ft. <sup>3</sup>		Material required
	Shillings.		per 1000 ft. <sup>3</sup>
			Lbs.
Silicon (Schuckert) process .. ..	20		125
Silicol (Jaubert) process .. ..	20		120
Hydrogenite process .. .. .	40		190
Hydrolith process .. .. .	70		60
Iron and sulphuric acid .. ..	15-25		450-500
Zinc and sulphuric acid .. ..	40		450-500
	(with O. V. (80 %) at 25s. per ton)		
Aluminium and caustic soda .. ..	70		350
Activated aluminium and water:			
Mauricheau-Beaupré process .. ..	50		50
Griesheim-Elektron process .. ..	50		60

Before leaving the subject of balloons, it is interesting to note that proposals have been made to substitute helium for hydrogen on account of the non-inflammability of the former in conjunction with its high lifting power.

Thus, the weight of 1000 ft.<sup>3</sup> of air at 15° C. = 76·49 lbs.

    "    "    "    helium    "    = 10·56 lbs.

Consequently the lifting power of 1000 ft.<sup>3</sup> of

  helium at 15° C. .. .. . = 65·93 lbs.

or 92 % of that of hydrogen.

**Estimation and Testing of Hydrogen.**—Hydrogen is not readily estimated in gaseous mixtures by simple absorption, although, if desired, absorption can be effected by means of metallic palladium, by chlorate solutions in the presence of colloidal osmium or by other allied methods (cf. the work of Paal, Hofmann and others, p. 155).

In general, hydrogen is usually estimated by combustion with excess oxygen; this operation may be effected in various ways, *e.g.* by explosion, in a Grisometer or over palladized asbestos, or copper oxide may be used without addition of oxygen. When hydrogen and methane occur together, fractional combustion can be effected quite cleanly by attention to temperature, both with palladized asbestos and copper oxide.

Turning to the examination of commercial hydrogen, the purity can be readily determined to a first approximation by means of physical methods, *e.g.* by effusion. Impurities, such as carbon monoxide, carbon dioxide and oxygen, are easily estimated by methods described under these gases, while reference has been already made to the automatic detection of oxygen in electrolytic hydrogen, etc. Nitrogen is best determined by combustion with copper oxide and measurement of the residue. Hydrogen made by the B.A.M.A.G. continuous catalytic process contains methane which, in view of the small quantity present, is best estimated by complete combustion of a stream of the hydrogen with excess oxygen and determination of the resulting carbon dioxide, due allowance being made for any carbon monoxide present. Alternatively the estimation may be performed by explosion and subsequent measurement of the carbon dioxide formed. The Silicol process gives hydrogen containing traces of phosphine; according to Soyer (*loc. cit.*, p. 227) the products of combustion of from 2–20 litres of the hydrogen are taken up with water and phosphoric acid estimated as phosphomolybdic acid. Arsenic may be estimated by the usual method of passing the gas through a heated glass capillary and comparing the mirror with standards, or by the Gutzeit method depending on the production of a brown or yellow

stain on mercuric chloride paper. Sulphuretted hydrogen and carbon disulphide may occur in hydrogen; the former may be estimated by its action on lead acetate paper or on iodine solution, etc., while the latter may be similarly determined after its conversion into sulphuretted hydrogen by passing over platinized pumice at 300–350° C.

#### REFERENCES TO SECTION VII.

Sander, "Zur Geschichte der Wasserstoffgewinnung im Kriege," *J. Gasbeleucht.*, **58**, (1915), 637.

Anon., "Hydrogen for Balloons," *Engineering*, **99**, (1915), 415.

Boyer, "La Nouvelle Usine à l'Hydrogène de l' Arsenal de Chatham," *La Nature*, (1915), i. 144.

Fourniols, "La Fabrication de l'Hydrogène pour le Gonflement des Ballons," *Rev. Gen. des Sciences*, **26**, (1915), 339.

## SECTION VIII.—CARBON MONOXIDE

**Properties of Carbon Monoxide.**—Carbon monoxide is a colourless gas which, according to Merriman, has a definite metallic odour and taste. The chief physical properties will be found in Tables 12 and 13, pp. 53-56. The solubility in water is given by the following table :—

Temperature °C. . . . .	0	10	15	20	40
C.c. of gas, measured at N.T.P., dissolved by 1 c.c. of water under a pressure of 1 atm. exclusive of water vapour	0.035	0.028	0.025	0.023	0.018

Carbon monoxide is readily formed by the combustion of carbon in a limited supply of oxygen and by a number of chemical reactions. The most important commercial form of carbon monoxide is in admixture with nitrogen, hydrogen, etc., in producer gas, water gas and the like.

Carbon monoxide is a poisonous gas, forming a compound with the hæmoglobin of the blood (carboxyhæmoglobin), and is only very slowly replaced by the normal oxygen. A concentration of 0.4 % is rapidly fatal. Carbon monoxide burns with a characteristic blue flame to carbon dioxide. It is very stable at high temperatures, especially in the presence of a trace of moisture (Woltereck, *Comptes Rend.*, **147**, (1908), 460), but in the neighbourhood of 300° C. and in the presence of a catalyst, e.g. metallic nickel, decomposition takes place according to the following equation :—

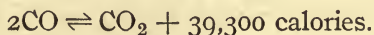

The following table gives the percentages of carbon dioxide in equilibrium with carbon monoxide and carbon at different temperatures and at atmospheric pressure. The

values above 850° C. are taken from Rhead and Wheeler (*Chem. Soc. Trans.*, (1910), 2178; (1911), 1141) and the lower values from Boudouard (*Annales de Chimie et de Phys.*, [7], 24, (1901), 5).

TABLE 26.—EQUILIBRIUM BETWEEN CARBON

Temperature °C. .. ..	450	500	600	700
Percentage CO <sub>2</sub> } B. .. by volume } R. and W.	98	95 .	77	42
$\frac{p_{CO_2}}{p_{CO}}$ .. .. .	49.0	19.0	3.35	0.724
$K = \frac{p_{CO_2}}{p^2_{CO}}$ .. .. .	2450	380	14.55	1.25

Rhead and Wheeler adopt the modified Le Chatelier formula given below as in agreement with their measurements.

$$\log_e \frac{c^2_{CO}}{c_{CO_2}} = 18.74 - \log_e P - \frac{38,055 + 2.02T - 0.0031T^2}{2T}$$

In view of the decrease in volume as decomposition proceeds, it is obvious that the effect of increased pressure will be to favour such decomposition. Experiments by Briner and Wroczynski (*Comptes Rend.*, 150, (1910), 1324) have demonstrated that at 400 atmospheres carbon monoxide is not decomposed at the ordinary temperature even in the presence of platinized asbestos; at 320–360° C. slow decomposition occurred, a diminution in volume of 10% being observed after 20 hours.

Carbon monoxide reacts with water vapour at quite low temperatures, e.g. 400° C., in the presence of a suitable catalyst, giving the so-called water gas equilibrium—

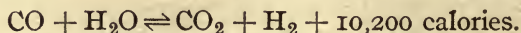

This equilibrium is dealt with elsewhere, see pp. 157 and 309. The equilibrium constant becomes unity at a temperature of about 830° C., which means that below this temperature



carbon monoxide is a more active reducing agent than hydrogen and above this temperature less so. Thus, it is found that carbon monoxide begins to reduce metallic oxides at a considerably lower temperature than does hydrogen,

MONOXIDE, CARBON DIOXIDE AND CARBON.

800	900	1000	1100	1200
7	2'22	0'59	0'15	0'06
0'0752	0'0227	0'000593	0'00150	0'0006
0'0811	0'0232	0'00597	0'001503	0'0006

cf. Fay and Seeker, *J. Amer. Chem. Soc.*, **35**, (1903), 641, and Fay, Seeker and Ferguson, *Polytechnic Engineer*, **10**, (1910), 72, who give among others the following reduction temperatures :—

	Carbon monoxide.	Hydrogen.
Cupric oxide .. .. .	75° C.	125° C.
Mercuric oxide (yellow) .. .. .	0° C.	50° C.

Silver oxide is reduced by carbon monoxide at the ordinary temperature.

On similar lines is the observation of Henry (*Phil. Trans.*, (1824), 266 ; *Phil. Mag.*, [3], **9**, (1836), 324), that when a mixture of carbon monoxide, hydrogen and oxygen is exposed to a platinum catalyst at a temperature of 150–170° C., the oxygen attaches itself mostly to the carbon monoxide ; similar results were obtained at the ordinary temperature (cf. also p. 255).

It is evident that carbon monoxide is an energetic reducing agent and many of its applications, usually as producer gas or water gas, depend on this property. It

slowly reduces silver nitrate solution, potassium permanganate solution, etc., at the ordinary temperature.

Carbon monoxide reacts readily with hydrogen in the presence of finely divided nickel (Sabatier and Senderens, *Comptes Rend.*, **134**, (1902), 514), best at a temperature of 250–300° C. according to the equation—

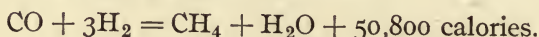

It is patent that methane production will be favoured by low temperature—consistent with sufficient reaction velocity—and high pressure. The reaction, however, goes very completely at the ordinary pressure if excess hydrogen be used at 250–300° C., and a rough calculation according to the Nernst Heat Theorem shows that starting with a mixture containing 80 % hydrogen—which with complete reaction would give, after removing water, a product containing 50 % methane and 50 % hydrogen—the equilibrium constant at 300° C. is equal to

$$\begin{aligned} & \frac{p_{\text{CH}_4} \times p_{\text{H}_2\text{O}}}{p_{\text{CO}} \times p_{\text{H}_2}^3} \\ &= \text{antilog} \left\{ \frac{50,800}{4.571 \times 573} - 3.5 \log 573 - 2.2 \right\} \\ &= 3.5 \times 10^7 \end{aligned}$$

It is evident that very little carbon monoxide can remain in equilibrium and, approximating, by taking  $p_{\text{H}_2} = p_{\text{CH}_4} = p_{\text{H}_2\text{O}} = 0.333$  atm., we have

$$\begin{aligned} p_{\text{CO}} &= \frac{0.333 \times 0.333}{3.5 \times 10^7 \times 0.333^3} \text{ atms.} \\ &= 8.6 \times 10^{-8} \text{ atms.} \\ &= 0.0000086 \% \text{ carbon monoxide.} \end{aligned}$$

At a temperature of 800° C. a similar rough calculation gives a value of 0.0035 for the equilibrium constant. (The question is, of course, complicated to some extent by the water gas reaction owing to which some of the carbon monoxide will be converted to carbon dioxide.) This corresponds to a final methane content of only about 1.7 % when starting with the above-mentioned mixture. In this connection cf. the

production of hydrogen by the decomposition of hydrocarbons, p. 189.

As an impurity of technical hydrogen carbon monoxide is important in the synthetic production of ammonia and, in a lesser degree, in the catalytic hydrogenation of oils. For the latter case cf. Maxted (*Trans. Faraday Soc.*, Dec., 1917), according to whom the presence of 0.25 % carbon monoxide in the hydrogen effects a reduction in the rate of absorption of about 30 %. The sensitivity to carbon monoxide, however, depends on the conditions of preparation of the nickel catalyst; thus, Lessing (B.P. 18998/12) introduces the nickel catalyst in the form of nickel carbonyl.

The illuminating effect of carbon monoxide as regards incandescent mantles is found by Forshaw to be 48 % greater than that of hydrogen, although the calorific value is only 18 % greater.

Carbon monoxide forms, with various metals, an interesting series of additive compounds, a description of some of which will be given later.

On cooling, carbon monoxide condenses to a colourless liquid and solidifies to a snowy solid.

The limits of inflammability of carbon monoxide in admixture with air are as follows:—

$$\left. \begin{array}{l} \text{Minimum percentage of air in carbon} \\ \text{monoxide for inflammation} \quad \dots \end{array} \right\} = 25.8$$

$$\left. \begin{array}{l} \text{Minimum percentage of carbon} \\ \text{monoxide in air for inflammation} \end{array} \right\} = 12.5$$

(Coward, see p. 40).

**Manufacture of Carbon Monoxide.**—Carbon monoxide is seldom made in a pure state on the large scale, but if required it is readily obtained by passing carbon dioxide through a bed of incandescent coke. The operation may be rendered continuous, if desired, by the addition of oxygen to the carbon dioxide (cf. Loiseau, B.P. 11590/08). Reference to p. 238 will show that a temperature of not less than 1000° C. is desirable if comparative

freedom from carbon dioxide, without subsequent purification, is necessary. With this ideal in view Benjamin (U.S.P.s 1225048/17 and 1225396/17) proposes the use of local electric heating of the carbon dioxide or coal. According to B.P. 21213/13 of the "Athion" Gesellschaft, the necessary carbon dioxide is obtained by concentration from products of combustion, using alkali carbonate lye (cf. p. 264).

Carbon monoxide is also obtained in a relatively pure state as a by-product of the Linde-Frank-Caro process, the liquid fraction usually consisting of 80-85 % carbon monoxide (cf. p. 172) the remainder being hydrogen. In most cases the carbon monoxide is burnt in a gas engine for the production of the necessary power for driving the compressors, etc., but could quite well be used for chemical purposes, *e.g.* in the Mond nickel process (cf. p. 243).

By far the most important industrial form of carbon monoxide, however, is as producer gas and water gas (cf. Section XIII.), the latter of which contains some 40% carbon monoxide. Coal gas also contains a large amount of carbon monoxide.

Carbon monoxide may be prepared in a pure state on a semi-technical scale by the action of sulphuric acid on commercial formic acid. Suitable apparatus for this purpose is described by Hutton and Petavel (*loc. cit.*, p. 113) consisting of a large glass bolthead half filled with 2 gallons of sulphuric acid of S.G. 1.73 and heated to 150-170° C. by means of a granular carbon electric resistance furnace. Ninety per cent. formic acid is run in, when carbon monoxide (of 99 % purity after washing with caustic soda solution) can be produced at a rate of about 100 ft.<sup>3</sup>/hr. and at a cost of some 50/- per 1000 ft.<sup>3</sup>. About 130 lbs. of the 90 % formic acid are required for 1000 ft.<sup>3</sup> of the gas.

### Applications of Carbon Monoxide

**General.**—It is a little difficult to draw any sharp line of distinction between the uses of carbon monoxide as such and the general applications of water gas and semi-water

gas, but among the former may be emphasized the following examples :—

**The Mond Nickel Process.**—*Metallic Carbonyls.*—Before describing in detail this interesting process, it will be well to give a brief outline of the production and characteristics of the additive compounds of carbon monoxide with metals. The first known compound, namely, nickel carbonyl, was discovered by Mond and Langer about 1889 somewhat as follows. At this time a process was in use by Mond for the production of chlorine from ammonium chloride in which nickel oxide was heated in the vapour of the ammonium chloride, giving free ammonia and nickel chloride which was subsequently reconverted into oxide and chlorine by heating in air. The nickel was used in the form of balls made up with china clay and was found to deteriorate rapidly, the effect being traced to the use of "inert" gas for the purpose of sweeping out the residual ammonia before admission of air. The "inert" gas consisted of nitrogen containing some carbon monoxide and carbon dioxide, obtained from the ammonia soda plant. In like manner, attack on the nickel valves was noticed. These observations led to the study of the action of carbon monoxide on nickel with the object of making any possible compounds. During the investigation the exit gases from the experimental tube were led to a Bunsen burner to burn up the poisonous carbon monoxide, and to the surprise of the investigators, in one experiment when the tube was cooling down, particularly when below 100° C., the flame was observed to become luminous, owing, as was subsequently shown, to the formation of nickel carbonyl.

Nickel carbonyl— $\text{Ni}(\text{CO})_4$ —is a colourless liquid of B.Pt. 43° C. and M.Pt.—25° C. The vapour is liable to explode, even at 60° C., while the liquid slowly decomposes in the air, giving a greenish deposit. On heating to about 180° C. metallic nickel is deposited in the form of a mirror. The compound is very poisonous.

The equation



indicates that the formation will take place more readily at increased pressures. According to Dewar the dissociation pressure of nickel carbonyl varies with the temperature as follows :—

Temperature.				Dissociation pressure (experimental).
100° C.	..	..	..	15 atms.
250° C	..	..	..	100 atms.

Iron likewise forms compounds under similar conditions. The compound most easily formed is the pentacarbonyl— $\text{Fe}(\text{CO})_5$ —a yellow liquid of B.Pt.  $102.8^\circ \text{C}$ . By the action of light it is converted into  $\text{Fe}_2(\text{CO})_9$ , an orange red crystalline substance which in turn, when dissolved in toluene and heated to  $95^\circ \text{C}$ . in an atmosphere of carbon dioxide, gives  $\text{Fe}(\text{CO})_4$ .

Iron carbonyl is formed in small quantities in cylinders containing compressed water gas or coal gas by the action of the carbon monoxide on the iron of the cylinders and has a deleterious action when such coal gas is used for limelight or for incandescent mantles, the iron being deposited in the form of oxide. The formation of the compound may be minimized by special treatment of the cylinders.

It was long thought that cobalt gave no parallel compound, but, in 1910, Mond, Hirtz and Cowap (*Chem. Soc. Trans.*, (1910), 798) isolated the carbonyls of cobalt, molybdenum and ruthenium. These compounds have higher dissociation pressures than the corresponding nickel and iron compounds. Thus the conditions for their formation are—

				Pressure.	Temperature.
				Atms.	$^\circ \text{C}$ .
Cobalt .. ..	..	..	..	100	200
Molybdenum ..	..	..	..	250	200
Ruthenium ..	..	..	..	450	300

Potassium with carbon monoxide at  $80-90^\circ \text{C}$ . forms a black, solid explosive compound ( $\text{KCO}$ ), which detonates at  $100^\circ \text{C}$ ., or by contact with air or water at the ordinary temperature. The formation of this compound was a source of considerable trouble in the old process of manufacturing potassium.

*The Refining of Nickel by the Mond Process.*—Following up the results of the above-mentioned investigation Mond developed the process on a technical scale. In a very comprehensive patent, B.P. 12626/90, Mond outlines a method of refining nickel based on the alternate formation and decomposition of nickel carbonyl. A number of patents follow, e.g. B.P. 8803/91 relates to the direct production of nickel alloys by passing the gas containing nickel carbonyl into a molten metal; B.P.s 23665/91 and 23665A/91 describe the arrangement of the reducer and the volatilizer with an intermediate rotatory feed valve for the ore to prevent intermixing of the gases, while B.P. 1106/98 prescribes the use of pellets as media for the continuous deposition of the nickel with appropriate plant. These patents form the basis of the process as described below. In B.P. 9300/02 Dewar deals with the action of increased pressure in the operation of the process, but this modification does not appear to have come into use in actual working; the enhanced formation of the carbonyl would doubtless be largely offset by the increased cost and difficulty of conducting operations under high pressure.

An experimental large-scale plant was erected at Smethwick in 1892 and after the success of the process had been demonstrated, a large works was put up at Clydach, the present output of which amounts to some 3000 tons of nickel, of 99.9 % purity, per annum. Details of the present plant are not available, but presumably it is similar to the Smethwick plant, of which a description is given by Mond in *Revue Gen. de Chim. pure et app.*, 2, (1900), 121. The scheme of the operations is as follows. Nickel ores containing nickel, cobalt, copper and iron as pyrrhotite (magnetic pyrites), kupfernickel, chalcopyrite, etc., are suitable. That usually adopted is pyrrhotite mixed with copper pyrites and is essentially iron sulphide containing some 3 % nickel and about the same quantity of copper; the principal deposits are in Sudbury. The bessemerized matte, containing some 80 % Ni + Cu, is roasted to convert it into oxide when it contains about Ni 35 %, Cu 42 %, Fe 5 %. It is next crushed

and screened through a 60-mesh sieve and then enriched in nickel by leaching with dilute sulphuric acid which dissolves out part of the copper, the ore having a final composition of about Ni 51 %, Cu 21 %, Fe 3 %. After drying, the ore passes to the "reducing" and "volatilizing" towers, which are superimposed, the latter being on top. By means of annular flues heated by producer gas, the "reducer," which is some 25 ft. high, is maintained at a temperature not exceeding 300° C. The "reducer" and also the "volatilizer" are provided with shelves and mechanically-operated rabblers revolving round a central vertical shaft, as in a Herreshoff sulphur burner, the ore being fed in at the top, passing from centre to periphery and vice versa; the reducer has about 14 shelves.

The nickel and copper oxides are thus reduced by a stream of water gas passing upwards as the ore descends the tower, the reduced product is cooled to about 50° C. on the lower 5 shelves, this section of the tower being water-jacketed. From the bottom of the "reducer" the reduced ore is passed out through a rotating valve and is lifted by means of an airtight conveyor to the top of the "volatilizer." This tower, which is about 15 ft. in height, is maintained at about 50-100° C. Here the reduced ore passes down in counter-current to a stream of 80 % carbon monoxide which effects the formation of nickel carbonyl, the carbon monoxide effluent having a carbonyl content of about 2 %. The ore, on the other hand, passes out through a rotating valve, which prevents the intermixing of the two types of gas, and back to the reducer.

This cyclic treatment is necessary, as the nickel after a time loses its power of yielding carbonyl and requires reactivation by further heating to 300° C. in the reducing gases.

The gases leaving the volatilizer pass through a dust filter and enter the decomposer, which consists of a tower some 10 ft. high filled with nodules of nickel previously formed, and heated to 180° C. Entering at the top, the gases pass down through a central pipe reaching to the bottom and perforated along its length, the nickel carbonyl suffering



decomposition among the pellets of nickel which gradually increase in size; the pellets pass out at the bottom of the tower through a rotating valve and are automatically screened, the smaller ones being returned to the top of the tower by an elevator while the larger pass out through a valved opening. In consequence of the constant friction, the nodules, as put on the market, have the appearance of burnished bicycle balls of about  $\frac{1}{2}$  in. diameter. This system of operating the decomposer avoids any trouble in the otherwise intermittent removal of the deposited nickel. The disengaged carbon monoxide returns to the volatilizer. To prevent blocking by deposition of nickel carbonyl within the central pipe, the latter is water-jacketed. We have here a very ingenious series of cyclic operations represented graphically in Fig. 22.

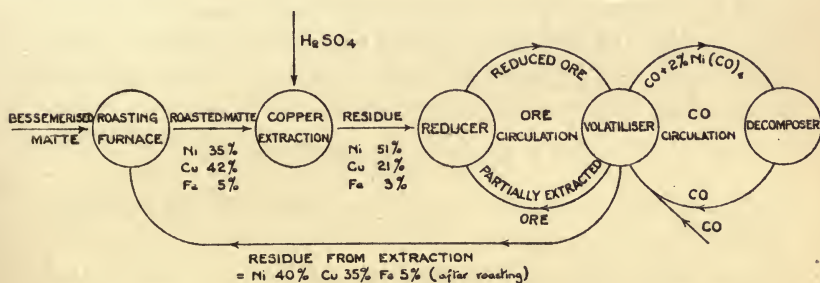

FIG. 22.—Mond Nickel Process.

It is important that the temperature of the reducer should not exceed  $300^{\circ}$  C., especially if much iron be present, as the reduction of the iron oxide would give rise to iron pentacarbonyl with consequent contamination of the metallic nickel. Further, an increase of temperature impairs the activity of the reduced nickel as regards carbonyl formation. Reduction is carried out by water gas containing about 60 % hydrogen, from anthracite generators; under the above conditions the reduction is mostly affected by the hydrogen, of which the issuing gas contains only about 5-10 %. Part of this gas, after passing first through a cooler and then through a retort filled with incandescent

wood charcoal and now containing some 80 % carbon monoxide, is used to make up the losses from the volatilizer-decomposer cycle. The ore is circulated through the volatilizer until about 60 % of the nickel is removed (residue equals about two-thirds of the original matte), this conversion occupying from 8 to 15 days, and is then of similar composition to the original matte. It is returned to the roasting furnace, leached and put into commission again. Some care is required as regards the temperature of the decomposer. If less than 180° C. the nickel is not deposited, and if above 180–200° C. catalytic dissociation of the carbon monoxide to carbon dioxide and carbon is induced.

As stated above, the purity of the nickel is extremely high, the carbon content, which is often of importance, being less than 0.1 %.

#### **The Production of Formates, Oxalates and Acetates.**

—The action of carbon monoxide on heated caustic soda was discovered by Berthelot in 1856, who showed the action to proceed according to the equation—

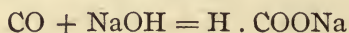

and observed that the absorption proceeded more rapidly in the presence of water.

A more complete investigation of the reaction from a technical standpoint was undertaken by Weber ("Über die Einwirkung von Kohlenoxyd auf Natronlauge," *Karlsruhe Dissertation*, 1908). Working with increased pressure and at temperatures up to 180° C., Weber arrived at the following conclusions: (1) that the reaction is of the first order; (2) that a solution containing 10 % NaOH gives the highest reaction velocity at high temperatures; (3) that the reaction occurs between the dissolved carbon monoxide and the caustic soda, not between gaseous carbon monoxide and water vapour; and (4) that for constant temperature and speed of stirring the rate of absorption is proportional to the concentration of carbon monoxide.

The experiments were continued by Fonda ("Über die Einwirkung von Kohlenoxyd auf Laugen," *Karlsruhe*

*Dissertation*, 1910) and are summarized by Haber in his Hurter memorial lecture at Liverpool (*J. Soc. Chem. Ind.*, (1914), 51). At a comparatively low temperature, stirring had little influence, the liquid being easily kept saturated with gas, but when a temperature of 160–170° C. was reached, the stirring could not be made so fast that an increase in the speed did not cause an increased rate of reaction. Above 100° C., 10 % NaOH gave the best results, *e.g.* at 160° C. the reaction velocity was more than 15 times as great with 10 % as with 43 % solution. It was thought possible that the superiority of the 10 % solution might be explained by a connection with the surface tension, but this hypothesis was not confirmed by measurements of the latter at the high temperatures in question.

Experiments by Bredig and Carter at temperatures of 50–80° C. and pressures up to 40 atms., using different bases, *e.g.* the alkalis, baryta, tetramethylammonium hydroxide, piperidene, etc., showed that the reaction velocity was constant for different bases given equal hydroxydion concentration.

There are many patents relating to this subject, among which the following may be mentioned: B.P. 17066/95, by Goldschmidt, relates to the production of formate by passing carbon monoxide over caustic soda, or preferably soda-lime, at a temperature of about 230° C., the operation being facilitated by being carried out under pressure. According to Koeppe & Co. (B.P. 7875/04) a 35 % solution of caustic soda is run on to a mass of coke at a temperature of 220° C. in a closed vessel; carbon monoxide is passed through the liquid for three-quarters of an hour. In B.P. 772/06, the Elektrochemische Werke, Bitterfeld, prescribe the treatment of caustic alkali in large pieces with carbon monoxide at 100–120° C. under pressure, while Nitridfabrik, G.m.b.H. (B.P. 9008/06) deals with the use of caustic soda with the addition of 0.12 % to 0.15 % water, such addition of water being claimed to produce improved absorption. In B.P. 13953/07 the United Alkali Co. and others claim an accelerated and more complete absorption when using solid caustic soda, by

the addition of titanium compounds, *e.g.* a mixture of caustic soda with about 11 % titanitic acid is used at a temperature of about 150° C. After evacuation, carbon monoxide is admitted with stirring, the pressure being kept low. Ellis and McElroy (U.S.P. 875055/07) prescribe the treatment of basic mineral substances, *e.g.* calcium carbonate, suspended in water, with carbon monoxide or producer gas at high temperature and pressure. Dubox, Luttinger and Denis (F.P. 421227/09) advocate the use of ammonia or organic bases in presence of pumice impregnated with one of a number of metallic catalysts at a temperature of 90–165° C. and at atmospheric pressure. On somewhat similar lines is U.S.P. 1212359/17, by Katz and Ovitz, according to whom a stream of carbon monoxide and ammonia ascending a tower, meets a descending stream of finely divided caustic alkali solution, the temperature being 150–200° C. and the pressure 10–20 atms.

The synthetic production of formates is carried out on a considerable scale, the usual source of carbon monoxide being air producer gas.

In the manufacture of formates, especially when carried out under increased pressure, the action of caustic soda liquor on steel at high temperatures is of importance from a safety standpoint. Hydrogen is absorbed by the steel, the mechanical properties of which are impaired. Cf. Andrew, *Trans. Faraday Soc.*, **9**, (1914), 317; Mercia, *Metall. and Chem. Eng.*, **16**, (1917), 496, 503; Stromeyer, *Chem. Trade J.*, **61**, (1917), 533; Worsley, *Ibid.*, **62**, (1918), 65.

*Production of Oxalates.*—On gentle heating, sodium formate is easily converted into oxalate with liberation of hydrogen and the following patents relate to such conversion.

Goldschmidt (B.P. 26172/97) heats sodium formate mixed with about 125 % of anhydrous sodium carbonate to 400–410° C., the sodium carbonate securing a good yield of oxalate and being subsequently removed. Similarly, Koeppe & Co., in B.P. 9327/03, heat sodium formate with *e.g.* 1 % of caustic soda which facilitates the decomposition. At 260° C. the molten mixture evolves hydrogen and the reaction is complete at 360° C. The use of reduced pressure

is prescribed in B.P. 19943/07 by the Elektrochemische Werke, Bitterfeld, the conversion taking place at a lower temperature, preferably about 280° C.

Other patents have as their primary object the production of mixtures of nitrogen and hydrogen through the intermediary of formates, *e.g.* B.P. 30073/13 and U.S.P. 1098139/14 (cf. p. 205), while B.P. 1759/12 relates to the removal of the last traces of carbon monoxide from hydrogen (cf. p. 208).

Acetates may be produced in a similar manner to formates by the treatment of sodium methoxide with carbon monoxide at a temperature of 180° C.

**The Production of Gases Rich in Methane.**—Carbon monoxide reacts readily with hydrogen to form methane in the presence of a suitable catalyst, as stated on p. 240. The method has been used on the large scale for the production from water gas of a gas of high calorific power with some illuminating properties.

A description is given by Erdmann (*J. Gasbeleucht.*, **54**, (1911), 737) of an experimental plant installed in England by the Cedford Gas Producing Co. (cf. B.P.s 17017/09 and 22219/09). In order to obtain a gas of suitable composition (as the action is unsatisfactory in the presence of excess carbon monoxide), the water gas was given a preliminary treatment in a Linde-Frank-Caro plant (cf. p. 172), the valves being so regulated as to give a gaseous fraction containing about 17 % carbon monoxide, *e.g.* in one test the average percentage composition of the gas was—

Hydrogen	..	..	..	..	80.9
Carbon monoxide	..	..	..	..	16.3
Nitrogen	..	..	..	..	2.8
					—————
					100.0

Part of the liquid (carbon monoxide) fraction was used for the driving of the compressors. This preliminary treatment had the advantage of giving a gas completely free from sulphur compounds which exert a poisonous effect

on the nickel catalyst. The above gas mixture was passed through three vertical quartz tubes of  $4\frac{3}{4}$  in. internal diameter and about 5 ft. long containing pumice impregnated with about 200 grams of nickel per tube. The tubes were electrically heated to 280–300° C., the gas being also preheated; after working for a little time the operation was self-supporting. Leaving through a condenser the gases had the following percentage composition:—

Hydrogen	..	..	..	..	62
Methane	..	..	..	..	31
Nitrogen	..	..	..	..	6
Carbon monoxide, carbon dioxide, etc.	..	..	..	..	Traces.

and possessed a calorific value of 263 C.H.U./ft.<sup>3</sup>, (474 B.T.U.) as against the initial value of 159 C.H.U./ft.<sup>3</sup> (286 B.T.U.) for the original water gas.

About 450 ft.<sup>3</sup>/hr. of the 16 % carbon monoxide gas was passed through the catalytic chambers, which had a volume of about 1.8 ft.<sup>3</sup>, corresponding to a "space velocity" of 250 ft.<sup>3</sup>/ft.<sup>3</sup> catalyst space/hour, referred to the 16 % carbon monoxide gas, or of 128 referred to the final gas. The cost of conversion of the water gas into the final product is given as 1.76d./1000 ft.<sup>3</sup> of the latter; this figure would appear to be low and in any case does not include any overhead charges.

**The Manufacture of Phosgene.**—Carbonyl chloride, or phosgene, is an industrial gas which may be conveniently described at this point on account of its manufacture from carbon monoxide. By passing a mixture of carbon monoxide and chlorine over platinum sponge at 400° C., combination takes place yielding phosgene, according to the following reversible reaction:—

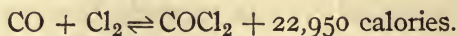

The equilibrium is given below for a pressure of one atmosphere, the values being calculated according to the

Nernst Heat Theorem (cf. Horak, *Dissertation*, Berlin, 1909).

TABLE 27.  
PHOSGENE EQUILIBRIUM.

Temperature °C.	% COCl <sub>2</sub>	% CO	% Cl <sub>2</sub>
300	92.5	3.75	3.75
400	66.9	16.5	16.5
500	29.0	35.5	35.5

It is evident that a low temperature is favourable to the production of the carbonyl chloride and that increase of pressure would also favour the reaction. The reaction takes place in the presence of animal charcoal as catalyst, either in the dark or, better, in sunlight. Thus, according to a small-scale experiment of Paterno, 70 c.c. of animal charcoal effect the formation of about 1 kilo. carbonyl chloride in 24 hours, corresponding to a "space-time-yield" of about 0.6 kilos./litre catalyst/hour. On the large scale, with coarse granulated charcoal in the dark, a considerably lower space-time-yield is to be expected. Cooling is necessary on account of the heat evolution.

Phosgene has also been manufactured by heating together electrically a mixture of quicklime, calcium chloride and ground coke—

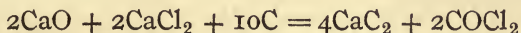

Calcium carbide is formed while phosgene distils over and may be at once converted into carbon tetrachloride by passing through a heated catalyst, *e.g.* coke, bone black, pumice, etc., carbon dioxide being formed at the same time with evolution of heat. (Cf. U.S.P. 808100/05 by Machalske.)

*Properties and Uses of Phosgene.*—Phosgene is a colourless gas liquefying at 8.2° C. It has a characteristic, unpleasant and pungent odour. The liquid has a specific gravity of 1.432 at 0° C. The substance is decomposed slowly by cold, rapidly by hot water. It is fairly reactive and is used on

a considerable scale for the preparation of di- and tri-phenylmethane dyestuffs, etc. It combines with ammonia to form urea and ammonium chloride. Phosgene is sold in the liquid state in cylinders.

With reference to its use as a poison gas, see p. 292. It is much more insidious in its physiological action than chlorine, being less irritant while its effects are only evident after a considerable number of hours and are then very severe.

**Other Applications of Carbon Monoxide.**—The use of carbon monoxide has been proposed for the reduction of organic compounds; cf. B.P. 6409/15 of the Badische Co., according to whom nitro compounds as *e.g.* nitrobenzene, are vaporized and passed with a carbon monoxide-steam mixture over a copper catalyst on pumice at a comparatively low temperature; the carbon monoxide is converted wholly or partially into carbon dioxide.

**Estimation of Carbon Monoxide.**—Carbon monoxide may be detected by its blackening action on paper moistened with palladious chloride solution, or by examination of the blood of animals, *e.g.* mice, after air containing carbon monoxide has been breathed by them. Carboxyhæmoglobin has a definite absorption spectrum and the test is sensitive to about 0.01 %. When present in sufficient quantity carbon monoxide may be estimated fairly satisfactorily by absorption in cuprous chloride solution after preliminary removal of the oxygen. The useful lower limit of the method is about 0.25 % of carbon monoxide.

By passing the dry gas over iodine pentoxide heated to about 160° C., any carbon monoxide is quantitatively oxidized to carbon dioxide according to the equation—

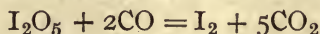

(cf. Levy, *J. Soc. Chem. Ind.*, (1911), 1437; Graham, *Ibid.*, (1919), 10 T.) By means of this reaction, concentrations of from 0.003 to 0.0003 % may be estimated in air by collecting the iodine formed. In the presence of hydrogen, in which gas the necessity of estimating small quantities of carbon monoxide often arises, the results are complicated by a small



portion of the hydrogen undergoing oxidation ; it is consequently necessary to remove the iodine first by cooling and then by bubbling through mercury which effectively removes iodine vapour, and to estimate not the iodine but the carbon dioxide formed, by suitable means. Methane is not attacked by the iodine pentoxide, but any unsaturated hydrocarbons present must be removed, best by the action of concentrated sulphuric acid at a temperature of about 165° C. (Weiskopf, *J. Soc. Chem. Ind.*, (1909), 1170). The method is accurate, without any special precautions, to about 0.01 %, provided that effective means be adopted for the accurate estimation of the carbon dioxide.

A similar preferential oxidation of the carbon monoxide may be effected by the action of chlorate solutions activated with colloidal osmium, by precipitated mercuric chromate (Hofmann, *Ber.*, 49, (1916), 1650, 1663) ; by activated copper oxide moistened with alkali, or by activated copper moistened with alkali in the presence of oxygen (Hofmann, *Ibid.*, 51, (1918), 1334) ; also by the action of precipitated mercuric oxide (Moser and Schmid, *J. Soc. Chem. Ind.*, (1914), 442). An automatic carbon monoxide recorder, designed for estimation of this gas in hydrogen, has been described by Rideal and Taylor (*Analyst*, March 1919). It depends on the catalytic fractional combustion of the carbon monoxide and subsequent estimation of the carbon dioxide by a conductivity method.

## SECTION IX.—CARBON DIOXIDE

**Occurrence.**—Carbon dioxide occurs in large quantities in a pure state, issuing from fissures in the earth, usually in the neighbourhood of volcanoes; in caverns, especially in limestone districts, and also with water in mineral springs, e.g. the mineral springs of the Volcanic Eifel and other springs in Germany and France, the Saratoga springs in New York, etc. In addition, carbon dioxide is present in small quantities in the air (cf. p. 59).

**Properties of Carbon Dioxide.**—Carbon dioxide (carbonic anhydride, carbonic acid gas) is a colourless gas with a slight acid odour and taste. It is characterized by being easily liquefiable on simple application of pressure at the ordinary temperature, and by its relatively high solubility in water.

The following table gives the relation between temperature, pressure and solubility :—

Temperature °C... ..	0	5	10	15	20	30	40	50	60
C.c. gas at N.T.P. dissolved by 1 c.c. of water under a pressure of 1 atm. exclusive of water vapour (Bohr and Bock, <i>Annalen</i> , 44, (1891), 318) ..	1·713	1·424	1·194	1·019	0·878	0·665	0·530	0·436	0·359

At increased pressures the solubility does not follow Henry's Law closely, being, according to Wróblewski (*Comptes Rend.*, 94, (1882), 1355), as follows :—

Pressure in atms. (ab- solute) .. ..	1	5	10	15	20	25	30
Solubility in c.c. per c.c. water at 12·4°C.	1·086	5·15	9·65	13·63	17·11	20·31	23·25

The specific heat shows a much larger temperature coefficient than that of most other gases being given by the following expression (Holborn and Henning, *Annalen*, [4], **18**, (1905), 7139; **23**, (1907), 809)—

$$C_p = 0.2010 + 0.0000742t - 0.000000018t^2$$

over the range 0–1400° C. where  $C_p$  = mean specific heat, and  $t$  = °C., while according to Crofts (*Chem. Soc. Trans.*, (1915), 290)—

$$C_v = 0.1500 + 0.000052t$$

where  $C_v$  is the mean specific heat between  $t$  and 15.5° C.

Carbon dioxide passes through indiarubber with greater rapidity than do most other gases (cf. p. 10).

An aqueous solution of carbon dioxide is slightly acid to litmus; the acid  $H_2CO_3$  is, however, almost entirely undissociated. Crystalline hydrates are formed at low temperatures.

On heating to very high temperatures carbon dioxide undergoes dissociation into carbon monoxide and oxygen, as is seen from the following table (\*Nernst and v. Wartenberg, *Z. physik. Chem.*, **56**, (1906), 548; †Bjerrum, *Z. physik. Chem.*, **79**, (1912), 537):—

TABLE 28.  
DISSOCIATION OF CARBON DIOXIDE.

Temperature °C. ..	*1027	*1127	*1205	†2367	†2606	†2627	†2672	†2843
Percentage of carbon dioxide which has undergone dissociation .. .. .	0.00414	0.01–0.02	0.029–0.035	21.0	51.7	49.2	64.7	76.1

These values are determined experimentally for a pressure of 1 atmosphere.

At reduced pressures the dissociation is more pronounced.

By the action of the silent discharge, or ultra-violet light, dissociation into carbon monoxide and oxygen takes place. For a discussion of the equilibrium between carbon dioxide, carbon monoxide and carbon—

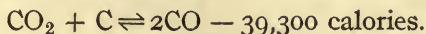

cf. pp. 238 and 303.

The conversion of carbon dioxide into carbon monoxide by the water gas reaction has also been dealt with elsewhere. Carbon dioxide is converted into methane by passage over reduced nickel at  $350^{\circ}\text{C}$ . in like manner to carbon monoxide (Sabatier and Senderens, *Comptes Rend.*, **134**, (1902), 514, 689).

Carbon dioxide is decomposed by heated magnesium with separation of carbon. It is a non-supporter of combustion and on this account is employed as a fire extinguisher. Although its poisonous action is slight, it produces suffocation by lowering the concentration of oxygen. Exhaled air contains some 4.4 % of carbon dioxide, about 2 lbs. being expired daily by an average adult. Carbon dioxide is an important factor in the rusting of iron when oxygen and water are also present. At high temperatures carbon dioxide is an energetic oxidizing agent, thus metals such as iron are attacked rapidly by the gas at a red heat.

It has been observed by Fischer (*J. Soc. Chem. Ind.*, (1915), 726) that carbon dioxide in the gaseous state behaves as a fertilizer in promoting plant growth.

*Liquid Carbon Dioxide.*—Liquid carbon dioxide is a colourless, very mobile liquid, having the following vapour pressures at the temperatures specified :—

Temperature $^{\circ}\text{C}$ .—														
Solid.														
—78.2 —70 —60 —50 —40 —30 —20 —10 0 10 20 30 40														
Vapour pressure in atms.														
(absolute)—														
										35.4	46.0	58.8	73.8	91.0*
										34.3	44.2	56.3	70.7	—†
1.00	1.88	3.92	6.73	9.88	14.21	19.52	25.83	†						

\* Regnault, 1862.

† Amagat, 1892.

‡ Zeleny and Smith, 1906.

The density of the liquid at  $15^{\circ}\text{C}$ . is 0.814 (Amagat). Liquid carbon dioxide is only slightly soluble in water, but is readily miscible with alcohol, ether, etc.

For further information as to properties, see Tables 12 and 13, also pp. 42-45.

*Solid Carbon Dioxide.*—Carbon dioxide readily assumes the solid state (about one-third of the whole) on simple release

of the liquid to atmospheric pressure. Solid carbon dioxide is a white, crystalline, snow-like substance, which can be handled with impunity in spite of its low temperature (about  $-78^{\circ}$  C.) if not pressed too much. On account of its high latent heat of vaporization, it may be kept for a considerable period without special thermal insulation. Its vapour pressure is equal to 1 atm. at  $-78.2$  (Zeleny and Smith, *Physik. Zeit.*, 7, (1906), 670). On reducing the pressure to 2.5 mm. the temperature falls to  $-130^{\circ}$  C. Mixed with ether or chloroform, an excellent refrigerating medium is obtained by means of which temperatures as low as  $-85^{\circ}$  C., or even lower if the pressure be reduced, may be obtained. Its use also forms a convenient method of maintaining moderately low temperature baths in the laboratory, e.g.  $-20$  to  $-50^{\circ}$  C. Thus, an alcohol bath may be readily maintained at a constant temperature in the region indicated by successive additions of small quantities of solid carbon dioxide.

#### MANUFACTURE OF CARBON DIOXIDE

**General.**—It is not difficult to produce carbon dioxide in a practically pure state technically, but, as in the case of sulphur dioxide, it is usually more economical either to effect a concentration of the gas from mixtures containing it, or to use it in the dilute condition.

Consequently, it will be convenient to deal separately with processes producing pure and dilute gases respectively.

#### Generation of Pure Carbon Dioxide

(1) **Utilization of Natural Sources.**—Carbon dioxide is obtained commercially from the Saratoga springs in New York, also from springs in South Germany and France. In some cases the gas is under considerable pressure as it issues from the ground, e.g. 15 atms.; the carbon dioxide is usually accompanied by a little sulphuretted hydrogen.

The procedure is very simple, consisting merely in separating the gas from the accompanying water, washing with water to which permanganate may be added in order to

remove sulphuretted hydrogen, etc., drying with calcium chloride, and finally liquefying by compression. If accompanied by nitrogen or air, concentration may be effected by absorption by water under pressure, with subsequent disengagement on release of the pressure, the water being circulated for further absorption (cf. also the general discussion of methods of concentration, p. 263).

Carbon dioxide may also be extracted from natural waters containing the gas in solution by combined evacuation and steam heating. Although the gas may be obtained in this way at low cost, the cost of transport makes other methods of production more economical for places at a distance from the springs.

### (2) By the Thermal Decomposition of Carbonates.

—Carbonates, such as calcium carbonate, are fairly easily decomposed on moderate heating. Thus, the dissociation pressure of calcium carbonate varies with the temperature as shown by the following table (Johnson, J., *Amer. Chem. Soc.*, **32**, (1910), 938) taken from a smoothed curve :—

Temperature °C...	..	..	600	650	700	750	800	850
$p_{\text{CO}_2}$ (mm. mercury)	..	..	2	8	25	67	170	380

It will be evident that a comparatively high temperature, say about 800° C., is necessary for the rapid expulsion of the carbon dioxide unless means are provided for maintaining a low carbon dioxide pressure. This is most readily effected by a current of steam, as *e.g.* in the process of Grouven (D.R.P. 26248/83), according to which limestone is heated to moderate redness in the upper portion of vertical retorts of about 10 in. diameter, in a current of steam admitted at the lower ends of the retorts. The steam is subsequently removed by condensation. On similar lines are the patents of Thom and Pryor (B.P.s 20102/08 and 24332/08). Superheated steam is employed, arrangements being provided for recuperation of heat; precautions are taken against ingress of air. Instead of limestone may be used dolomite or magnesite, which have the advantage of suffering decomposition at considerably lower temperatures. It has been proposed by Westman (B.P. 10705/00) to effect

the decomposition of limestone by circulating a mixture of steam and carbon dioxide through a heater and then through a shaft containing the limestone, cooling by injection of water, returning to the pump and so forth.

(3) **By the Action of Acids on Carbonates.**—Carbon dioxide is still prepared by the action of dilute hydrochloric or sulphuric acid on carbonates, such as limestone (whiting), marble, magnesite, etc., *e.g.* for such purposes as the manufacture of artificial mineral waters. Magnesite is often employed in Germany, the resulting solution being worked up for magnesium sulphate. A generator for the production of carbon dioxide in this way consists of a lead-lined cast-iron or copper vessel fitted with stirring gear, acid supply tank, safety valve, etc. Sulphuric acid is usually employed in preference to hydrochloric, as not giving rise to volatile impurities, but has the disadvantage of yielding an insoluble sludge with calcium carbonate. In both cases it is important that the acid should be free from arsenic. Marble often contains organic matter. Sodium bicarbonate is sometimes employed, giving a very pure but very expensive gas. Lead is always liable to be present and the use of such generators has been largely superseded by the cheap and pure liquid carbon dioxide. If desired the apparatus may be adapted to produce the carbon dioxide under the pressure required for the saturation of the mineral waters, by the employment of an acid reservoir the top of which is connected to the gas exit of the generator. The gas leaving the generator is freed from acid spray by scrubbing with water, which may be distributed on lumps of marble or limestone. Organic compounds and sulphuretted hydrogen may be removed by washing with permanganate solution, while complete elimination of acid spray is sometimes ensured by washing with sodium bicarbonate solution. When the gas is being generated with sulphuric acid, permanganate may be added directly to the generator.

In order to avoid the use of sulphuric acid, proposals have been made by Mackey and Carrol (B.P. 109511/16) to treat

calcium carbonate with a solution of nitre cake (the  $\text{NaHSO}_4$  and  $\text{Na}_2\text{SO}_4$  mixture resulting as a waste product in the manufacture of nitric acid from Chile saltpetre), use being made of the mixture of calcium and sodium sulphates produced, for glass manufacture, etc.

A cyclic process has been proposed by Howard (D.R.P. 132623/00) in the production of bisulphite by the action of sulphur dioxide (burner gases) on sodium sulphite solution, half of the resulting bisulphite solution to be used to generate carbon dioxide by interaction with hot sodium carbonate solution—

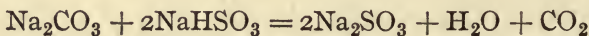

The sodium sulphite solution is re-treated with sulphur dioxide, half of it being returned to the cycle while the remainder is marketed; the carbon dioxide is cooled and washed with sodium carbonate solution.

According to Behrens (D.R.P. 305417/17) neutral or basic carbonates are decomposed by heating with water under pressure to  $150^\circ\text{C}$ . or over.

**(4) Production of Carbon Dioxide as a By-product in Fermentation Processes.**—Carbon dioxide is produced in enormous quantities by alcoholic fermentation in the manufacture of beer, etc. According to Goosmann, 1 lb. of carbon dioxide results from each 5–6 gallons of wort. As a rule, the gas is allowed to escape, but in some cases is collected. If the gas be drawn from the vats without access of air the treatment is simple and direct compression may be performed. If, on the other hand, the carbon dioxide is obtained only in the dilute state, concentration must be effected before liquefaction by one or other of the methods described below. The carbon dioxide obtained in this way has an odour of fusel oil, which is not detrimental if the gas is to be used for beer raising; if for other purposes purification by permanganate solution, sulphuric acid, etc., is necessary.

**(5) Other Methods for the Production of Carbon Dioxide.**—Among other methods of producing pure carbon



dioxide may be mentioned that due to Wallace and Ball (B.P. 24652/94—cf. also Lane and Pullman, D.R.P. 77150/93). In this cyclic process, air is passed first through a retort containing coke whereby carbon monoxide is generated, and then through a second retort charged with copper oxide. Carbon dioxide is thus formed and reaching again the coke retort, each volume produces two volumes of carbon monoxide, which in turn give two volumes of carbon dioxide—

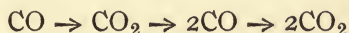

one of which is retained in the cycle while the other is removed to a gas-holder. Nitrogen is eliminated by passing the first portions to waste, or alternatively the apparatus may be filled with carbon dioxide at the outset.

### Concentration of Carbon Dioxide from Mixtures with other Gases

(1) **By means of Water under Pressure.**—Reference has already been made under the manufacture of hydrogen, to the removal of carbon dioxide: (a) from water gas which has been passed over a heated catalyst and contains some 30 % carbon dioxide, in the B.A.M.A.G. continuous catalytic process (p. 159); (b) from blue water gas containing some 5 % carbon dioxide, as a preliminary to fractionation in the Linde-Frank-Caro process (p. 172). Although the recovery of carbon dioxide is not necessarily carried out, it is easily realized on the release of the water from the scrubber, when most of the carbon dioxide is disengaged, accompanied by some sulphuretted hydrogen together with small quantities of nitrogen, hydrogen, carbon monoxide, etc. The utilization of such carbon dioxide for the production of ammonium carbonate, cf. B.P.s of the Badische Co. 23939/14 and 24042/14, when the hydrogen is being produced by the continuous catalytic process for the synthetic manufacture of ammonia, is interesting, the quantity of carbon dioxide being more than sufficient for the saturation of the ammonia simultaneously produced (cf. p. 215). Another similar process consists in the preliminary production of ammonium

carbonate and conversion into ammonium sulphate by interaction with gypsum, thus avoiding the use of sulphuric acid (Badische Co., B.P. 27962/13).

For other references to this subject cf. "Purification of Hydrogen," p. 207.

**(2) By the Alternate Formation and Decomposition of Alkali Bicarbonates in Solution.**—Some reference to the use of ammonium hydroxide and of sodium and potassium carbonates for this purpose has been made on p. 210. In the Claus process (*q.v.*) ammoniacal liquor is used, carbon dioxide being subsequently expelled without noteworthy loss of ammonia by heating to about 90° C. The process most generally used, however, is that depending on the use of sodium or potassium carbonate solutions. In view of its greater solubility and consequent greater absorptive power, potassium carbonate is usually employed in preference to the corresponding sodium salt. An important consideration in the economics of such a process lies in the proper recuperation of the large quantities of heat involved in changing the temperature of the liquor passing round the cycle. In order to avoid this troublesome point the lye may be maintained at constant temperature and the dissociation controlled by variation of pressure. Since, however, the exact procedure is largely conditioned by the particular method of obtaining the dilute carbon dioxide, further details will be given under the different processes.

**(3) By Liquefaction.**—According to Leslie (B.P. 11902/06) cf. also Windhausen, D.R.P. 45102/87, carbon dioxide is separated from furnace gases by compressing, drying, and subsequently cooling the gases to a low temperature. The carbon dioxide separates out in the liquid state while the other gases pass out through a heat-interchanger. Reference to p. 258 will indicate the partial pressures of carbon dioxide which must be attained before any liquefaction can ensue.

**Production and Concentration of Dilute Carbon Dioxide from Products of Combustion.**—Attention has already been paid, under the manufacture of nitrogen, to the production of a mixture of carbon dioxide and nitrogen free

from carbon monoxide, hydrogen and oxygen. For some uses further treatment is unnecessary, but when pure carbon dioxide is required for purposes of liquefaction, etc., a process somewhat as follows is adopted, depending on the cyclic alkali bicarbonate system proposed by Ozouf in 1865, and first applied technically by Luhmann.

The starting material is usually coke, which is burnt with a mechanical stoker or with other precautions to ensure regular combustion with the minimum excess of air, or alternatively first gasified in a producer, the resulting air producer gas being burnt with a secondary air supply in a combustion chamber (cf. Schmalotta, *Z. angew. Chem.*, (1900), 1284). In the former case secondary air may be admitted behind the bridge of the fire-box to remove any hydrogen, carbon monoxide, and sulphuretted hydrogen. The complete conversion of the last mentioned impurity to sulphur dioxide is particularly important since it would otherwise accumulate in the potash lye with deleterious effect. In either case the heat of combustion is employed for heating a boiler containing potash lye, to which plant we shall have occasion to refer presently. Theoretically, with just sufficient oxygen for complete combustion, the carbon dioxide content of the flue gases should be some 20 % ; in practice about 16 % is realized. After passing through a water scrubber, where dust and sulphur dioxide are removed and which may be packed with lumps of limestone, the temperature of the washing water being about 40° C., the cleansed and cooled gases enter the absorber which may take the form of a coke tower, a suitable capacity of which is some 10 ft<sup>3</sup>/lb. carbon dioxide/hour according to Goosmann, or of chambers fitted with baffles and dashers or of such chambers followed by a tower. Counter-current scrubbing with potassium carbonate solution, usually containing about 15–20 grams K<sub>2</sub>CO<sub>3</sub>/100 grams solution, is carried out, the temperature of the liquor being about 30–40° C. Only about half the carbon dioxide is absorbed, the exact amount depending on the efficiency of the absorption arrangements, the rest passing to waste with the nitrogen

which it is heated; the spent lye flows back through the second heat-interchanger and a cooler to the absorber.

**The Production and Transport of Liquid Carbon Dioxide.**—Before liquefaction, carbon dioxide must be dried thoroughly, and this is usually accomplished by passing the gas through drying chambers packed with granular calcium chloride, either at the ordinary pressure or after the first stage of compression. In order to avoid introduction of moisture in the second or further stages of the compression, glycerol may be used for the internal lubrication of the pump, being subsequently separated. A balancing gas-holder is used before the compressor and should be of the annular water-channel type in order to minimize loss of carbon dioxide by solution.

Liquid carbon dioxide is transported in cylinders which may hold about 25 or 66 lbs. On account of its very high coefficient of expansion, great care must be taken in filling the cylinders to ensure that the proper charge is not exceeded and that the cylinder shall not be exposed to the sun or hot situations.

The question of the degree of filling is discussed very fully by Stewart (see p. 44), who recommends a filling of 62 % by weight of the water capacity or 38.8 lbs. carbon dioxide per ft.<sup>3</sup> of cylinder space, assuming a maximum possible temperature of 49° C.

The recommendations of the British Parliamentary Committee on the Manufacture of Compressed Gas Cylinders (1895) are that the maximum charge shall be 47 lbs./ft.<sup>3</sup> for this country and 41.7 lbs./ft.<sup>3</sup> for the tropics, while a test pressure of 224 atms. is specified. The German railway regulation of 1 kilo./1.34 litres corresponds with the higher figure. Absence of air in the cylinders is important since each per cent. of air involves an increase in pressure of the order of 4-5 atms. at temperatures between 40° and 60° C.

**The Production and Transport of Solid Carbon Dioxide.**—In order to avoid the inconvenience of handling and the expense of transport of cylinders, the weight of which is of the order of five times that of the liquid carbon dioxide

itself, the substance is sometimes sent from the works in the solid state\* for use when consumption is to be more or less immediate and the distance of transport is relatively small. The carbon dioxide snow is compressed in wooden moulds.

### Applications of Carbon Dioxide

(a) **In the Solvay Ammonia-soda and the Claus-Chance Sulphur Recovery Processes.**—One of the most important applications of carbon dioxide is in connection with the manufacture of sodium carbonate, both by the old Leblanc process and by the newer ammonia-soda Solvay process. We will deal first with the latter process. The dilute carbon dioxide gases, from special kilns and containing some 30 % carbon dioxide, are used without concentration. The process consists in the double decomposition of sodium chloride and ammonium bicarbonate with the production of ammonium chloride and sodium bicarbonate. Ammonia is first passed into saturated brine and the solution then saturated with carbon dioxide in a tower or other absorber at a temperature of 25–30° C. With the high towers which are often employed, the hydrostatic head of brine may cause a pressure of some 2 atms. on the gases entering at the bottom. Conditions are so adjusted that the sparingly soluble sodium bicarbonate separates out; the ammonia is recovered from the solution by boiling with lime. The bicarbonate is decomposed by calcination, the gases, containing in practice some 50 % carbon dioxide, being collected and returned to the cycle.

The Claus-Chance process has been used to some extent in connection with the Leblanc process and consists in the recovery of the sulphur from the "vat waste" (mostly calcium sulphide) by treatment while suspended in water with gases containing carbon dioxide, when calcium carbonate and sulphuretted hydrogen result.

(b) **In the Manufacture of Artificial Mineral Waters.**

\* Solid carbon dioxide is conveniently prepared in the laboratory by tilting a cylinder so that the valve delivers liquid, binding a canvas bag over the aperture and releasing the liquid, preferably in a series of jerks.

and oxygen. The saturated lye now passes to the boiler through a heat-interchanger in counter-current to the hot lye leaving the same. This boiler, as stated above, is heated, to a little above  $100^{\circ}$  C., by the combustion from which the carbon dioxide results. After giving up its carbon dioxide, the hot spent lye is taken first to the heat-interchanger and then through a cooler to the absorber again. The moist carbon dioxide leaving the boiler is cooled by a system of coils traversed by water, the condensed moisture being returned to the boiler. The heat of condensation of the steam may also be utilized for heating up the saturated lye.

Instead of using potassium carbonate, it is possible to operate with a solution of sodium carbonate containing *e.g.* 6 grams  $\text{Na}_2\text{CO}_3/100$  grams solution, but the results are less favourable. Further, as in the Sürth process (*vide infra*), the variation in the carbon dioxide content of the lye may be produced by alteration of pressure at constant temperature. It has been found that the addition of froth-producing substances, such as soap, is beneficial both as regards the absorption and the disengagement of the carbon dioxide. According to some systems, producer gas is used, part being burnt under the lye boiler and part in a gas engine providing the necessary power, the carbon dioxide from both combustions being utilized.

Carbon dioxide produced by concentration in this way has usually a high degree of purity.

**Sürth System.**—In this instance the exhaust gases from an internal combustion engine are used as a source of carbon dioxide, the engine providing the power required for the concentration process. Working in this way, the combustion is under exact control. Using suction gas *e.g.* of the percentage composition—

Hydrogen	..	..	..	15.0
Carbon monoxide	..	..	..	27.0
Carbon dioxide	..	..	..	5.5
Methane	..	..	..	0.5
Nitrogen	..	..	..	52.0

and diluting with air to, say 30 C.H.U. net calorific value per ft.<sup>3</sup> (cf. p. 346), the percentage of carbon dioxide in the water-free product would be some 16 %. The sensible heat of the exhaust gas is utilized by passage through a boiler in which the saturated lye is heated; the cooled gases, after traversing a scrubber, are compressed to about 5 atms. and enter the absorber which is fed with potash lye at about 100° C. As the lye leaves the absorber, its pressure is released to atmospheric, and on entering the boiler carbon dioxide is disengaged. No heat-interchangers are used, and apart from losses, no temperature changes occur in the lye. It is stated that a fuel consumption of  $\frac{1}{2}$  to  $\frac{3}{4}$  lb. coke per lb. carbon dioxide produced is sufficient.

**Production and Concentration of Dilute Carbon Dioxide from Lime-kiln Gases.**—This method of manufacture of dilute carbon dioxide is usually employed in connection with the manufacture of sodium carbonate by the "ammonia-soda" process. For this purpose it is advisable that the concentration of carbon dioxide in the gases should not fall below 30 %, consequently the kilns are made very large. In order to effect fuel economy the kilns are generally internally fired by coke mixed with the limestone, usually in the proportion of about 1 : 7, the carbon dioxide from the combustion being also utilized. In some cases, however, the kiln is heated by gas from a separate coke producer, the gas being burnt in the kiln by the admission of secondary air. When required for use in the dilute state the gas is freed from dust in a plate washer or in a coke scrubber. The use of magnesite results in a higher carbon dioxide concentration on account of the lower decomposition temperature of this carbonate as compared with limestone.

In order to effect concentration of the gases, similar arrangements to those for dealing with products of combustion are usually adopted. The kiln gases pass through a heat-interchanger to a coke scrubber and then to the absorption towers. The saturated lye traverses a second heat-interchanger in counter-current to the lye leaving the boiler and then passes through the heat-interchanger mentioned above to a boiler in

—In this important application of carbon dioxide the pure gas is required, and, for reasons to which reference has been made, liquid carbon dioxide is now usually employed in preference to the gas generated by the action of acids on carbonates. The gas is generally taken from a gas-holder and forced by a pump into a saturator vessel of gun metal lined with tin, into which water is also pumped at the same time.

Any required additions such as sodium carbonate, syrups, etc., are made to the individual bottles which are then filled with the water saturated with carbon dioxide at the prescribed pressure, means being provided for the escape of air. Complete expulsion of air is important since its presence causes the mineral waters to become "flat" rapidly on opening. According to Mitchell (*Thorpe's "Dictionary of Applied Chemistry,"* 1912) the actual pressure in unsweetened mineral water bottles is usually 45–55 lbs./in.<sup>2</sup> corresponding to a bottling pressure of 120 lbs./in.<sup>2</sup>. In the case of lemonade and the like the water is saturated at only about 60–80 lbs./in.<sup>2</sup>. Soda water siphons are bottled at a pressure of 150 lbs./in.<sup>2</sup>.

**(c) In Refrigeration Plant.**—Carbon dioxide is extensively used in refrigeration plant, especially on board ship; the chief advantages in comparison with ammonia, which gives a somewhat more efficient cycle for normal refrigeration temperatures, are the small dimensions of the compressor, the relative absence of danger and nuisance from leakages, the use of copper tubing and the smaller cost of the carbon dioxide. Carbon dioxide plants are capable of working efficiently to a lower temperature than ammonia plants. The small sized compressors are generally constructed of bronze. In view of the high working pressure, the glands on the cylinders are usually sealed with oil maintained at a pressure slightly higher than that of the gas, leakage being thus entirely eliminated at these points.

**(d) Other Applications of Carbon Dioxide.**—Among the many uses of carbon dioxide may be mentioned the following.



The use of carbon dioxide for the compression of fluid steel in the ingot moulds was introduced by Messrs. Krupp, the liquid carbon dioxide serving as a convenient means of generating enormous pressures.

Experiments have been carried out recently (cf. *J. Soc. Chem. Ind.*, (1918), 224 R) on the use of carbon dioxide for the destruction of pests in grain by forcing the gas into the air-tight silos in which the grain is stored; some 14 ft.<sup>3</sup> of carbon dioxide are sufficient for the submersion of 1 ton of grain. According to Dendy (*Nature*, **103**, (1919), 55) air containing 20 % carbon dioxide is more effective than pure carbon dioxide, the spontaneous accumulation of carbon dioxide in an air-tight silo being sufficient.

Carbon dioxide is employed for fire extinction, usually in the form of an aqueous solution produced when required by the action of sulphuric acid on an excess of sodium carbonate solution in a special generator.

Liquid carbon dioxide has been applied as a source of motive power for torpedoes and the like; for operating pneumatic railway signals in outlying districts, thus avoiding the transmission of compressed air over long distances; for refloating sunken ships, etc. Liquid carbon dioxide is also used extensively for carbonating, clarifying and raising beer. In the raising operation, the cylinder is fitted with a reducing valve, the low pressure side being connected to the barrel, keeping the beer saturated with carbon dioxide in addition to avoiding the necessity for pumping. Other applications are the protecting of wines from moulds; the synthetic production of salicylic acid from phenol (*Chem. Trade J.*, **62**, (1918), 337); the manufacture of white lead; the decomposition of calcium or strontium sugar compounds in sugar refining; the precipitation of pure alumina from sodium aluminate solutions produced from bauxite or cryolite, pure alumina being precipitated and sodium carbonate remaining in solution; the manufacture of bread; the production of carbonates, etc.

An interesting application of carbon dioxide is in the production of formates by interaction with hydrogen in the

presence of a catalyst (cf. Bredig and Carter, B.P. 801/15, also *Ber.*, **47**, (1914), 541; *Chem. Zeit.*, **39**, (1915), 72). According to these authors potassium formate may be produced by vigorous agitation of a 5 % aqueous solution of potassium bicarbonate containing some 0.75 % by weight of platinum black, with hydrogen at a pressure of 60 atms. and at a temperature of 70° C. For the apparatus used in the early investigations see Stuckert and Enderli, *Z. Elektrochem.*, **19**, (1913), 570. Under these conditions a 20 % yield of formate is obtained. The same effect is produced by treating a solution of borax with carbon dioxide and hydrogen simultaneously or, alternatively, calcium carbonate may be treated with hydrogen in the presence of platinum black with the production of calcium formate. B.P. 9762/15 relates to the production of the free acid by the interaction of water, hydrogen and carbon dioxide. A similar combination may be induced by the action of sodium amalgam on an aqueous solution of carbon dioxide (cf. Waygouny, *J. Soc. Chem. Ind.*, (1916), 736; Kolbe and Schmidt, *Liebig's Annalen*, **119**, (1861), 251).

Carbon dioxide has some antiseptic properties and is used for the sterilization of milk and organic liquids. It is used therapeutically for baths either in presence or absence of water vapour, its action being to induce perspiration; also in aqueous solution. The gas is used for the destruction of vermin, such as rats, etc. On mixing carbon dioxide to the extent of 5–8 % with acetylene, the smoky character of the flame is lessened.

**Estimation and Testing of Carbon Dioxide.**—Carbon dioxide is perhaps the easiest of all gases to estimate. When present in small quantities it is readily recognized by its action on lime-water or baryta solution. It is usually estimated by absorption in caustic soda solution. In very small amount, e.g. as in the air, it may be determined by passing through excess standard baryta solution and titrating back with oxalic acid, using phenolphthalein as indicator. One of the chief needs for estimating carbon dioxide is in connection with flue gases, and many forms of automatic

apparatus depending both on absorption with caustic soda and also on physical methods (cf. p. 33) have been devised for this purpose. Space will not permit of a full description of these methods here, but reference may be made to Lunge's "Technical Gas Analysis," 1914.

Commercial liquid carbon dioxide is examined by withdrawing a sample of gas from the inverted bottle. The content of permanent gases (air, carbon monoxide, etc.) is found by absorption of the carbon dioxide by alkali. An approximate estimate of the air content of a cylinder may be obtained by determining the air contents of the first and last portions of the gas delivered from the upright cylinder (Lunge, *loc. cit.*). According to Werder (*Chem. Zeit.*, (1906), 1021) the absence of empyreumatic substances may be judged by the smell and taste; at least 98 % of the gas should be absorbed by alkali; the carbon monoxide content should not exceed 0.5 %; the gas should be free from sulphur dioxide and oxides of nitrogen, and should not decolorize potassium permanganate solution or give a precipitate with silver nitrate solution.

#### REFERENCES TO SECTION IX.

- Goosman, "The Carbonic Acid Industry." Chicago, 1907.  
Kausch, "Die Kohlensäure, ihre Herstellung und Verwendung." Hanover, 1909.  
Thorpe, "A Dictionary of Applied Chemistry." London, 1912. Articles on "Carbon Dioxide" and "Mineral Waters."  
Lunge, "Sulphuric Acid and Alkali," vol. iii. London, Third Edition, 1911.  
Stewart, "The Physical Properties of Carbonic Acid and the Conditions of its Economic Storage for Transportation," *Trans. Amer. Soc. Mech. Eng.*, 30 (1908), 1111.

## SECTION X.—SULPHUR DIOXIDE

**Properties of Sulphur Dioxide.**—Sulphur dioxide is a colourless gas with a very characteristic and pungent odour. It occurs in volcanic gases and in very small traces in town air, being chiefly derived from the iron pyrites present in coal. The chief physical properties of this easily liquefiable gas will be found in Tables 12 and 13, pp. 53–6.

Sulphur dioxide dissolves in water to a considerable extent with evolution of heat, the solubility amounting to 47·3 volumes of gas measured at N.T.P., at 15° C. and 1 atm. pressure, including water vapour, equivalent to 12·16% by weight. Other values are given in the following table:—

Temperature °C... ..	0	10	15	20	30	40
C.c. of gas (measured at N.T.P.) dissolved by 1 c.c. of water under a pressure of 1 atm. in- clusive of water vapour	79·8	56·6	47·3	39·4	27·2	18·8

Solid hydrates are formed with water under suitable conditions, 9–15 molecules of water being linked up. The aqueous solutions decompose very slowly at the ordinary temperature with the final production of sulphur and sulphuric acid, the action being rapid in sealed tubes above 160° C. (Jungfleisch and Brunel, *Comptes Rend.*, **156**, (1913), 1719). The gas is soluble to a considerable extent in sulphuric acid, one volume of which dissolves about 58 volumes of sulphur dioxide at ordinary temperatures; it is also dissolved by mineral oils, the solutions, if dry, having no action on metals.

According to von Wartenberg (*Z. anorg. Chem.*, **56**, (1908), 320) sulphur dioxide undergoes no appreciable dissociation at 2200° absolute; cf. also Ferguson, *J. Amer. Chem. Soc.*, **41**, (1919), 69. A slight decomposition takes

place at the ordinary temperature under the influence of light, sulphur and sulphur trioxide being produced.

The most characteristic chemical property of sulphur dioxide is its action as a reducing agent, itself suffering oxidation to sulphuric acid; thus potassium dichromate is reduced to chromic sulphate. In some cases, however, it behaves as an oxidizing agent, thus Smythe and Wardlaw (*J. Soc. Chem. Ind.*, (1915), 797) found that titanium trichloride and stannous chloride were oxidized by sulphur dioxide in warm, strongly acid solution; the intermediate formation of thionyl chloride is suggested as an explanation.

Sulphur dioxide has an irritating action on the mucous membrane; according to the Selby Smelter Commission (U.S. Bureau of Mines, Bull. No. 98), 0.0005% sulphur dioxide can be detected by smell, while 0.05 % is practically unendurable. A concentration greater than 0.003 % is injurious to vegetation (Lunge).

When dry, sulphur dioxide has no action on iron even at 100° C., but in the presence of moisture a slight action is observed (cf. Lange, *Z. angew. Chem.*, **12**, (1899), 275, 303, 595). As liquid sulphur dioxide cannot contain more than about 1 % moisture at the ordinary temperature, the action is slight, but in sulphur dioxide refrigeration plants, where a considerable temperature rise occurs in the compression, the action becomes of importance. Liquid sulphur dioxide is miscible in all proportions with sulphuric anhydride, but immiscible with sulphuric acid.

Sulphur dioxide may be obtained in the solid state by evaporation of the liquid under reduced pressure.

#### MANUFACTURE OF SULPHUR DIOXIDE

**General.**—The manufacture of sulphur dioxide in the pure state is, in most cases, a question of concentration of the more or less dilute gases obtained in various ways. Although the only process which appears to be in use at the present time is that of Hänisch and Schröder (see below), it will be well to consider briefly some other methods which have been worked or proposed. One of the earliest used

was the Melsens-Pictet method, depending on the action of concentrated sulphuric acid when dropped into molten sulphur at a temperature of  $400^{\circ}$  C. This process was used by certain French firms. The moist sulphur dioxide was compressed and cooled to about  $-10^{\circ}$  C. when the gas liquefied; any water present served to produce hydrates, sufficiently stable to allow of all the sulphur dioxide being subsequently pumped off (D.R.P. 22365/82). One disadvantage of this method of generating sulphur dioxide is the action of the sulphur on the iron retort, and an improvement consists in employing boiling sulphuric acid in a cast-iron retort with molten sulphur floating on the top. Instead of sulphur, carbon has been used with 91% acid; in this case carbon dioxide and carbon monoxide are simultaneously produced (D.R.P. 196371/08). In B.P. 1427/83 Ramsay proposes the concentration of sulphur dioxide by absorption from the weak gases with sodium sulphite, sodium hydrogen sulphite being produced, which on heating gives off pure sulphur dioxide. According to Hart (B.P. 13950/85) sulphur dioxide is produced by the action of sulphuric acid (S.G. 175) on finely divided iron sulphide at  $200^{\circ}$  C. The Hänisch and Schröder process (patents B.P.s 2621/83, 6404/85 and 6405/85; D.R.P. 36721/86 and 52025/90) relates to the absorption of sulphur dioxide from burner gases by cold water and subsequent expulsion by heat; cf. also Basset, B.P. 20667/13. Bergmann and Berliner (D.R.P. 160940/02) propose to realize the same objective by the alternate formation of  $\text{Ca}(\text{HSO}_3)_2$  and  $\text{Ca}(\text{H}_2\text{PO}_4)_2$  by the action of sulphur dioxide on  $\text{CaHPO}_4$  and subsequent reversal of the reaction by heating to  $100^{\circ}$  C. Moulin and Vandoni (F.P. 432431/10) prescribe the isolation of sulphur dioxide by compression to 30 atms. of gases containing 10–12% of sulphur dioxide followed by cooling to  $0^{\circ}$  C. by means of the cold produced by the expansion of the residual gases in a heat-interchanger. Moore and Wolf, in U.S.P. 1091689/14, advocate absorption in calcium chloride solution at  $0^{\circ}$  C. and subsequent release by evacuation. Similarly, U.S.P. 1145579/15 of Garner and Metals Research

Co., relates to the sorption of the gas in charcoal and B.P. 107589/17 (Kaltenbach) to the use of alcohol for the same purpose.

It has been stated above that the only process in use on any important scale for the manufacture of liquid sulphur dioxide is the Hänisch and Schröder process, which uses dilute burner gases as a source of sulphur dioxide; some account will therefore be given of the possible ways of producing such gases as opposed to practically pure or highly concentrated sulphur dioxide.

### Production of Dilute Sulphur Dioxide

The production of sulphur dioxide in a dilute state is undertaken on a very large scale in connection with the manufacture of sulphuric acid and sulphuric anhydride from iron pyrites, from elementary sulphur or from zinc blende, and would require more space for an adequate description than can be allotted in the present volume. Reference should therefore be made to special treatises on this subject. It will, however, be desirable to mention briefly some of the more important patents from the point of view of the present problem.

According to theory, the combustion of sulphur, using the minimum quantity of air, should give rise to a gas containing 21 % sulphur dioxide, but even when elementary sulphur is used, 7-15 % represents the values realized in practice. If less air is used there is a tendency for the sulphur to sublime as such. With pyrites the concentration is smaller.

Dilute sulphur dioxide may be produced in a variety of ways, *e.g.* by melting zinc blende with zinc sulphate (Pernell, D.R.P. 1351/77); by the combustion of sulphuretted hydrogen (Pernell and Simpson, B.P. 14711/86); by roasting galena with calcium carbonate (Huntingdon and Eberlein, B.P. 8064/96); from "spent oxide," and as a by-product from various manufacturing operations, *e.g.* cement manufacture (Basset, B.P. 12027/12). The use of zinc blende is discussed by Hutin (*Moniteur Scient.*, 7, (1917), 25); the

residue is more valuable than in the case of iron pyrites, but the operations are more troublesome. The gases from pyrites burners usually contain small amounts of sulphur trioxide formed by the catalytic action of the burnt pyrites. A mixture of sulphur dioxide and oxygen was formerly prepared for the manufacture of sulphur trioxide by dropping sulphuric acid into incandescent retorts.

### Concentration of Dilute Sulphur Dioxide

**The Hänisch and Schröder Process.**—This process was first taken up in 1885, an experimental factory being erected by Grillo in Germany, making 12 cwt./diem of liquid sulphur dioxide from gases containing 6 % sulphur dioxide. In 1886, a plant turning out 6 tons/diem, working on zinc blende, was operated in Silesia. According to Molinari a factory should have a minimum output of 8–10 tons/diem for economical working. The usual method of operating the process is as follows: Gases from pyrites burners of concentration about 6 % sulphur dioxide (not below 4 %) are passed through a dust-retaining chamber, then cooled thoroughly and passed to the water absorption towers. Two towers packed with coke and plates are often employed, arranged in series with counter-current circulation of the water. The sulphur dioxide content of the issuing gases is reduced to at least 0.05 %, while the water leaving the first tower contains about 1 % sulphur dioxide. In order to effect the removal of the sulphur dioxide from this weak solution with the greatest economy of heat, the said solution is passed first through a leaden heat-interchanger in counter-current to the mixture of steam and sulphur dioxide leaving the top of the desaturation tower. Leaving this interchanger at a temperature of about 85° C., the liquid traverses a coil immersed in the heated liquid in the sump of the desaturation tower, being further heated, and is then sprayed in at the top of this tower, which, according to D.R.P. 52025/90, contains a series of inclined baffles, steam being injected near the bottom. The liquid flowing out is practically free from sulphur dioxide while the mixture of sulphur



dioxide and steam passes, as explained above, to the heat-interchanger and then to a cooler, the condensed water, containing sulphur dioxide, from both being returned to the middle of the desaturation tower.

A variation is described in D.R.P. 36721/86, according to which the mixture of sulphur dioxide and steam evolved on boiling the dilute liquor, in leaden pans heated by the burner gases, is passed up a tower in counter-current to a stream of cold water. The excess steam serves to heat the cold water practically to boiling point; the hot water passes to a heat-interchanger in counter-current to the liquid entering the boiling-out pans, while the sulphur dioxide leaves at the top, practically dry. In both cases, final drying of the sulphur dioxide is effected by passage up a coke tower, down which concentrated sulphuric acid flows, the re-concentration of the sulphuric acid being accomplished by the waste heat from the pyrites burners. The dry sulphur dioxide then passes to a single-stage bronze pump, where it is compressed to  $2\frac{1}{2}$ –3 atms. which suffices, after cooling, to produce liquefaction; an oil-sealed gas-holder, or other equilibrator, is employed. The liquid sulphur dioxide collects in a large wrought-iron receiver fitted with a relief valve for the nitrogen and oxygen present, which are led back to the absorption tower. The liquid sulphur dioxide produced in this way has often a purity of 99.8 %.

The preparation of aqueous solutions of sulphur dioxide demands no precautions except that it is necessary to cool both the gas and the water.

**Transport of Liquid Sulphur Dioxide.**—Sulphur dioxide is put on the market in glass "siphons" for laboratory use in steel cylinders holding from 12 oz. to 2 cwt., or, in Germany, in tank waggons holding as much as 10 tons of sulphur dioxide, some such waggons having 3 cylinders about 23 ft. long and 2 ft. 3 in. diameter. Cylinders are fitted with bent tubes connected to the inlet valves to deliver either liquid or gas according to the position of the cylinder. These tubes also serve to indicate the correct degree of filling of the cylinder; when the cylinder is erect and the valve opened, no liquid should be ejected.

According to German regulations, the cylinders are tested to 30 atmospheres and the maximum degree of filling is 1 kilo. per 0·8 litres, *i.e.* 78 lbs./ft.<sup>3</sup>, or according to Italian regulations, 1 kilo. per litre, *i.e.* 62·5 lbs./ft.<sup>3</sup> In this country no specific regulations appear to exist, but the practice of a prominent firm manufacturing sulphur dioxide is to adopt a maximum filling of about 70 lbs. sulphur dioxide per ft.<sup>3</sup>, the cylinders being annealed and re-tested (to 30 atms.) at least once a year.

### Applications of Sulphur Dioxide

The various applications of sulphur dioxide may, for the sake of convenience, be discussed under the following headings:—

(1) **Manufacture of Sulphuric Acid, Sulphuric Anhydride and Sodium Sulphate.**—It is unnecessary here to do more than mention the use, on an enormous scale, of sulphur dioxide in the manufacture of sulphuric acid by the chamber process and of sulphur trioxide by the “contact process,” a mixture of sulphur dioxide and air being passed over heated finely-divided platinum supported on magnesium sulphate or asbestos, or over iron oxide. Sulphur dioxide is also used in the manufacture of salt cake (sodium sulphate) by the Hargreaves process, which depends on the action of a mixture of sulphur dioxide, steam and air on sodium chloride at 400–540° C., sodium sulphate and hydrochloric acid resulting.

(2) **Manufacture of Wood Pulp.**—Sulphur dioxide is largely used in the preparation of wood pulp for paper manufacture, by the bisulphite process; liquid sulphur dioxide was formerly used to a great extent in the preparation of the liquor and for bringing up to strength, but now pyrites gases are mostly used.

The process consists in boiling fir or pine in small pieces with calcium bisulphite solution containing excess sulphur dioxide under a pressure of 50–80 lbs./in.<sup>2</sup> until all the incrusting matter is dissolved, and then mechanically separating the cellulose from the residue by washing and

beating. The spent lyes contain sugars which may be fermented with the production of alcohol, it being stated that some 4000 tons of alcohol are produced annually in Sweden in this way. After the bleaching of the pulp, sulphur dioxide is again used for the removal of the last traces of chlorine. It is important that the sulphur dioxide used should be quite free from sulphur trioxide and some manufacturers use brimstone in preference to pyrites on this account; the former procedure has the further advantage of furnishing a stronger gas. To free from sulphur trioxide it is necessary to wash the gases with water.

In the manufacture of bisulphite the well-cooled burner gases are brought into contact with lime or magnesium lime. Various systems are used for effecting this operation (cf. Williams, *J. Soc. Chem. Ind.*, (1913), 457)—(1) the gases are injected at the bottom of vessels through which a slow stream of milk of lime flows; (2) the milk of lime is fed into the upper of two closed tanks fitted with stirring gear, while the sulphur dioxide gases are led into the lower tank and flow to the upper one, being assisted by the reduced pressure produced by a pump attached to the latter—when the lower tank is saturated with sulphur dioxide its charge of liquid is run off and replaced by that from the upper one which is filled up with fresh milk of lime; and (3) one or more towers constructed, *e.g.* of reinforced concrete, and from 60–100 ft. high, are filled with limestone and water is sprayed in at the top while the sulphur dioxide gases are admitted at the bottom—if two towers are used, counter-current working is adopted. The third system has the advantage of using unburnt limestone and of requiring less pressure to effect the passage of the gases.

In each case the liquor passes to storage tanks and is enriched by the gases evolved in the digestion of the wood. The following is a typical example of the percentage composition of such a liquor :—

Calcium oxide	..	..	..	0.98
Free sulphur dioxide	..	..	..	2.65
Combined sulphur dioxide	..	..	..	1.15

(3) **In Refrigeration Plant.**—Sulphur dioxide is used to a considerable extent in refrigeration plant, although, of course, it is much less convenient for general purposes than the commonly employed ammonia. The use of sulphur dioxide for this purpose was originally developed by Pictet, its chief advantages over other substances, such as ammonia, lie in its non-injurious action on food, etc., if escape should occur, its low working pressure and its applicability to conditions where no cooling water is available. On the other hand, a considerably larger compressor capacity is required than is the case with ammonia, for example; sulphur dioxide plants are only used for relatively small installations. Reference has already been made to the action on iron of moist sulphur dioxide when warm; in this connection it is important to avoid, as far as possible, the presence of air in sulphur dioxide systems as formation of sulphuric acid may occur and set up corrosion. Although iron is protected to some extent by an insoluble coating, bronze is often used for the compressors. Sulphur dioxide has some lubricating properties and consequently the use of oil is unnecessary.

(4) **As a Solvent.**—In spite of the relative difficulty of handling a liquid with a high vapour pressure at ordinary temperatures, for such purposes, liquid sulphur dioxide is used in certain extraction operations, the principal application being in the extraction of bones in the manufacture of glue. In the extraction of the fat, sulphur dioxide has the advantage over other solvents of greater penetration of the animal membranes. After this operation is completed, calcium phosphate is extracted by an aqueous sulphur dioxide solution. Sulphur dioxide has been proposed as a substitute for the inflammable carbon disulphide or benzol in oil extraction, but no important technical progress appears to have been made in this direction.

(5) **For Bleaching Purposes.**—Sulphur dioxide is used to a considerable extent as a bleaching agent for delicate fabrics, etc., which would be injured by the action of more drastic agents, such as chlorine. The bleaching action of

sulphur dioxide, unlike that of most other agents, depends not on oxidation but on reduction, resulting in the formation of colourless leuco-compounds, and in being reversible, *e.g.* by the action of light. The gas is more effective than the solution, but its action is favoured by damping.

Among substances bleached by sulphur dioxide may be mentioned wool, silk, straw, cereals (action injurious), oils and their fatty acids (*cf.* Hird and Lloyd, *J. Soc. Chem. Ind.*, (1912), 317).

(6) **As a Disinfectant.**—Sulphur dioxide has strong germicidal properties and is used for the disinfection of rooms (by combustion of sulphur or, more conveniently, in the form of liquid), in beer and wine manufacture, for the preservation of fruit, meat, syrups, etc., in ships for rapid disinfection and for the destruction of rats.

It is also used for the interruption of fermentation in wine, etc., and in the treatment of cutaneous diseases.

(7) **Other Applications.**—Among other applications of sulphur dioxide may be cited its use as an "antichlor," already referred to in the case of wood pulp, *i.e.* the removal of the last traces of chlorine from bleached material; the refining of crude petroleum; the softening of hides in tanning; the extraction of alum from shale, and in sugar manufacture, where sulphur dioxide is passed through the juices after, and sometimes before, their treatment with lime which is converted into the difficultly soluble calcium sulphite, the juice being bleached at the same time. Sulphur dioxide has only a slight inverting action on sucrose. In admixture with carbon dioxide, sulphur dioxide is used for fire extinction, in the manufacture of tartaric acid, etc. The use of sulphur dioxide has been proposed for improving the efficiency of engines by utilizing the heat of the exhaust steam.

**The Estimation and Testing of Sulphur Dioxide.**—Sulphur dioxide is readily detected by its characteristic odour or by its reducing action on potassium dichromate paper, etc., and may be conveniently estimated by titration with standard iodine solution.

According to Haller (*J. Soc. Chem. Ind.*, (1919), 52 T) dilute sulphur dioxide is best estimated by absorbing in caustic soda solution, and, after acidifying strongly with hydrochloric acid, titrating with potassium iodate. Spontaneous oxidation of the sodium sulphite to sulphate is prevented by the addition of a negative catalyst, *e.g.* glycerol, to the caustic soda solution. On titration of an aqueous solution of sulphur dioxide with a strong alkali, such as caustic soda, methyl orange gives the point of conversion of the caustic soda into sodium hydrogen sulphite.

Liquid sulphur dioxide is tested for water by withdrawing a sample of the liquid under pressure and evaporating through tared calcium chloride tubes. Sulphuric acid and lubricating oil are determined in the residue. Arsenic also may be looked for when the sulphur dioxide is to be used in connection with food-stuffs. Carbon dioxide and air may be estimated by bubbling a considerable quantity of the gas through chromic acid solution and examining any gas passing through (*cf.* Lunge, "Technical Gas Analysis," 1914, p. 361).

#### REFERENCES TO SECTION X.

Teichmann, "Komprimierte und verflüssigte Gase." Halle, 1908.

Lunge, "Sulphuric Acid and Alkali," vol. i. London, Fourth Edition, 1913.

Harpf, "Flüssiges Schwefeldioxyd, Darstellung, Eigenschaften und Versendung desselben," Sammlung chem. und chem-techn. Vorträge von Ahrens, Bd. v., 1900.

## SECTION XI.—NITROUS OXIDE

**Properties of Nitrous Oxide.**—Nitrous oxide is a colourless gas with a faint but characteristic odour resembling that of burnt sugar. It is readily soluble in cold water as below :—

Temperature °C. . . . .	5	15	25
C.c. of gas (measured at N.T.P.) dissolved by 1 c.c. of water under a pressure of 1 atm., exclusive of water vapour . . . . .	1·0480	0·7378	0·5443

The gas is found on the market in the form of liquid, the vapour pressure varying with temperature as follows :—

Temperature °C. . . . .		0	10	20	30	40
Vapour pressure in atm.	{ Regnault (1862) Villard (1897)	36·1 30·8	44·8	55·3 49·4	68·0	83·4

Liquid nitrous oxide is very mobile and is colourless. The other important physical properties will be found in Tables 12 and 13, on pp. 53-56.

Nitrous oxide is an endothermic compound—

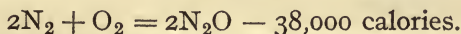

It is, consequently, in a metastable condition at the ordinary temperature. According to Hunter (*Z. physik. Chem.*, **53**, (1905), 441) nitrous oxide is decomposed at 700-900° C. into its elements with the formation of small quantities of higher oxides, especially at the higher temperatures; moisture was found to have little influence. A rough calculation of the equilibrium constant, according to the Nernst Heat Theorem, for a temperature of 2000° C.—

$$-\frac{38,000}{4\cdot571 \times 2273} - 1\cdot75 \log 2273 - 1\cdot4 = \log \frac{p_{\text{N}_2\text{O}}^2}{p_{\text{N}_2}^2 \times p_{\text{O}_2}}$$

indicates that at atmospheric pressure the equilibrium condition corresponds to 0.00013 % of nitrous oxide. Even under the more favourable conditions of a pressure of 1000 atmospheres and the same temperature the equilibrium percentage is only raised to about 0.004 %.

It was observed by Wroczynski (1910) that no decomposition occurred at 420° C. under a pressure of 600 atmospheres.

Nitrous oxide is an energetic supporter of combustion of *e.g.* carbon or sulphur, provided that a sufficiently high temperature for the initiation be first produced. It forms an explosive mixture with hydrogen while a mixture with carbon disulphide burns with a very actinic blue flame. Its use as an anæsthetic was first suggested by Humphrey Davy in 1800; in small amount it produces a kind of intoxication, hence the name "laughing gas."

### Manufacture

**From Ammonium Nitrate.**—Nitrous oxide may be produced from other nitrogen compounds in a variety of ways, *e.g.* by the reduction of nitric acid with a mixture of hydrochloric acid and stannous chloride (Campari) and by the reduction of nitrites with sulphur dioxide, sodium amalgam, etc., but the only method of any practical importance is that depending on the decomposition of ammonium nitrate by heating—

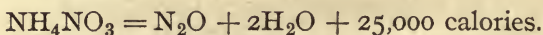

The decomposition begins at 170° C. and is fairly energetic at 215° C. It is important that the ammonium nitrate should be pure, especially as regards chlorine compounds, and great care must be taken not to overheat as the decomposition may become explosively violent.

A description is given by Flagg ("Art of Anæsthesia," 1916) of a plant at the Lakeside Hospital, Cleveland. Ammonium nitrate, in charges of 40 lbs., is heated in one of two aluminium retorts to 200° C. and the resulting gases passed through a cooling coil to a wash bottle containing



potassium permanganate solution in order to remove higher oxides of nitrogen. The nitrous oxide is then washed with caustic soda in a tower packed with coke to remove nitric acid, freed from alkali by passing through sulphuric acid and finally washed with water. The gas passes into a holder and is subsequently either compressed to about 100 atmospheres and liquefied or stored as gas at a pressure of about 100 lbs./in.<sup>2</sup> in pressure vessels from which it is distributed at a pressure of 5 lbs./in.<sup>2</sup> through meters to the operating rooms. The theoretical yield of nitrous oxide is about 4.7 ft.<sup>3</sup>/lb. ammonium nitrate, whereas about 4 ft.<sup>3</sup> are obtained in practice. On this basis 1000 ft.<sup>3</sup> require about 250 lbs. of ammonium nitrate. Instead of aluminium, cast iron may be used as the retort material.

According to Lidoff, a mixture of 2 parts of ammonium nitrate, previously dried at 105° C., with 3 parts of sand is heated to 260–285° C., the resulting gas being washed first with a solution of sodium sulphide or a suspension of iron sulphide and then with an emulsion of ferrous sulphate in concentrated sulphuric acid, to remove nitric oxide. The expensive ammonium nitrate may be replaced by a mixture of ammonium sulphate and sodium nitrate (Smith and Elmore, B.P. 9023/91). Specified proportions of the two salts are mixed and heated to not higher than 230° C. at the beginning of the operation, the temperature rising to about 300° C. at the end. B.P. 11828/13, of Torley and Matter, prescribes the continuous injection of ammonium nitrate either in solution or as solid in convenient form, into a heated reaction vessel containing sand, shot, molten metal, etc., and fitted with a stirrer.

**By Other Methods.**—In B.P. 19074/00 Marston describes the preparation of mixtures of nitrous oxide and nitrogen by passing regulated proportions of ammonia and air freed from carbon dioxide over heated copper. The use of this method for the preparation of nitrogen has been already described, p. 113. Higher oxides of nitrogen are removed by passing through iron shavings, followed by ferrous sulphate solution and then alkali.

By rapidly cooling, at the point of maximum nitrous oxide content, a nitrogen-oxygen flame produced by combustion (not of hydrogen) or by electrical means, Södermann, in F.P. 411785/10, claims the production of nitrous oxide, which is separated from nitrogen by liquefaction after removal of the carbon dioxide. On similar lines is F.P. 415594/10 of Pictet, according to whom a mixture of 55 volumes of oxygen with 45 volumes of nitrogen is forced centrally into a vessel through an oxy-acetylene flame issuing from a flattened annulus. A particular part of the flame is cooled by jets of water which absorbs the nitrous oxide. A yield of 25 % of nitrous oxide is claimed.

### Purification

As indicated above, nitrous oxide is best freed from nitric oxide by scrubbing with ferrous sulphate solution, while chlorine, which may be derived from ammonium chloride present in the ammonium nitrate used in its preparation, can be removed by caustic soda solution or other suitable means. Ammonia may be removed by washing with sulphuric acid. According to Villard, further purification may be effected by fractional distillation of liquid nitrous oxide, any nitrogen going off in the first fraction, or by the formation of a hydrate (below 0° C.) and subsequent decomposition by heating.

### Applications of Nitrous Oxide

The chief use of nitrous oxide is as an anæsthetic, especially for dental operations. The practical application of the anæsthetic property of nitrous oxide is due to Colton and Wells in 1844. It is now administered almost exclusively in conjunction with oxygen since with nitrous oxide alone it is difficult to produce sufficiently lasting anæsthesia without danger of asphyxia. The proportion of oxygen used is from 5-25 % ; usually about 10 % at the beginning with subsequent increase according to the susceptibility of the patient. The effect is very evanescent in any case,

generally lasting about 40 seconds. On the average the time for the production of anæsthesia is a little less than one minute and about one ft.<sup>3</sup> of nitrous oxide is required. Among anæsthetics it is the one most free from constitutional disturbances, but is only suitable for cases in which complete muscular relaxation is not essential.

Nitrous oxide is obtained in steel cylinders containing from about 6 oz. to about 50 lbs. of the liquid, *i.e.* from 3·2–430 ft.<sup>3</sup> of the gas. One lb. of the liquid is equivalent to about 8·55 ft.<sup>3</sup> of gas at 15° C. For purposes of anæsthesia it is important that the nitrous oxide should be free from chlorine, other oxides of nitrogen, combined organic matter, solids, liquids, etc., and should contain at least 95 % nitrous oxide.

A representative sample of the commercial product appears to have a percentage composition somewhat as follows (Baskerville and Stephenson, *J. Ind. Eng. Chem.*, **3**, (1911), 579) :—

Nitrous oxide	..	..	..	96–99
Water	..	..	..	0·15
Carbon dioxide	..	..	..	traces
Ammonia	..	..	..	0·001–0·006
Oxygen	..	..	..	traces
Nitrogen	..	..	..	0·16–3·94

According to the same authors the presence of chlorine and of the higher oxides of nitrogen may be detected by passing some 10 litres of the gas through solutions of silver nitrate and ferrous sulphate. The nitrous oxide may be estimated by passing the dry gas together with hydrogen over heated reduced copper with subsequent reduction of any copper oxide by hydrogen, the water produced being determined in the usual way. In view of the fact that nitrous oxide is an endothermic compound, the stability of the liquid has been the subject of some enquiry (liquid acetylene or even the compressed gas is, of course, a highly dangerous substance owing to its endothermic character).

A propos of the unexplained explosion of a cylinder of

liquid nitrous oxide, Rasch (*Z. für komp. u. flüssige Gase*, (1904), 159) examined the question as follows. By heating platinum or iron wires in the liquid, only local decomposition was observed as a rule when the temperature of the liquid was below  $30^{\circ}$  C., but occasionally explosion occurred, even with the temperature of the liquid as low as  $0^{\circ}$  C. in one instance. Above  $30^{\circ}$  C. the decomposition propagated itself throughout the mass. Electric sparks produced no explosion even at  $80^{\circ}$  C. Generally speaking, detonation only occurred with an energetic temperature rise above the critical temperature of the liquid, viz.  $38.8^{\circ}$  C.; direct heating of the cylinder produced no detonation, although the cylinder burst owing to the high pressure generated.

The possibility of the production of sparks from the presence of suspended solid matter is, however, preferably minimized by always opening the valve with the cylinder in a vertical position, thus avoiding the passage of solid particles through the valve. Further, just as in the case of oxygen, oil should be scrupulously excluded from the valves and connections. As in the case of other liquid gases, special care must be taken with regard to the degree of filling of cylinders owing to the rapid increase in volume of the liquid with temperature. Reference to p. 45 will indicate the permissible content of a given vessel.

## SECTION XII.—ASPHYXIATING GASES

**Introduction.**—During the war the manufacture and use of asphyxiating gases attained such proportions that a book dealing with industrial gases would be incomplete without a brief reference to this branch of the subject.

Although one hopes that the production of the various gases will never be revived for like purposes, there is no doubt that the knowledge gained as regards the technical preparation and properties of many substances previously unknown except to the few will prove to be of signal service in the industries, particularly in the realm of organic chemistry. Further, a number of the substances may be found useful for such purposes as the extirpation of various pests harmful to vegetation.

Since most of the gases, such as chlorine, come under subjects treated in other volumes of this series, their preparation cannot be dealt with in any detail; also, in most cases, the published information in this connection is very meagre at present.

**The Development of Gas Warfare.**—The initiation of gas warfare was made by the Germans in April, 1915, consisting in the use of chlorine discharged from cylinders of the liquid, disposed at regular intervals along the front line, with far-reaching effects on our unprotected troops. Emergency respirators were rapidly improvised and the subsequent development was determined by counter-efforts of a defensive and offensive character respectively.

For a proper understanding of the subject it will be necessary briefly to consider the factors determining the success or otherwise of the operations. One of the most important points is the maintenance of a high concentration—from this standpoint 0·1 % is a fairly high concentration

while 0.01 % is quite effective with most gases, *e.g.* phosgene—and this is dependent chiefly on the wind, the velocity of which should be between the limits of say, 4 and 12 miles per hour, and also to some extent on the slope of the country. In order to ensure the safety of the attacking troops, especially as the line may often be very irregular, the wind should approach normality to the general direction of the line. According to Auld (*J. Wash. Acad. Sci.*, 8, (1918), 45), the deviation tolerated by the Germans was about 40° on either side of the normal. The density of the gas is not so important as is sometimes imagined, since dilution to a concentration of the order of 0.1 % occurs very rapidly and the density of such a mixture does not differ appreciably from that of normal air whatever the density of the gas.

Perhaps the most important matters from a practical point of view are (1) the toxicity; (2) the difficulty of providing protection against the gas; (3) the ease of manufacture in the large quantities required; and (4) the convenience of transport. Condition (4) points to the advantage of non-permanent gases, since a given cylinder filled with liquid contains a considerable weight of poison at a relatively low pressure; chlorine, although suitable as regards (1), (3) and (4), was soon found wanting as regards (2), being very reactive and easily absorbed by alkalis, thiosulphate, etc. The most important gas for this type of attack has been phosgene ( $\text{COCl}_2$ ) (cf. p. 252), which while possessing the other desiderata has also the advantage of being only slowly hydrolysed by alkalis. Phosgene is much less irritating than chlorine but has an insidious delayed physiological action. However, absorbents were soon found in sodium phenate and especially in urotropine—hexamethylenetetramine—which two substances in conjunction gave protection against concentrations of 0.1 % when used in the impregnated flannel type of respirator, a valve being provided for exhalation. This type of respirator was soon entirely superseded by the box type, which consisted of a chamber filled with granules of specially activated charcoal

possessing the property of absorbing gases, especially those of high critical temperature in which category practically all the poison gases are to be found. The box is connected to the mouth by means of a flexible corrugated rubber tube ending in a mouthpiece and nosepiece, suitable inspiration and expiration valves being fitted. This type of respirator has the advantage of simplicity combined with effective protection for long duration attacks for practically all the gases used, and is very easily recharged. For short periods concentrations of several percents can be dealt with. Much depends on the previous history of the charcoal, particularly as regards heat treatment, also on the wood from which it has been made. The enclosed oxygen breathing apparatus, while affording an absolute protection, has only a short time of action and is much too heavy and cumbersome.

Further attempts to use cylinders were made in the direction of increasing the concentration, but the cumbersome and vulnerable nature of the equipment, which was an unwelcome addition to the front line trenches, the need for a special corps of operators, the noise produced by the discharge and the danger of part of the attacking line being gassed, led to their almost complete supersedence by poison-charged projectiles. The shells could be placed with accuracy where required and their use made the operations independent of the wind. Gas attacks by shells are best made with concentration over a relatively small area. Hand grenades have also been used to some extent. In addition to substances which are primarily poisonous, considerable use has been made of "lachrymators," *i.e.* substances which attack the eyes, producing weeping, and also the mucous membranes, *e.g.* benzyl bromide, xylyl bromide, chloropicrin ( $\text{CCl}_3 \cdot \text{NO}_2$ ), phenylcarbylamine chloride ( $\text{C}_6\text{H}_5 \cdot \text{N} : \text{CCl}_2$ ). With some lachrymatories a concentration of 0.0001 % is sufficient to affect the eyes seriously. Similar irritants, which are not highly developed lachrymators, may also be used, the best known member of this class being the deadly "mustard gas,"  $\beta\beta'$ -dichloroethyl sulphide ( $\text{CH}_2\text{Cl} \cdot \text{CH}_2 \cdot \text{S} \cdot \text{CH}_2 \cdot \text{CH}_2\text{Cl}$ ). This substance, even in the state of vapour,

has a most extraordinary, inflammatory action on the skin, the more insidious because not immediate, while its after-effects on the eyes and mucous membranes are most serious, blindness often resulting.

Among other substances may be mentioned trichloromethyl-chloroformate ( $\text{Cl.CO.O.CCl}_3$ ) which is poisonous but not lachrymatory, and diphenyl-chloroarsine ( $\text{As}(\text{C}_6\text{H}_5)_2\text{Cl}$ ) which, when suspended in the air, causes very violent sneezing in addition to its lachrymatory and very toxic action. The lachrymatory and irritant substances just referred to, being in most cases liquid, were practically always used in shells or hand grenades; phosgene was also used in shells. Hydrocyanic acid was apparently not employed by the Germans, probably on account of its temporary action if the dose is insufficient to produce death at once and of its easy arrestment; nickel salts or alkalis may be used as absorbents.

The number of substances which have been employed is very large, the element of surprise being one of the most important tactical points.



## PART III.—GASEOUS FUELS

### SECTION XIII

**General Considerations.**—The subject of gaseous fuels is one which is receiving great attention at the present moment on account of its bearing on the question of thermal efficiency in heating processes generally. This matter is of great importance in connection with the conservation of our fuel resources, and particularly at the present time, in connection with the shortage of labour and the restricted supply of oil fuel for industrial operations owing to the reduced tonnage and, during the war, to the demands of the Navy.

The principal possibilities for increased economy are (1) the utilization of low grade coal with high ash content, and other fuel which would otherwise be useless, *e.g.* peat, waste wood, straw and other refuse may be used with some types of producers; (2) the greater ease of effective thermal regeneration with gaseous fuels and the avoidance of the large excess of air necessary with solid fuel, especially when high temperatures are required, enable better thermal efficiency to be obtained in spite of a certain minimum loss of energy in the preliminary gasification of the solid fuel; (3) the recovery of the greater part, about 70 %, of the nitrogen present in the coal, as ammonia, a valuable national asset both for war purposes, in connection with explosives, and also for use as a fertilizer; and (4) the much greater efficiency of the gas engine as a source of power in comparison with the steam engine, at any rate for relatively small plants.

Among other advantages afforded by the use of gaseous fuel, are the much greater ease of control, *i.e.* the adjustment of temperature or of the reducing or oxidizing nature of the atmosphere of a furnace; the possibility of shutting off the

fuel supply immediately when finished with ; the absence of smoke and ash ; and the ease of distribution from a central station.

The success of various high temperature operations of the highest importance is directly attributable to the introduction of gaseous fuels of low calorific value but cheap, burnt in regenerative furnaces, *e.g.* in the open hearth furnace, in the heating of coal gas retorts, etc.

### Fundamental Principles relating to the Use of Gaseous Fuels

In Table 29 are given typical examples of compositions, based on averages of the analyses given by a number of authorities, of the various gaseous fuels, together with some of their more important characteristics with which we shall deal presently.

**Calorific Value.**—An important point in the comparison of gaseous fuels is the question of calorific value.

Reference has already been made to the necessity for discrimination between "gross" and "net" calorific values, and although the latter term has no very precise significance (*cf.* p. 13) its use is convenient in connection with most operations of heating. Observations relating to British and French practice have been made on p. 13 ; in the United States it is usual to use the gross value for the comparison of fuels, while in German and Austrian practice the products of combustion are assumed to be cooled to 100° C., the water remaining as steam.

We shall see, however, that the value of a gas as a fuel cannot be expressed in terms of calorific value alone.

**The Mechanism of Flame.**—The subject of the properties of flames is an extensive one, and we must confine our attention here to a few of the more practical aspects of the question. Usually the most important characteristic of a flame in relation to furnace work is its temperature. The temperatures of particular portions of a flame are best determined by using several thermocouples of different diameter wires,

TABLE 29.

COMPOSITION AND CHARACTERISTICS OF FUEL GASES.

GAS.	APPROXIMATE PERCENTAGE COMPOSITION.						DENSITY. Calculated for the composi- tions given. Lbs. per 1000 ft. <sup>3</sup> at 15° C.	CALORIFIC VALUE PER CUBIC FOOT AT 15° C. Calculated for the compositions given.			AIR THEOR- ETICALLY RE- QUIRED FOR COMBUSTION. Volumes air per unit volume gas.	NET CALOR- IFIC VALUE OF GAS-AIR MIXTURE. C.H.U. per ft. <sup>3</sup> at 15° C.	EXPLOSIVE LIMITS. Percentage of gas in air.
	H <sub>2</sub>	CO	CO <sub>2</sub>	CH <sub>4</sub>	N <sub>2</sub>	Unsat- urated hydro- carbons.		Gross.		Net.			
								B.T.U.	C.H.U.				
Natural gas ..	—	—	trace	$\left\{ \begin{matrix} 79 \\ (C_2H_6) \\ 18 \end{matrix} \right\}$	3	—	1129	627	1021	567	10.53	49.2	5-12
Coal gas ..	48	8	2	32	6	4	566	315	507	282	4.95	47.4	7-21
Coke oven gas ..	48	7	2	31	8	4	555	308	495	275	4.83	47.2	7-21
Blue water gas (coke)	49	42	4	0.5	4.5	—	300	167	275	153	2.22	47.5	12-67
Carburetted water gas	38	27	3	17	5	10	540	300	493	274	4.60	48.7	—
Semi-water gas (no ammonia recovery —bituminous coal)	14	27	4	3	52	—	164	91	153	85	1.26	37.6	—
Semi-water gas (with ammonia recovery —bituminous coal)	26	13	14	3	44	—	156	87	140	78	1.21	35.4	—
Suction gas (antra- cite) ..	15	27	5.5	0.5	52	—	142	79	133	74	1.05	36.1	—
Air producer gas (bi- tuminous coal) ..	5	29	2	2	62	—	131	73	126	70	1.00	35.0	—
Blast furnace gas ..	2	27	9	1	61	—	104	58	102	57	0.79	31.8	36-65

plotting the results and extrapolating for zero thickness of wire.

Turning to factors determining flame temperatures, it is obvious that, assuming the combustion to be adiabatic, the flame temperature will be represented by the following fraction, sometimes termed the calorific intensity :—

$$\frac{\text{Heat of combustion of the components of the mixture}}{\text{Mean thermal capacity of the products per degree C. over the temperature range in question}}$$

neglecting any dissociation at the flame temperature. Even non-luminous flames, however, are far from being adiabatic. According to Callendar (*B.A. Reports*, (1910), 214), 10–15 % of the energy is lost by radiation, the loss increasing with decreasing air supply and consequently increasing size of flame, a maximum of 15–20 % loss being found when a well-defined inner cone is formed.

The radiation is ascribed by most investigators to the intensely vibratory condition of newly-formed compound molecules (of hydrogen and oxygen or carbon and oxygen, which subsequently revert to the condition of ordinary water or carbon dioxide molecules), a gas in the ordinary state being incapable of transmitting radiation. The measurements of Helmholtz (*Beiblätter*, 14, (1890), 589) indicate that the radiation from a carbon monoxide flame is some 2·4 times that from a similar hydrogen flame, for equal volumes of gas burnt. This fact probably explains the greater usefulness of carbon monoxide than of hydrogen as a constituent of semi-water gas for heating purposes, given equal calorific values in the two samples. The radiation from flames is also of considerable importance in connection with the communication of heat to the cylinder walls in gas engines.

An important factor in the transmission of heat from flames to cooler surfaces is the velocity of the products of combustion over the surface. Thus, the high temperature which is obtained with a blow-pipe in comparison with a Bunsen burner is due in a considerable measure to the high

velocity and consequent high degree of turbulence in the gases.

**Calorific Value of Technical Gas-Air Mixtures.**—Reference to Table 29 will show that although a considerable variation exists between the calorific values of the different gases, there is much less variation between the corresponding values for the mixtures of the same with the volume of air required for complete combustion, and since, for most technical purposes, it is almost impossible to avoid the use of a certain excess of air, the differences are still smaller in actual practice.

It must not be forgotten, however, that a small difference in the calorific intensity may make a considerable difference in the efficiency, especially in non-regenerative high temperature furnaces. The calorific intensities are more or less in the order of the calorific values of the gas-air mixtures, although not necessarily so; thus, blue water gas has a higher calorific intensity than coal gas. Calculated values have not been given on account of the variable proportions of air used in practice and the lack of trustworthy data for specific heats at high temperatures.

**Ignition Temperature.**—Mixtures of various inflammable gases with air or oxygen possess, under certain conditions, quite definite ignition temperatures; by ignition temperature is meant the temperature at which combustion, originated at a point, propagates itself rapidly through the mass of the gas. In the exact determination of such ignition temperatures there is considerable difficulty on account of errors, such as those caused by the heating effect due to slower initial combination at a temperature below the true instantaneous ignition temperature. The method used by Dixon and Coward (*Chem. Soc. Trans.*, (1909), 514) was to spark the point at which streams of the two gases, separately preheated to a given temperature, were brought together, and their measurements, which are given below, were criticized by McDavid (*Chem. Soc. Trans.*, (1917), 1003) on the above grounds. To avoid this error and in order to have a stationary volume of gas since the mixture is imperfect with a

streaming method, McDavid allowed a soap bubble of the mixed gases to impinge on a wire electrically heated to a given temperature; his values also will be found below. Alternatively, the time factor can be eliminated by performing the heating by means of adiabatic compression (Falk).

TABLE 30.  
IGNITION TEMPERATURES.

Gas.	Gas + air. °C.		Gas + oxygen. °C.
	Dixon and Coward.	McDavid.	Dixon and Coward.
Hydrogen .. .. .	580-590	(10 % H <sub>2</sub> ) 747	580-590
Carbon monoxide (moist) ..	644-658	931	637-658
Methane .. .. .	650-750	>1000	556-700
Ethane .. .. .	520-630	1062	520-630
Ethylene .. .. .	542-547	(10 % C <sub>2</sub> H <sub>4</sub> ) 1000	500-519
Acetylene .. .. .	406-440	—	416-440
Sulphuretted hydrogen ..	346-379	—	220-235

Ignition temperatures are of importance, particularly in connection with power production, as the modern gas engine depends for its high efficiency on the employment of a high degree of compression with a correspondingly high temperature production owing to the adiabatic compression (cf. p. 346); it is, consequently, necessary for a suitable power gas fuel to be capable of withstanding the required compression without pre-ignition.

**Explosive Limits and the Velocity of Propagation of Explosion.**—The above are important points in the use of fuel gases, the former from a danger standpoint (for values for some of the fuel gases, cf. Table 29), and the latter in relation to questions of back-firing; thus, in burners of the Bunsen type and in injector blow-pipes, it is necessary for the linear velocity of the explosive gas mixture to exceed the velocity of propagation of explosion in the same.

Space will not permit more than an indication of the complex nature of the phenomena of the propagation of gas explosions. Broadly speaking, however, it will suffice to

state that the explosion originating in a tube results in a period of acceleration of the flame, succeeded by a more or less sudden increase of the velocity of propagation to a very high value of the order of 10,000ft./sec. The phenomena, particularly in the preliminary period, depend (1) on the position of the point of ignition, *e.g.* whether near the open or closed end of the tube; (2) on the diameter of the tube, and (3) on the composition of the gas mixture. For further information cf. Mallard and Le Chatelier, *Annales des Mines*, [8], 4, (1883), 524; Dixon, *Phil. Trans.*, A 200, (1903), 315, and other papers.

### Fundamental Principles of the Production of Gaseous Fuels of Low Calorific Value

Starting from the general standpoint that all processes for the complete gasification of coal depend on the action of oxygen, or water, or of both, on the carbon which constitutes the most important part of the coal, it will be well to consider the thermochemical and thermodynamical changes involved.

(1) **Action of Air on Carbon.**—The combustion of carbon takes place either to carbon monoxide or to carbon dioxide or to a mixture of both according to circumstances.

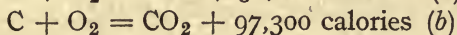
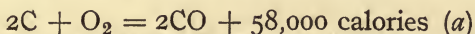

Reaction (a) corresponds to the liberation of 2420 C.H.U./lb. carbon (4360 B.T.U.).

Reaction (b) corresponds to the liberation of 8110 C.H.U./lb. carbon (14,600 B.T.U.).

Now, the general ideal in the production of a fuel gas is to have as high a "cold" thermal efficiency as possible, by which is meant the ratio of the calorific value of the gaseous fuel to that of the corresponding quantity of the solid fuel from which it originated, net values being preferably taken. Stated in other words, the principle is to transform as little potential energy as possible into "sensible" heat

in the gasification process. We shall see later that in some cases it is feasible economically to utilize such "sensible" heat, but in general the gases are used cold, and unless recovered by regenerative operations, the sensible heat liberated in the generator is wasted.

Considering the "cold" thermal efficiency in the above reactions, we find that here the case is very simple since carbon dioxide is incapable of further combustion and consequently the efficiency will vary from

$$\frac{8110 - 2420}{8110} = \frac{5690}{8110} = 0.702$$

when only carbon monoxide is formed, to zero when all carbon dioxide is formed.

If, on the other hand, the gases are utilized in the hot state—supposing, for instance, that the gases leave the generator at a temperature of 800° C., about the usual temperature—we must add to the heat of combustion of the carbon monoxide the thermal capacity of the mixture of carbon monoxide and nitrogen.

Assuming that we are dealing with pure carbon, in which case we should have a gas mixture of  $\text{CO} + 2\text{N}_2$ , and neglecting the increase in the specific heats with temperature, we see that the quantity to be added is

$$\begin{aligned} & 785 \left( C_{p_{\text{CO}}} \times \frac{28}{12} + C_{p_{\text{N}_2}} \times \frac{56}{12} \right) \text{C.H.U./lb. carbon} \\ &= 785 (0.242 \times 2.33 + 0.243 \times 4.66) \text{C.H.U./lb. carbon} \\ &= 1330 \text{C.H.U./lb. carbon.} \end{aligned}$$

The "hot" efficiency therefore equals

$$\frac{5690 + 1330}{8110} = 0.866$$

the difference from unity representing the loss by radiation from the generator.

Up to the present we have been dealing with the ideal case, viz. the production of carbon monoxide only. A



consideration of the equilibrium relations of the reversible reaction

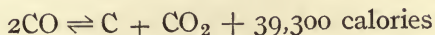

(cf. p. 237) will indicate that this can only be the case (approximately) at temperatures over  $1000^\circ \text{C}$ ., although the fact that the partial pressure is approximately  $0.33 \text{ atm}$ . will hinder the decomposition. According to theory the action of air on carbon should result in the production of a gas containing about 33 % ( $\text{CO} + \text{CO}_2$ ).

The following table shows the equilibria calculated from the experimental data of Rhead and Wheeler and Boudouard (cf. p. 238) for various temperatures taking  $p_{\text{CO}} + p_{\text{CO}_2}$  equal to  $0.33 \text{ atm}$ .

TABLE 31.

EQUILIBRIUM BETWEEN CARBON MONOXIDE, CARBON DIOXIDE AND CARBON AT  $0.33 \text{ ATM}$ . PRESSURE.

Temperature $^\circ\text{C}$ .	..	..	..	600	800	1000
K (from smoothed curve)	..	..	..	14.55	0.124	0.00597
$p_{\text{CO}}$ in atms.	..	..	..	0.120	0.318	0.329
$p_{\text{CO}_2}$ in atms.	..	..	..	0.210	0.012	0.001
$p_{\text{CO}}/p_{\text{CO}_2}$	..	..	..	0.571	26.5	329

An important point in the consideration of the attainment of these equilibria is that discovered by Rhead and Wheeler (*loc. cit.*), namely, that the rate of reaction is much greater—some 166 times at  $850^\circ \text{C}$ .—in the direction of carbon monoxide formation than in that of its decomposition; the consequence is that in passing through the hot zone in the neighbourhood of  $1200\text{--}1500^\circ \text{C}$ . the gases are practically free from carbon dioxide and on subsequent passage through the upper cooler zones, the reaction in the direction of dioxide formation is sufficiently “frozen” to prevent any considerable amount of carbon dioxide being formed.

The practical outcome of these considerations is that from this point of view it is desirable to run the producer at as high a temperature as possible. In practice this desideratum is qualified by the fact that much trouble is caused at excessively high temperatures by “clinking” and by the

increase in losses by radiation, etc. If the fuel used is not pure carbon, but contains considerable quantities of hydrogen, as *e.g.* bituminous coal, the gaseous products will contain appreciable quantities of decomposition products, notably hydrogen and methane, in addition to carbon monoxide, carbon dioxide and nitrogen.

(2) **Action of Steam on Carbon.**—As in the case of oxygen, the action of water on carbon may take place in either of two ways :—

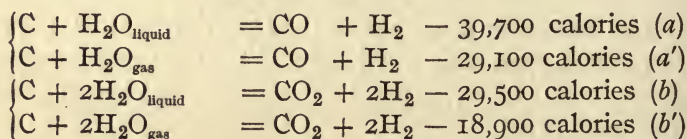

The net calorific values of the resulting gaseous products will be 167 and 102 C.H.U./ft.<sup>3</sup> at 15° C. respectively (cf. Tables 13 and 29) ; it is therefore obvious that the product of (b) is much less desirable as a fuel and, consequently, it will not be considered further. The action differs from that of air in that we have in both the above cases, not an evolution but an absorption of heat.

Thus—

Reaction (a)	involves the absorption of	3310 C.H.U./lb. carbon	(5960) B.T.U.
„ (a')	„ „ „	2420 C.H.U./lb carbon	(4360) B.T.U.
„ (b)	„ „ „	2460 C.H.U./lb. carbon	(4430) B.T.U.
„ (b')	„ „ „	1570 C.H.U./lb. carbon	(2830) B.T.U.

It is therefore evident that the reactions cannot be self-supporting and that the necessary supply of heat must be furnished in some way. External heating of the generator is impracticable, and, consequently, it is found more convenient to adopt the plan of using the fuel itself and the furnace lining as heat accumulators by supplying alternately to the fuel bed an air blast—the “blow” period—and a steam blast—the “make” period, or the “run.”

We have seen above that the combustion of 1 lb. of carbon liberates (a) 2420 C.H.U. if carbon monoxide be formed, and (b) 8110 C.H.U. if carbon dioxide be formed. It will be instructive to make a rough estimate of the thermal balance sheet of the generator. The calculations are made for the sake of indicating clearly the various items in the heat balance sheet rather than for obtaining an accurate evaluation of the coke requirements. For this purpose we will assume the gases both from the "blow" and "make" periods to leave the generator at a temperature of 600° C., and will take no account of the increase in the specific heats with rise of temperature, since the calculations are only approximate and the corrections are not accurately known in all cases. For further simplicity we will neglect the loss by radiation, etc., from the body of the generator; such losses vary with the type of generator, but may be evaluated for specific cases.

*Blow.* (a) *Combustion to Carbon Monoxide.*—Heat of combustion of 12 lbs. of carbon

$$\begin{aligned} &= 12 \times 2420 \text{ C.H.U.} \\ &= 29,000 \text{ C.H.U.} \end{aligned}$$

Heat lost in products of combustion (28 lbs. CO and 56 lbs. N<sub>2</sub>)

$$\begin{aligned} &= 585 (0.242 \times 28 + 0.243 \times 56) \text{ C.H.U.} \\ &= 11,920 \text{ C.H.U.} \end{aligned}$$

Total heat available therefore

$$\begin{aligned} &= 29,000 - 11,920 \text{ C.H.U.} \\ &= 17,080 \text{ C.H.U.} \end{aligned}$$

*Blow.* (b) *Combustion to Carbon Dioxide.*—Heat of combustion of 12 lbs. of carbon

$$\begin{aligned} &= 12 \times 8110 \text{ C.H.U.} \\ &= 97,300 \text{ C.H.U.} \end{aligned}$$

Heat lost in products of combustion (44 lbs. CO<sub>2</sub> and 112 lbs. N<sub>2</sub>)

$$\begin{aligned} &= 585 (0.202 \times 44 + 0.243 \times 112) \text{ C.H.U.} \\ &= 21,120 \text{ C.H.U.} \end{aligned}$$

Total available heat therefore

$$\begin{aligned} &= 97,300 - 21,120 \text{ C.H.U.} \\ &= 76,180 \text{ C.H.U.} \end{aligned}$$

For the present purpose it will be most convenient to consider the reaction in the "run" as being carried out with liquid water and to add on the heat carried into the generator by the steam, assumed at  $100^{\circ} \text{C}$ .

*Make.*—Heat supplied in 18 lbs. of steam, if at  $100^{\circ} \text{C}$ .

$$\begin{aligned} &= 18 (85 \times 1 + 538) \text{ C.H.U.} \\ &= 11,210 \text{ C.H.U.} \end{aligned}$$

Heat absorbed in the gasification of 12 lbs. carbon

$$\begin{aligned} &= 12 \times 3310 \text{ C.H.U.} \\ &= 39,700 \text{ C.H.U.} \end{aligned}$$

Heat lost in the gaseous products (2 lbs.  $\text{H}_2$  and 28 lbs.  $\text{CO}$ )

$$\begin{aligned} &= 585 (3.42 \times 2 + 0.242 \times 28) \text{ C.H.U.} \\ &= 7960 \text{ C.H.U.} \end{aligned}$$

Total loss of heat therefore

$$\begin{aligned} &= 39,700 + 7960 - 11,210 \text{ C.H.U.} \\ &= 36,450 \text{ C.H.U.} \end{aligned}$$

Considering the two cases (a) and (b) separately we find that the ratios of the carbon consumed in the "blow" and "make" periods respectively would be—

$$(a) \quad \frac{36,450}{17,080} = \frac{2.134}{1}$$

$$(b) \quad \frac{36,450}{76,180} = \frac{0.478}{1}$$

or the proportions of the total carbon appearing in the useful product, *i.e.* water gas, would be—

$$(a) \quad \frac{1}{3.134} = 0.319$$

$$(b) \quad \frac{1}{1.478} = 0.677$$

In actual practice the corresponding values are of the order of (a) 0.3, (b) 0.5-0.6.

A simple calculation will indicate that 1 lb. of carbon in the "make" period should produce 63.0 ft.<sup>3</sup> of water gas at 15° C., or conversely, 1000 ft.<sup>3</sup> of water gas should require 15.87 lbs. of carbon in the "make" period. This is equivalent to a total of

$$(a) \quad 15.87/0.319 = 49.7 \text{ lbs. carbon}$$

$$(b) \quad 15.87/0.677 = 23.4 \text{ lbs. carbon}$$

per 1000 ft.<sup>3</sup> of water gas according to the method of combustion in the "blow" period.

The average values found in actual practice for good working are about (a) 50–60 lbs., (b) 32 lbs. coke, or, taking the coke as containing, say, 85 % carbon, (a) 42.5–51 lbs., (b) 27 lbs. of carbon, the figures not including the fuel for raising the steam, this item, if 60 lbs. steam used, being equivalent to some 7 lbs./1000 ft.<sup>3</sup> of water gas in good boiler practice.

If, as usually happens in practice, the blow gases from a generator working on system (a) contain a certain proportion of carbon dioxide, the fuel consumption may be considerably lower than that calculated above.

Theoretical considerations on the above lines would point to the formation of the following volumes of "blow" gases:—

(a) 3200 ft.<sup>3</sup>, (b) 1200 ft.<sup>3</sup> per 1000 ft.<sup>3</sup> of water gas.

The volumes produced in practice are (a) 3000–4000 ft.<sup>3</sup>, (b) 2000 ft.<sup>3</sup>.

Similarly the water requirements should be

$$\frac{15.87 \times 18}{12} \text{ lbs./1000 ft.}^3 \text{ at } 15^\circ \text{ C.}$$

$$= 23.8 \text{ lbs./1000 ft.}^3 \text{ at } 15^\circ \text{ C.,}$$

assuming complete decomposition, which is not realised in practice.

In practice the weight required is about 60 lbs., including, however, the steam for the blowers. If the "blow" be carried out to give carbon dioxide, the theoretical efficiency of the water gas manufacture should be 100 %; in other words, the net calorific value of the water gas should be equal to that of the coke used in its manufacture, assuming no heat losses in the generator, blow gases, etc. In practice, however, the "net cold" efficiency is of the order of (a) 35 %, (b) 70 %, taking the net calorific value of coke at 8000

C.H.U./lb., excluding the fuel for raising the steam, driving the blower, etc. Estimate (a) neglects, of course, the calorific value of the blow gases; this, if counted, would bring the efficiency up to that of (b).

Before leaving this section of the subject, it will be instructive to calculate the effect of preheating the steam. Imagine the incoming steam to be heated from 100° C. to 600° C. at the expense of the issuing water gas—

Heat absorbed by 18 lbs. of steam

$$\begin{aligned} &= 18 \times 500 \times 0.473 \text{ C.H.U.} \\ &= 4260 \text{ C.H.U.} \end{aligned}$$

The total heat loss during the "make" will therefore be diminished by this amount and will amount to

$$36,450 - 4260 \text{ C.H.U.} = 32,190 \text{ C.H.U.}$$

Therefore ratio of carbon consumed in the "blow" and "make" periods respectively is—

$$(a) \frac{32,190}{17,080} = \frac{1.885}{1}$$

$$(b) \frac{32,190}{76,180} = \frac{0.423}{1}$$

Proportion of total carbon appearing in the water gas—

$$(a) = \frac{1}{2.885} = 0.347$$

$$(b) = \frac{1}{1.423} = 0.703$$

Total carbon required per 1000 ft.<sup>3</sup> of blue water gas

$$= \begin{cases} (a) 15.87/0.347 = 45.7 \text{ lbs.} \\ (b) 15.87/0.703 = 22.6 \text{ lbs.} \end{cases}$$

In case (a) this value is considerably lower than in that previously considered.

Thus far we have considered the water gas as being composed of equal volumes of hydrogen and carbon monoxide. In practice this is approximately the case, but a small percentage of carbon dioxide is always present, in amount depending

principally on the temperature of the fuel bed. The reason is to be found in the reversible reaction known as the water gas equilibrium :—

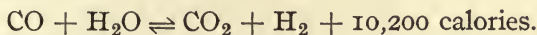

The following table indicates the results of the equilibrium measurements of Hahn (*Z. physik. Chem.*, **42**, (1902), 705 ; **44**, (1903), 513 ; **48**, (1904), 735), the points being taken from a smoothed curve which is extrapolated below 686° C.

TABLE 32.  
HAHN.—WATER GAS EQUILIBRIUM.

Temperature °C.	500	600	700	800	900	1000	1100	1200	1300	1400
$K = \frac{p_{\text{CO}} \cdot p_{\text{H}_2\text{O}}}{p_{\text{CO}_2} \cdot p_{\text{H}_2}}$	0·16	0·32	0·58	0·90	1·25	1·62	1·92	2·16	2·35	2·49

The exact course of the establishment, in technical generators, of the above equilibrium on the one hand, and of the CO, CO<sub>2</sub>, C equilibrium on the other, have been the subject of much discussion. In a discussion of the investigations of Bunte and Harries (*J. Gasbeleucht.*, (1894), 81) on the results of passing steam over carbon at different temperatures, and to which we shall have occasion to refer later, Luggin (*Ib.*, (1898), 713) finds that the water gas equilibrium is established at temperatures between 760° C. and 1000° C., but that the CO, CO<sub>2</sub>, C equilibrium is not attained, the carbon dioxide being always in excess. It was suggested by Haber that the ash content of the coke is operative in facilitating catalytically the attainment of the water gas equilibrium without the carbon itself coming into equilibrium with the carbon monoxide and carbon dioxide. Recently the question has received experimental attention from Gwosdz (*Z. angew. Chem.*, (1918), i., 137), who found that over the range of 560–855° C., a considerable percentage of carbon dioxide—up to 29 %—was always formed with gas coke containing 8·5 % of ash. On the other hand, with almost pure carbon—lampblack with 0·1 % ash—even at 600° C., the water gas contained only 8·6 % carbon dioxide.

Gwosdz's conclusion is that the carbon dioxide is not formed in the primary reaction, but that in the first instance the carbon reacts with water vapour to give carbon monoxide and hydrogen, the establishment of the water gas equilibrium, in the upper and cooler regions of the generator, following by catalysis through the ash of the fuel.

In practical operation of water gas plants, the temperature conditions are continually changing during the "make" period and the duration of this period is so arranged that the average percentage of carbon dioxide does not rise beyond the desired limit.

### (3) Action of a Mixture of Air and Steam on Carbon.

—We have seen above that the action of oxygen on carbon results in an evolution of heat with a consequent tendency to excessive rise in temperature in the producer while the action of water is strongly endothermic, leading to the necessity for discontinuous working and consequent lower efficiency. It is therefore not difficult to see why a combination of the two processes has proved to be the most advantageous method of producing a fuel gas for furnace work and for power generation. Such a combination has the double advantage of avoiding the tendency to "clinkering" and of securing a gas with less inert nitrogen and of higher calorific value than air producer gas; further, owing to the lower temperature, the efficiency is less dependent on recuperation of the "sensible" heat of the products. For a proper understanding of the thermal balance it is convenient to regard the process as being carried out in two generators, disposed side by side, and separated by a partition perfectly permeable to heat. If we imagine the "blow" cycle of the ordinary water gas manufacture to be carried out in one generator simultaneously with the performance of the "make" cycle in the other, the resulting gaseous products being united giving "semi-water gas," it is evident that we have much the same thermal balance as that just worked out for water gas production.

Thus, assuming no heat-interchange, the ratio of the carbon reacting with water to that reacting with air will



be  $1/2 \cdot 134$ , *i.e.* 0.32 of the carbon reacts with water and 0.68 with air. The weight of water per lb. carbon is seen to be

$$\frac{0.32 \times 18}{12} = 0.48 \text{ lb.}$$

Since the volume of 1 lb. of water vapour at  $100^\circ \text{C.}$  is  $26.43 \text{ ft.}^3$ , the volume of this water at  $100^\circ \text{C.}$  will be  $26.43 \times 0.48 \text{ ft.}^3 = 12.7 \text{ ft.}^3$ . Similarly the weight of the oxygen involved is—

$$\frac{0.68 \times 16}{12} = 0.907 \text{ lb.}$$

and the volume  $= \frac{0.907 \times 1000}{84.56} \text{ ft.}^3$  at  $15^\circ \text{C.}$   
 $= 10.7 \text{ ft.}^3$  at  $15^\circ \text{C.}$

or  $10.7/0.21 \text{ ft.}^3$  of air at  $15^\circ \text{C.}$  =  $51.0 \text{ ft.}^3$  of air at  $15^\circ \text{C.}$

or  $66.0 \text{ ft.}^3$  of air at  $100^\circ \text{C.}$

This steam/air ratio corresponds to a partial pressure of

$$\frac{12.7 \times 760}{12.7 + 66.0} \text{ mm. mercury}$$

=  $123 \text{ mm. mercury}$ , *i.e.* a saturation temperature of  $56^\circ \text{C.}$

We have calculated for the case of the action of steam on carbon that a weight of 49.7 lbs. of carbon should produce  $1000 \text{ ft.}^3$  of water gas plus  $3200 \text{ ft.}^3$  of "blow" gases (air producer gas) at  $15^\circ \text{C.}$ , *i.e.* a total of  $4200 \text{ ft.}^3$  of gas. Since these data are applicable to the present case, we see that  $1000 \text{ ft.}^3$  of semi-water gas should result from  $49.7 \times 1000/4200 \text{ lbs.}$  of carbon =  $11.8 \text{ lbs.}$  of carbon. The air requirements per  $1000 \text{ ft.}^3$  of gas should, therefore, be  $11.8 \times 51 \text{ ft.}^3$  at  $15^\circ \text{C.}$  =  $602 \text{ ft.}^3$  at  $15^\circ \text{C.}$ , while the water is similarly evaluated at  $11.8 \times 0.48 \text{ lbs.}$  =  $56.6 \text{ lbs.}$

If the above ideal conditions were fulfilled, the percentage composition of the gas, when operating with pure carbon and neglecting carbon dioxide formation, would be—

Hydrogen	..	..	..	11.9
Carbon monoxide	..	..	..	37.3
Nitrogen	..	..	..	50.8
				100.0

corresponding to a calorific value (net) per ft.<sup>3</sup> at 15° C. of 85.6 C.H.U. On this basis the thermal efficiency would be

$$\frac{85.6}{11.8 \times 8110} = 0.895$$

A somewhat lower saturation temperature than that just calculated would be necessary in practice on account of losses due to radiation, convection, etc. Owing to the diluting effect of products of distillation and partial replacement by carbon dioxide, the carbon monoxide content is not so high in practice. By paying attention to thermal losses, efficiencies of about 80 % may be attained in actual working.

As regards the establishment of the equilibria in the generator, the remarks on water gas apply also to the present case. From a technical standpoint, low carbon dioxide concentration is desirable in order to secure high calorific value and high gasification efficiency. The most important condition for such low concentration is, of course, the maintenance of a high temperature in the fuel bed by keeping down the steam ratio. On the other hand, as we shall see presently, it is sometimes advantageous to sacrifice efficiency of gasification to the recovery of ammonia, by working with a high steam ratio and consequent low temperature in the producer.

Since the manufacture of semi-water gas is usually carried out from bituminous fuel, not from coke, there is often present in the gases an appreciable amount of methane—of the order of 3 %—formed mainly by destructive distillation of the fuel in the upper and relatively cool portions of the generator.

A possible future development of semi-water gas manufacture lies in the substitution of pure oxygen or oxygen-enriched air for air in admixture with the steam (cf. remarks on the possibilities in the future provision of cheap oxygen, p. 94 and p. 106). Using pure oxygen, the resulting gas would contain only combustibles, possessing, in fact, the advantages of water gas without the inherent drawback of intermittent working.

(4) **Action of Carbon Dioxide on Carbon.**—There is still another method of gasifying carbon, namely by the action of carbon dioxide either alone or in admixture with air.

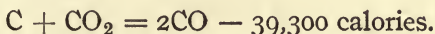

If carbon dioxide alone be passed through the producer, the strongly endothermic nature of the reaction, resulting in an absorption of 3270 C.H.U./lb. carbon (5890 B.T.U.), makes it necessary to use an intermittent "blow" as in water gas manufacture. Using a mixture with air, a balance will be struck as in the case of semi-water gas.

The process was used some years ago in power production on account of the freedom from pre-ignition troubles when using this gas. A portion of the gases from the exhaust of the engine, which operates on very high compression, is returned together with additional air to the generator. The composition of the gas is similar to that of air producer gas.

## TECHNICAL PRODUCTION OF GASEOUS FUELS OF LOW CALORIFIC VALUE

### AIR PRODUCER GAS

**General.**—The gaseous fuel resulting from the action of air on incandescent carbon, and known variously as producer gas, air gas, air producer gas, straight producer gas, etc., was the first form in which carbon was completely gasified for industrial purposes. A simple form of producer with natural draught was introduced by Bischof in 1839, but the first important advance was made by the Siemens Bros., who used producer gas in connection with the principle of regeneration for steel melting, also introduced by them. Natural draught was at first used, but later air injection was adopted and finally the air was injected by means of a

steam blast, air producer gas being no longer used in steel melting.

**General Principles of Operation.**—A clear insight into the principles governing the operation of air producers is afforded by Wendt's investigations (*Stahl und Eisen*, 26, (1906), 1184), which were carried out in a technical generator using bituminous coal as fuel, the bed being 7' 3" deep. For a summary of the results obtained, see the following table, which represents analyses of gases drawn from different zones of the producer at the stated heights above the grate.

TABLE 33.

## WENDT'S EXPERIMENTS ON PRODUCER GAS.

Height above tuyère. Inches.	Temperature °C.	H <sub>2</sub>	CO	CO <sub>2</sub>	CH <sub>4</sub>	N <sub>2</sub>
0	—	—	19.6	8.8	—	71.6
10	1380	—	34.5	—	—	65.5
20	—	—	34.5	0.2	—	65.3
30	1250	0.7	32.7	0.8	0.4	65.4
40	—	11.9	28.9	1.0	2.0	56.2
50	1145	10.0	26.7	2.0	3.8	57.5
60	—	12.3	27.2	2.0	4.2	54.3
Outlet	610	6.4	30.9	1.0	3.2	58.5

Tar was present in the gases at and above the zone 40" above the tuyère. Depth of bed = 87".

An examination of the above analyses will indicate that the equilibrium between carbon monoxide and carbon dioxide is established at or below the point 20" above the tuyère.

Thus, at 20",  $p_{\text{CO}_2} = 0.002$  atm. (cf. the equilibrium values on p. 303), the rate of reaction being very high at the temperature of this zone. Free oxygen is very rapidly removed in the first portions of the fuel; no oxygen was found at any of the points. As the highly heated products of combustion ascend through the fuel bed, their temperature is lowered by contact with the cooler fuel and consequently some reversion to carbon dioxide takes place, but a reference

to p. 303 will show that equilibrium is by no means attained at say 600° C., in the time available.

Further, with the bituminous coal used in these trials, the distillation taking place in the upper regions results in the formation of methane and hydrogen. The composition of the gas produced will vary with the fuel used; with coke the hydrogen and methane will, of course, be lower than with bituminous coal.

The temperature of the producer tends to rise until limited by the increasing losses through radiation and the sensible heat of the gaseous products; the practical limit is set by the trouble of "clinkering" which increases rapidly at high temperatures, and also by the action on the lining of the producer. These difficulties and the low thermal efficiency (cf. p. 302) have led to the almost complete substitution of semi-water gas for air producer gas except in the case of the "blow" period in the manufacture of water gas, where the function of the "blow" is actually to produce a high temperature in the fuel bed and producer lining.

Some plants have been constructed with the deliberate object of working at the maximum possible temperature and combine the production of CO<sub>2</sub>-free gas with the elimination of "clinkering" difficulties by adding limestone to produce a fusible slag with the ash, this slag being tapped off regularly through a slag notch. According to Bone (Thorpe's "Dictionary of Applied Chemistry," 1912) a gas with the following percentage composition and a calorific value of 73 (gross) or 69 (net) C.H.U./ft.<sup>3</sup> at 15° C. is obtained with the Thwaite cupola producer using Lancashire slack coal:—

Hydrogen	..	..	..	5.35
Carbon monoxide	..	..	..	29.0
Carbon dioxide	..	..	..	2.0
Methane	..	..	..	2.05
Nitrogen	..	..	..	61.6
				100.00

Similar results were obtained by Würth and Co. (*Stahl und Eisen*, (1914), 1135) using small coke, the gas containing

34 % CO, 1-2 % CO<sub>2</sub>, and having a calorific value of 84 (gross) or 75 (net) C.H.U./ft.<sup>3</sup> at 15° C. The iron of the ash is stated to be recoverable with the slag as a high silicon, low sulphur, pig iron (cf. also Markgraf, *Stahl und Eisen*, 38, (1918), 703).

**Applications.**—Apart from its use as a fuel gas, air producer gas has some chemical applications, among which may be cited the manufacture of formates, the production of nitrogen, carbon dioxide (*q.v.*).

### WATER GAS

Water gas was first made on an industrial scale in the United States in about 1873, the initiation being due to Lowe. No progress was made in this country until 1888, when a plant was installed at the Leeds Forge operating on the Lowe principle, *i.e.* with the production of carbon monoxide in the "blow" period.

In order to effect a distinction from carburetted water gas, really a mixture of water gas and "oil gas" (*vide infra*), water gas is usually spoken of as "blue water gas" since it burns with a non-luminous blue flame.

**General Principles of Operation.**—From what has been said in the preceding pages it will be evident that the success of water gas production depends on the maintenance of a high temperature in the fuel bed up to the end of the "make" period. The way in which the CO/CO<sub>2</sub> ratio varies with temperature is well brought out by the following experiments carried out by Harries in Bunte's laboratory (*J. Gasbeleucht.*, (1894), 81), and arranged by Luggin (*Ib.*, (1898), 713). In these experiments, steam was passed over wood charcoal heated to different temperatures, on a laboratory scale.

The values of K in the penultimate column are taken from a curve representing the values given in Table 32.

Disregarding certain experimental discrepancies, an approximate agreement is seen to exist between the calculated equilibrium and that observed experimentally except at the lowest temperature.

TABLE 34.  
HARRIES' EXPERIMENTS ON WATER GAS PRODUCTION.

TEMPERATURE. °C.	PERCENTAGE COMPOSITION OF GAS LEAVING THE HEATED CARBON.			PERCENTAGE COMPOSITION OF GAS AFTER REMOVAL OF STEAM.			$\frac{p_{CO} \times p_{H_2O}}{p_{CO_2} \times p_{H_2}}$	Observed.	$\frac{p_{CO} \times p_{H_2O}}{p_{CO_2} \times p_{H_2}}$	From data on p. 309.	GAS VELOCITY. litres/sec.
	H <sub>2</sub>	CO	CO <sub>2</sub>	H <sub>2</sub> O vapour	H <sub>2</sub>	CO					
674	8.41	0.63	3.84	87.12	65.2	4.9	29.8	1.70	0.51	0.9	
758	22.28	2.67	9.23	65.82	65.2	7.8	27.0	0.85	0.76	1.8	
838	28.68	6.04	11.29	54.09	62.4	13.1	24.5	1.01	1.03	3.66	
861	32.77	7.96	12.11	47.15	61.9	15.1	22.9	0.94	1.03	3.28	
954	36.48	11.01	13.33	39.18	59.9	18.1	21.9	0.89	1.11	5.3	
1010	44.43	32.70	5.66	17.21	53.3	39.3	6.8	2.25	1.45	6.3	
1060	47.30	48.20	1.45	3.02	48.8	49.7	1.5	2.12	1.65	6.15	
1125	48.84	46.31	1.25	3.68	50.7	48.0	1.3	2.78	1.81	9.8	
	50.73	48.34	0.60	0.303	50.9	48.5	0.6	0.48	1.99	11.3	

It will be noticed that the action at  $700^{\circ}$  C. results in the formation of very little carbon monoxide and much carbon dioxide, while above  $1000^{\circ}$  C., only comparatively small amounts of carbon dioxide result; the percentage of hydrogen, however, is not greatly affected. An important practical point is the completeness of decomposition of the steam; this is seen to be sufficiently good at  $1000^{\circ}$  C.

Water gas is usually made from coke in practice, and consequently its composition is liable to less variation than is the case where coal, with varying hydrogen content, is employed; for this reason also the methane content is low, viz. from 0.1–1.0%. According to Vignon, the methane content can be increased to some 20% by addition to the coke of lime in large quantity.

The general composition and characteristics of blue water gas will be found in Table 29, p. 297. According to Meade, blue water gas usually contains about 100 to 120 grains of sulphuretted hydrogen per 100 ft.<sup>3</sup>, *i.e.* 0.177–0.194% by volume, and 10 to 15 grains carbon disulphide per 100 ft.<sup>3</sup>, *i.e.* 0.007–0.011% by volume.

### Blue Water Gas Plants

Generally speaking, a blue water gas generator consists of a cylindrical chamber, lined with fire-brick, and provided with a gas-tight charging device at the top and with suitable air and steam admission conduits. It is important that the steam should be dry, while superheating, preferably at the expense of the hot-water gas leaving the generator if the sensible heat of the "blow" gases is being utilized, is an obvious desideratum. Since the steaming is attended with a marked absorption of heat, causing the temperature of the fuel to fall steadily during the run, the rate of reaction rapidly falls off (*cf.* Bunte and Harries, Table 34). It would be advisable continuously to reduce the rate of supply of steam, with improvement both as regards heat losses and the content of carbon dioxide, but this procedure is not carried out in practice.



Owing to the intermittent character of the operations it is necessary to provide a gas-holder as a balancer except, perhaps, when a battery of generators is employed.

Although attempts are made to regenerate heat from the "blow" gases, *e.g.* in carburetted water gas manufacture with the Lowe system (*vide infra*) and from the water gas by superheating the steam, in the Dellwik-Fleischer process, there is no doubt that much more might be done in this direction.

**The Lowe System of Operation.**—The Lowe system, in which the "blow" period furnishes air producer gas, is the one chiefly adopted in this country, since its application to the manufacture of carburetted water gas—for which ultimate object most blue water gas is produced—admits of economic utilization of the "blow" gases. For working on this system the depth of fuel bed must be fairly great; a depth of  $6\frac{1}{2}$  ft., according to Meade, gives the best result, with the coke not more than 3 in. in diameter. The generator is usually some 20 ft. in total height. In most producers the steam is passed alternately up and down, in order to avoid chilling the bottom layers by the steam below the temperature necessary for combustion in the "blow" period; in this way a more uniform distribution is effected. The "blow" and "make" periods in this system of working are generally about 3 and 5 minutes respectively. The fuel consumed is usually about 60 lbs. of coke per 1000 ft.<sup>3</sup> of blue water gas inclusive of the fuel required for raising the steam.

According to Lewes, the percentage composition of the "blow" gases is—

Hydrogen	..	..	..	2·5
Carbon monoxide	..	..	..	29
Carbon dioxide	..	..	..	4
Nitrogen	..	..	..	64·5
				<hr/> 100·0

while Meade gives—

Carbon monoxide	..	..	..	17
Carbon dioxide	..	..	..	10
Nitrogen	..	..	..	73
				<hr/> 100

As stated above, the volume of the "blow" gases is some 3-4 times that of the blue water gas produced, about 30 % only of the carbon of the fuel appearing in the water gas.

**Dellwik-Fleischer System.**—In view of the low thermal efficiency (about 35 %) of the Lowe system when used for the production of blue water gas without regenerative arrangements, the more rational system of burning the carbon dioxide in the "blow" period was introduced by Dellwik about 1900 (cf. Dellwik, *Trans. Iron and Steel Inst.*, (1900), i., 123). It is used extensively on the Continent but only to a limited extent in this country.

In this system of working, a shallow, but frequently replenished, fuel bed—about 3 ft. thick—is employed, in conjunction with a powerful air blast, the "blow" gases containing some 2 % carbon monoxide (Lewes). As in other types of generator, the steam is admitted alternately at top and bottom of the fuel bed, passing through a heat-interchanger before entering the generator, and so being heated by the effluent hot-water gas. On account of the much more energetic liberation of heat in the "blow" period, this occupies only about 1-2 minutes while the run lasts 4-8 minutes.

According to a test carried out by Bone, using coke of 87.4 % carbon content (referred to the dry coke), 34.4 lbs. of the dry coke—30 lbs. carbon—were required per 1000 ft.<sup>3</sup> of blue water gas at 15° C. (exclusive of fuel for raising steam), the average percentage composition being—

Hydrogen	..	..	..	..	49.15
Carbon monoxide	..	..	..	..	42.90
Carbon dioxide	..	..	..	..	3.90
Methane	..	..	..	..	0.55
Nitrogen	..	..	..	..	3.50
					100.00

and the calorific value—

Gross	..	169	} C.H.U./ft. <sup>3</sup> at 15° C.
Net	..	154	

The "net cold" thermal efficiency was 60.5% (excluding the fuel for raising the steam, etc.), 50.5% of the carbon appearing in the blue water gas.

Such high efficiency is, of course, not always realized in common practice.

**Kramer and Aarts Process.**—The Kramer and Aarts process is a modification of the Dellwik-Fleischer process, but differs in the construction and operation of the generator. Twin generators are used, side by side, and are operated as follows:—

The fuel beds, of 5–6 ft. depth, are "blown" in parallel for about 1 minute, a powerful air blast being used. The resulting gases, consisting essentially of carbon dioxide and nitrogen, pass out at the top of the generator, together with secondary air to complete the combustion of any carbon monoxide present, to a regenerator consisting of two vertical shafts arranged side by side, packed with chequer-work and interconnected at the upper end, and then into the atmosphere. The fuel having been raised to a high temperature in this way, steam is admitted at the bottom of one of the fuel beds, passing through the bed, up one shaft of the regenerator and down the other (the valve at the top communicating with the atmosphere being now closed) then down through the second fuel bed and escaping through annular ports just above the grate. In this way the gases from the generator, together with any undecomposed steam, are superheated in the regenerator, and, as relatively little heat absorption is thus demanded in the second generator, very complete decomposition of steam and elimination of carbon dioxide take place at the resulting high temperature, the composition of the gas suffering less impoverishment during the "run" than in other systems. After steaming for some 5 minutes the "blow" is repeated, and then steaming is resumed in the opposite direction from that of the previous "make" operation.

The Kramer and Aarts system has the advantage of removing the gas from the fuel bed, *i.e.* from catalytic influences, at the highest temperature zone, thus preventing carbon dioxide formation by reversal of the water gas

equilibrium, and secures passage of the steam through twice the depth of fuel offered to the passage of the air. In a recent test of a Kramer and Aarts plant by Bone, using coke of 87.2 % carbon content (referred to the dry coke), the following data were obtained :—

Dry coke per 1000 ft.<sup>3</sup> of gas at 15° C. = 28.7 lbs. = 25.0 lbs. carbon, exclusive of the fuel required for raising the steam.

The average percentage composition of the gas was—

Hydrogen	..	..	..	..	45.10
Carbon monoxide	..	..	..	..	43.70
Carbon dioxide	..	..	..	..	3.75
Methane	..	..	..	..	0.50
Nitrogen	..	..	..	..	6.95

and the calorific value—

Gross	..	..	162	} C.H.U./ft. <sup>3</sup> at 15° C.
Net	..	..	149	

The “ net cold ” thermal efficiency was 0.705 (excluding the fuel used for raising the steam). 60.6 % of the carbon in the fuel appeared in the water gas.

Figures are also given by Keable (*J. Soc. Chem. Ind.*, (1918), 644 A); 29.8 lbs. of coke were required per 1000 ft.<sup>3</sup> of blue water gas. Carburetted water gas may be produced with this plant if desired, the oil being sprayed into the second generator.

### Carburetted Water Gas

One of the chief applications of water gas is as an intermediate product in the manufacture of carburetted water gas for the purpose of addition to coal gas. Carburetted water gas is really a mixture of blue water gas and “ oil gas,” meaning by the latter term the products of “ cracking ” petroleum oils at a high temperature. For the production of this mixture, the Lowe system is well suited, and the carburetted water gas in this country is principally made by this system, the best known plant being that of Humphreys and Glasgow, an American firm.

Briefly described, the process is carried out in the following manner. The hot “ blow ” gases, consisting mainly of

carbon monoxide and nitrogen, are led to a "carburettor" down which they pass, a supply of secondary air being admitted at the top. The carburettor consists of a chamber packed with chequer-work, which is heated to a high temperature by the combustion of the "blow" gases. Leaving the carburettor the gases pass up a tall "superheater" chamber about twice the height of the carburettor, also packed with chequer-work, a further supply of air being admitted to complete the combustion of the carbon dioxide; the products finally escape into the stack. During the "run" the blue water gas passes through the chambers in the same direction. Oil is sprayed into the carburettor at the top mostly during the first half of the "run," so as to be swept out before the next "blow"; in passing down this chamber and up the "superheater" the oil vapours are converted into gaseous products by contact with the brickwork, heated to about  $750^{\circ}\text{C}$ .

The mixed gases from the top of the "superheater" are led to sulphuretted hydrogen and carbon dioxide purifiers. The sulphur content is much less than that of crude coal gas, and although naturally variable may be about 100 grains  $\text{H}_2\text{S}$  per 100 ft.<sup>3</sup> (0.16 % by volume); the sulphur is, moreover, mostly in the form of sulphuretted hydrogen which is removable by iron oxide, the final sulphur content ( $\text{CS}_2$ ) being, according to Meade, 10–15 grains per 100 ft.<sup>3</sup>. The composition of the carburetted water gas is naturally dependent on the proportion of oil used, generally about 2–3 gallons per 1000 ft.<sup>3</sup> of carburetted water gas. It is not usual to add more than one volume of carburetted water gas to two volumes of coal gas, in order to keep down the final percentage of carbon monoxide, most town gas containing 15–30 % of carburetted water gas. The coke consumption is usually of the order of 45 lbs. of coke per 1000 ft.<sup>3</sup> of carburetted water gas, inclusive of the fuel for raising the steam. According to Meade (*J. Gas Lighting*, 117, (1912), 211), the coke for the generator is about 37 lbs. coke/1000 ft.<sup>3</sup> of carburetted water gas in good practice. Lewes states that the thermal efficiency of the process may be as high as 80 %, Meade gives 61 %. Table 29 gives a

typical example of the composition of carburetted water gas, the calorific value of which is usually about 300 gross, 275 net C.H.U./ft.<sup>3</sup>.

Originally used as an enricher on account of its high illuminating power when burnt in a batswing burner—according to Meade about 18 C.P. as compared with 14 for coal gas—carburetted water gas is now used principally as a means of coping with “peak” and emergency loads in municipal gas supply stations on account of the ease and speed with which the plant can be started up, and of the small standby costs of producer plant in comparison with coal gas retorts, a bench of which requires about three days for heating up. Carburetted water gas is even used for distribution without admixture in the United States.

Recently, owing to the difficulty of obtaining oil on account of the decreased tonnage and the demands of the Navy, together with the tendency towards the replacement of the illuminating standard by a calorific standard, blue water gas (*i.e.* uncarburetted) has sometimes been added, *e.g.* 20 %, to coal gas. Such addition has previously been regarded with disfavour in this country, where the percentage of carbon monoxide in illuminating gas does not often exceed 16 %, on account of the poisonous properties of blue water gas with its high carbon monoxide content.

The Humphreys and Glasgow plant at the Beckton works of the Gas, Light and Coke Co. produces some 18 million ft.<sup>3</sup>/day of carburetted water gas and consists of twin generators which can be operated in series or in parallel according as to whether the quality or the quantity of the gas is of more importance.

In the Humphreys and Glasgow and other plants, special interlocking devices are used to prevent the formation of explosive mixtures, etc.

The carburetting of water gas may also be performed by the “cold” process, *i.e.* by the addition of benzol, this process being specially suitable when the “blow” gases consist of carbon dioxide and nitrogen only.

Various proposals have been made for combined systems

effecting both destructive distillation of the coal and subsequent complete gasification of the coke with the aid of steam in the lower part of the same generator, the gaseous products being mingled except as regards the "blow" gases from the water gas production.

### Applications of Blue Water Gas

As explained above, the chief application of blue water gas is in connection with the manufacture of carburetted water gas. It is, however, used in large quantities for heating purposes and in particular for the welding of large steel tubes and plates, as its flame is short and of high calorific intensity, slightly greater than that of coal gas. Using preheated air it is even possible to melt platinum. Some care is needed by reason of its poisonous properties and absence of smell, strongly smelling substances such as mercaptan sometimes being added to mitigate this danger. Blue water gas is also used in large and increasing quantities for the manufacture of hydrogen by the Lane and other allied processes, by the B.A.M.A.G. continuous catalytic process, etc. Blue water gas is seldom used in internal combustion engines on account of its liability to pre-ignition, but may be used if the compression is not too high. To a limited extent, blue water gas is used in furnace work, but is not so convenient for general purposes as semi-water gas, cf. also the remarks on p. 298 anent the bearing of high hydrogen content on the radiation from flames. On a pre-war basis blue water gas could be manufactured at a cost as low as  $4\frac{1}{2}d./1000 \text{ ft.}^3$  and carburetted water gas at about  $8d./1000 \text{ ft.}^3$ .

### SEMI-WATER GAS

**General.**—The subject of semi-water gas, by which general term we will denote the products depending on the action of a mixture of air and steam on incandescent carbon, is somewhat complex owing to the variety of the ultimate objects of plants in which the essential reaction is the above.

Generally speaking, semi-water gas plants may be divided into two classes: (1) those operating, usually on bituminous

coal, for the production of a gas which is used directly, in the hot state without any recovery of ammonia or other products, for furnace operations; (2) those operated principally for the production of power.

### General Principles of Operation

Perhaps the most important variables as regards general procedure in the manufacture of semi-water gas are (1) the nature of the fuel; (2) the saturation temperature of the air blast, *i.e.* the ratio of oxygen to steam; and (3) the rate of gasification per square foot of grate area.

(1) **Choice of Fuel.**—The statement already made as to the possibility of utilizing almost any type of low grade fuel in a producer applies particularly to the manufacture of semi-water gas. This, however, should not be taken as meaning that the nature of the fuel has no technical importance; on the contrary, it is a very important consideration in the design and performance of producers.

Of special importance are the caking propensities of the fuel, which determine the tendency to choking and channelling and, if highly developed, make the use of the fuel in a producer out of the question; the nature and quantity of the ash, which affect the difficulty of clinkering and the permissible temperature as determined by the air/steam ratio; and the carbon content, which influences the physical properties of the fuel and the composition of the resulting gases, the calorific value varying with the proportion of volatile hydrocarbons in the fuel.

An adequate treatment of the complex subject of the classification of solid fuels is beyond the scope of the present volume, but a brief indication of the different varieties of coal is desirable. A very complete synopsis of the available literature on the subject of the constitution of coal will be found in a monograph by Stopes and Wheeler, published by the Department of Scientific and Industrial Research, 1918. Many attempts, none wholly successful, have been made to correlate the properties of coals with their compositions.

A classification due to Campbell (*Trans. Amer. Inst.*



*Mining Engineers*, 36, (1906), 324), and adopted by the United States Geological Survey, is given below :—

Group.				C:H ratio.
A.	Graphite	..	..	$\infty$ —(?)
B.}	Anthracite	..	..	{ (?) —30(?)
C.}				{ 30(?)—26(?)
D.	Semi-anthracitic	..	..	26(?)—23(?)
E.	Semi-bituminous	..	..	23(?)—20
F.}	Bituminous	..	..	{ 20 —17
G.}				{ 17 —14·4
H.}				{ 14·4—12·5
I.}				{ 12·5—11·2
J.	Lignite	..	..	11·2—9·3
K.	Peat	..	..	9·3—(?)
L.	Wood, Cellulose	..	..	7·2

According to Seyler's classification the carbon content works out as follows :—

Class	Anthracitic	Carbonaceous	Bituminous	Lignitous
Percentage of carbon	>93·3	93·3—91·2	91·2—84	84—75

the carbon being reckoned on the pure coal substance free from ash and sulphur.

An important characteristic of coals, especially of bituminous coals, is the variation in their properties as regards "caking" or agglomeration on heating in absence of air. The exact relation between this property and the composition is not definitely established; it may, however, be stated that bituminous coals may be classified roughly in the order

non-caking  
caking  
coking

according to the decrease of the carbon/hydrogen ratio.

*Nitrogen Content of Coal.*—The percentage of nitrogen present in coal varies somewhat, but is usually about 1·3—1·5%. This is equivalent to 35—41 lbs. N<sub>2</sub>/ton coal, or 137—158 lbs. ammonium sulphate/ton coal. It is evident that with a possible 70% recovery of this nitrogen the quantities of ammonia capable of production would be very large if any

considerable proportion of the fuel consumed were gasified under suitable conditions. Thus 70 % recovery at 1.3 % nitrogen is equivalent to 96 lbs. ammonium sulphate/ton coal, the value of which sulphate is an important fraction of that of the fuel.

*Sulphur Content of Coal.*—Sulphur is present to the extent of 0.5–2.5 % in coal, partly in combination with the mineral constituents of the ash, *e.g.*  $\text{FeS}_2$ ,  $\text{CaSO}_4$ , and partly in the form of organic compounds. The latter volatilize on heating, but the bulk of the sulphur remains in the coke on destructive distillation.

*Other Deleterious Constituents of Coal.*—Coal contains small quantities of arsenic and phosphorus; arsenic may be present to the extent of some 0.01 % by weight (cf. Wood, Smith and Jenks, *J. Soc. Chem. Ind.*, (1901), 437).

An important point in the choice of fuel for a particular object is the question of tar elimination. The tar produced with different fuels varies not only in quantity but also in quality, the property of chief importance from our point of view being the ease of removal of the fog, which is particularly injurious when the gas is to be used in internal combustion engines owing to its deleterious action by deposition on the valves, etc. Thus, in spite of the small proportion of volatile matter in coke, the tar fog produced in the generator is specially difficult to scrub out. For such reasons, in order to avoid the use of elaborate scrubbers, etc., anthracite is usually employed in preference to the much cheaper bituminous coal in relatively small "suction" power gas plants. Generally speaking, however, bituminous coal is the usual fuel for semi-water gas production on a large scale.

**(2) The Saturation Temperature of the Blast.**—In our preliminary examination of this question we arrived at a saturation temperature of 56° C. as striking the thermal balance for the ideal case considered. In practice, however, it is possible to operate over a considerable range of the oxygen/steam ratio according to the quality of gas required and the degree of regeneration, if any, of the sensible heat carried off by the gases.

A valuable large-scale investigation of the conditions influencing the production of semi-water gas was carried out by Bone and Wheeler (*Trans. Iron and Steel Inst.*, (1907), i., 126 ; (1908), iii., 206), using a Mond type of producer with Lancashire bituminous coal.\* The main results of the investigation are summarized in Table 35.

Among the more important conclusions from this investigation may be mentioned the following: (cf. also synopsis of the same by Bone in his article on Fuel in Thorpe's "Dictionary of Applied Chemistry," 1912):—

(1) The mean final distribution of the carbon of the coal is as follows:—

In the gas .. .. .	92.4 %
,, tar .. .. .	6.3 %
,, ash .. .. .	1.3 %
	100.0

(2) The steam undergoes practically complete decomposition at saturations up to 55° C., above which temperature some steam passes through the fuel though the absolute quantity decomposed per unit weight of fuel increases. This is due to the endothermic nature of the carbon-steam reaction which causes a lowering in temperature in the fuel bed until such tendency is balanced by the falling rate of reaction.

(3) Increasing the depth of the bed beyond 3½ ft. and doubling the rate of gasification have little influence on the quality of the gas.

(4) The degree of saturation has no great effect on the "net cold" thermal efficiency (including the fuel required for raising the steam) except when the saturation temperature exceeds 60° C. Above this temperature a steady decline is observed. The authors conclude that the best compromise between high thermal efficiency and the production of a good furnace gas with high carbon monoxide content is obtained at 45–55° C., consequently 50° C. would appear to be about the best saturation temperature (cf. also

\* For similar experiments cf. also Neumann, *Stahl und Eisen*, 33, (1913), 394.

TABLE 35.

BONE AND WHEELER'S EXPERIMENTS

Average depth of fuel bed .. .. .	3 ft. 6 in.					
Average rate of gasification (day shift) per } hour per producer .. .. . }	22.5 cwt.					
Steam saturation temperature °C. .. .. .	45	50	55	60	70	
Percentage composition {	H <sub>2</sub> .. .. .	11.60	12.35	15.45	15.50	19.75
	CO .. .. .	31.60	30.60	28.10	27.30	20.85
	CO <sub>2</sub> .. .. .	2.35	2.50	4.40	5.10	9.25
	CH <sub>4</sub> .. .. .	3.05	3.00	3.00	3.05	3.45
	N <sub>2</sub> .. .. .	51.40	51.55	49.05	49.05	46.70
Total percentage of combustibles .. .. .	46.2	49.95	46.6	45.85	44.05	
Calorific value, C.H.U./ft. <sup>3</sup> } at 15° C. } Net .. .. .	Gross .. .. .	94.8	94.0	95.2	94.1	92.4
	Net .. .. .	89.8	88.8	89.0	87.9	84.8
Coal used per 1000 ft. <sup>3</sup> of gas at 15° C. Lbs.	15.9	16.0	16.0	15.7	—	
Steam added to blast. Lbs. per lb. coal ..	0.2	0.21	0.32	0.45	—	
Percentage steam decomposed .. .. .	all	all	all	76.0	—	
Total percentage carbon losses (tar, ashes, soot) .. .. .	7.3	7.9	9.15	8.0	—	
Air used per lb. coal. Ft. <sup>3</sup> at 15° C. ..	40.9	40.7	38.77	39.50	—	
Ratio of $\frac{\text{oxygen from steam}}{\text{oxygen from air}}$ in the semi- water gas .. .. .	0.33	0.3	0.42	0.44	—	
Net cold thermal efficiency as in trials,* including steam for blowers .. .. .	0.73	0.718	0.722	0.725	—	
Ditto,* including also steam for the washers	—	—	—	—	—	
Net cold thermal efficiency including fuel for raising the steam for the blast (if boiler efficiency = 70 per cent.), also steam for the blowers and washers .. .. .	—	—	—	—	—	
Ammonia in the gases. Lbs. ammonium sul- phate/ton coal .. .. .	—	—	—	—	—	

\* In the actual trials exhaust steam was

## ON SEMI-WATER GAS PRODUCTION.

7 ft.

11.5 cwt.

60	65	70	75	80
16.60	18.30	19.65	21.80	22.65
27.30	25.40	21.70	18.35	16.05
5.25	6.95	9.15	11.65	13.25
3.35	3.40	3.40	3.35	3.50
47.50	45.90	46.10	44.85	44.55
47.25	47.10	44.75	43.50	42.2
97.7	97.6	93.5	90.6	89.3
91.1	90.6	86.0	82.8	81.3
15.4	15.8	15.0	14.6	14.4
0.45	0.55	0.80	1.10	1.55
87.0	80.0	61.0	52.0	40.0
5.8	7.8	8.1	7.1	8.4
38.98	36.8	36.7	38.9	39.1
0.50	0.62	0.65	0.75	0.80
0.778	0.750	0.727	0.701	0.665
0.715	0.687	0.660	0.640	0.604
0.687	0.655	0.630	0.611	0.578
39.0	44.7	51.4	65.25	71.8

used except at the saturations over 65° C.

Voigt, J., *Gas Lighting*, **109**, (1910), 168). For this temperature, at which it is found possible to operate continuously, the gas has the percentage composition—

Hydrogen	..	..	..	12'35
Carbon monoxide	..	..	..	30'60
Carbon dioxide	..	..	..	2'50
Methane	..	..	..	3'00
Nitrogen	..	..	..	51'55

Attention is drawn to the importance of the fact that when used for regenerative furnaces the gas entering the regenerators should be of such composition, including its moisture content, that no change should be set up by establishment of the water-gas equilibrium (at any rate in the direction of converting carbon monoxide into carbon dioxide by reason of the presence of too much water vapour) at the temperature in question, namely about 1100–1200° C. Thus, the gas obtained at 50° C. saturation temperature of the blast, when saturated with water vapour at 20° C., and having consequently a composition of

Hydrogen	..	..	..	12'1
Carbon monoxide	..	..	..	29'9
Carbon dioxide	..	..	..	2'4
Methane	..	..	..	2'9
Nitrogen	..	..	..	50'4
Water vapour	..	..	..	2'3
				<hr/> 100'0

gives a value of

$$K = \frac{29.9 \times 2.3}{2.4 \times 12.1}$$

$$= 2.37$$

approximately equal to that corresponding to the regenerator temperature (cf. Table 32), and is found to pass unchanged through the regenerator.

(5) The methane content is independent of the steam/air ratio, indicating that its presence is due mainly to destructive distillation.

The actual proportion of steam used in practice will depend, of course, on the moisture content of the fuel, thus, peat may require no addition of steam, while lignite requires

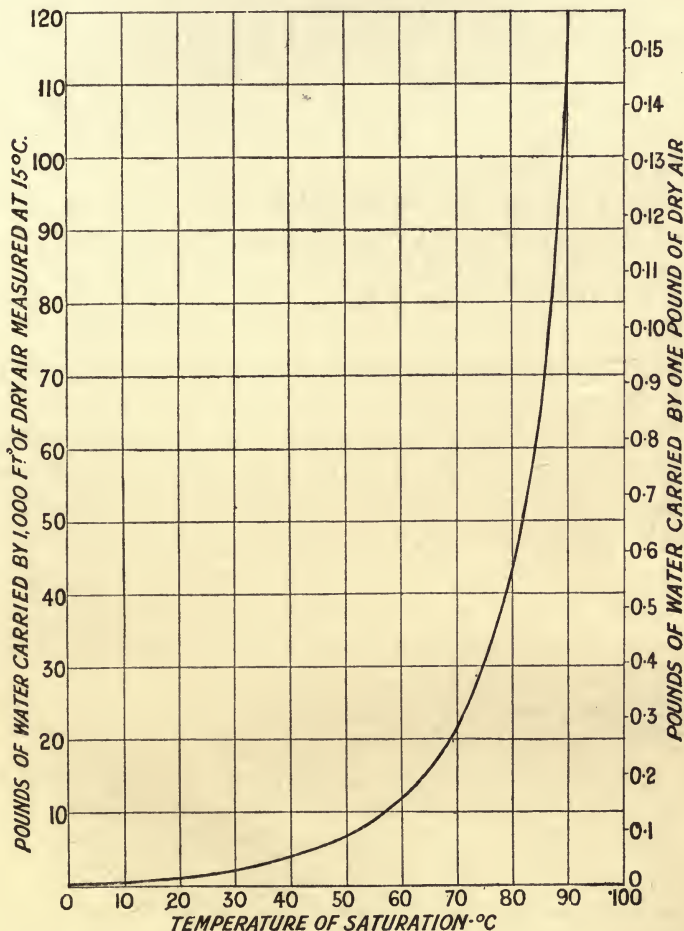

FIG. 23.—Curve giving water content of air blast for saturation at different temperatures.

relatively little. As seen in the production of air producer gas, it is advantageous from the point of view of low carbon dioxide content, to run at a temperature not below  $1000^{\circ}\text{C}$ ., but, on the other hand, high working temperatures involve

greater losses of sensible heat in the gases and of heat by radiation, and also give rise to clinkering troubles. The steam/air ratio will consequently depend on the nature of the ash, its quantity and fusibility, and incidentally on the type of grate, depth of ash, etc. Fig. 23 gives the relation between the saturation temperature and the proportion of steam present in the blast.

For very low grade fuels with high ash content special producers are constructed.

(3) **The Rate of Gasification.**—In the above-cited experiments by Bone and Wheeler the rate of gasification was as high as 35 lbs./hour/ft.<sup>2</sup> grate area, and a similar performance is claimed in the "Alma" producer—modified Mond type—designed by them.

The rates attained in usual working are, however, more of the order of 15 lbs./hour/ft.<sup>2</sup> grate area.

The nature of the reactions taking place in the generator is well illustrated by the experiments carried out by Wendt on a technical semi-water gas producer with a fuel bed of 7½ ft. depth.

TABLE 36.

WENDT'S EXPERIMENTS ON SEMI-WATER GAS PRODUCTION.

Height above tuyère. Inches.	Temperature °C.	H <sub>2</sub>	CO	CO <sub>2</sub>	CH <sub>4</sub>	N <sub>2</sub>	O <sub>2</sub>
0	—	—	—	11·4	—	79·1	9·5
10	1110	10·5	22·0	9·3	0·4	57·5	—
20	—	13·7	28·0	5·5	0·9	51·9	—
30	925	17·9	32·7	3·0	1·2	45·2	—
40	—	21·8	28·7	5·0	5·0	39·5	—
50	810	20·7	28·3	6·0	4·8	40·2	—
60	—	19·0	28·0	5·3	4·1	43·6	—
Outlet	440	14·6	26·8	5·5	3·4	49·7	—

Tar was present at and above the zone 40 in. above the tuyère. Depth of fuel, 7' 5".

It will be noted that the temperatures are considerably lower than those in the corresponding tests in the same generator in the absence of steam (p. 314). The carbon



monoxide concentration rises to a maximum and the carbon dioxide concentration falls to a minimum at 30 in. above the tuyère, the less favourable water gas equilibrium at the lower temperature in the upper regions causing conversion of monoxide into dioxide. Methane and hydrogen are given off in the upper layer from the bituminous fuel, much of the sensible heat of the gases being absorbed in the process of distillation.

### Semi-Water Gas Plants

**General.**—The plants for the production of semi-water gas may be described under the two general headings of pressure plants and suction plants according as the pressure in the generator is greater or less than atmospheric. Pressure plants are used for all furnace gas production and for most large power installations (over about 500 H.P.), while suction plants are convenient for relatively small power plants.

**Pressure Plants.**—A pressure gas plant consists essentially of a vertical cylindrical shaft lined with firebrick, having a fuel bed usually about 3–7 ft. in depth, and suitable arrangements for charging from the top, *e.g.* by the use of a double cone hopper, without loss of gas. A definite mixture of air and steam is blown upwards through the fuel bed, either by a steam injector or by a fan or blower, the steam in the latter case being introduced either directly or by passage of the air through or over water heated to the appropriate temperature. It is important to have a thorough knowledge and control of the steam/air ratio at all times.

Uniformity of the blast throughout the fuel bed is all-important. The method of effecting such distribution varies from the practice of using as tuyère a perforated hut-shaped box as in the Duff producer, or some other distributing device at the bottom of the generator, to the method most usually adopted of enclosing the grate in an airtight casing to which the blast is supplied. The grate may consist either of horizontal fire-bars or of circumferentially disposed bars inclined at about 45° C. to the vertical, *e.g.* as in the Mond

and Alma producers. The area of the grate should be approximately equal to that of the generator section, otherwise excessive local heating and clinkering are liable to occur.

A point of great importance is the provision of suitable means for effecting the removal of the ashes. In most types, *e.g.* the Mond producer, the casing enclosing the grate is open below and is sealed by water, this procedure allowing of the removal of the ashes through the water without interruption of the working. Considerable trouble is caused by the production of clinker, which is difficult to remove and offers resistance to the passage of the blast, and by the adherence of such clinker to the lining in the zone of highest temperature, *i.e.* just above the grate; consequently, in some plants, *e.g.* the Kerpely, the walls of the producer corresponding to the lower third of the fuel bed are water-jacketed. This procedure has also the effect of furthering ammonia recovery (*vide infra*). In this generator the ashes are automatically removed by means of a special revolving grate. This consists of a perforated eccentrically constructed conical furnace bottom mounted in a circular trough which revolves once in 2-4 hours, a water-sealed joint being made with the furnace casing. The eccentric construction has the effect of breaking up and ejecting clinker. Air may be admitted either uniformly over the whole of the conical surface or preferentially at the centre or the periphery. In order to protect the fire-bars of producers from the high temperatures attending the first action of the air on the fuel and to minimize loss of heat, a fairly deep layer of ashes rests on the actual grate, but for small producers this procedure is not always followed. Arrangements are provided in some types of producer for automatically clearing the fire-bars. According to recent tests by Bunte and Terres (*J. Gasbeleucht.*, 61, (1918), 433, 445) with Kerpely-Marischka producers, the thermal efficiency was 81.6 %, while the loss by radiation was equivalent to about 2 % of the total heat, all the steam being generated by the water-jacket boiler.

A high rate of gasification is important and depends on adequate grate area and on the avoidance of choking and channelling in the fuel bed. Such troubles may be caused by the fuel being too small or having a tendency to cake. In the Kerpely producer referred to above, four special J-shaped stirrers are arranged in the upper part of the fuel bed and slowly revolve about their axes and also as a whole round the furnace. This type of producer, which is used chiefly on the Continent, is well suited for the gasification of very low grade fuels, in treating which blast pressures up to 30 in. of water are employed. It was shown in Bone and Wheeler's experiments (p. 329 *et seq.*) that a shallow fuel bed, of  $3\frac{1}{2}$  ft. depth, gave a carbon dioxide content approximately equal to that obtained with the 7-ft. bed, and in addition gave a higher rate of gasification owing to the decreased resistance of passage. Further, less trouble with clinker and adherence of same to the producer are experienced. Many producers are operated with beds of about this depth, while in others depths up to about 7 ft. are used.

As regards the influence of the size of the fuel on the reaction velocity, the active surface exposed will be roughly inversely proportional to the size of the lumps of fuel. Dryness of the steam is important, and in many producers a pre-heating is effected, either by definite heat-interchange with the hot gases leaving the producer, or by passage through the annular space surrounding the lower part of the producer. The blast pressure in pressure producers is usually about 3-6 in. of water, but may be as high as 20 in. or even higher. Some producers have a bell projecting into the upper part of the interior in order to minimize tar production by compelling the products of distillation of the upper layers of fuel to pass through the highly heated zone; the efficacy is, however, doubtful.

Useful data relating to the operation of various makes of producers are given by Mills (*Trans. Inst. Mining Engineers*, (1915), 723).

**Ammonia Recovery and Cleaning of Semi-Water Gas.**—The extent to which the purification of semi-water gas

from suspended matter is carried, is necessarily dependent on the purpose to which the gas is to be put. If to be used directly in furnaces, the 5 % or so of the total carbon going to tar is with advantage left in the gases both on account of its calorific value and to avoid loss of the sensible heat of the gases, the temperature of which is usually about 500–600° C. on leaving the generator. When such purification of the gas is necessary, principally in the production of gas for power purposes, the removal of the tar, except in the case of relatively small suction plants, is usually performed in conjunction with ammonia recovery and it will be advantageous to consider the two operations together. In the first place, when ammonia recovery is to be effected it is necessary to keep down the temperature in the producer (cf. Table 24, p. 216, relating to the concentrations of ammonia existing in equilibrium with nitrogen and hydrogen at high temperatures), and this is usually accomplished (1) by the use of a large proportion of steam in the blast, (2) by cooling the walls of the generator.

The influence of the steam/air ratio is well shown by the experiments of Bone and Wheeler (cf. Table 35), in which the ammonia recovered is seen to rise from 39 to 72 lbs. ammonium sulphate per ton coal according as the saturation temperature is changed from 60° C. to 80° C., equivalent to a variation of the weight of steam per lb. fuel from 0.45 to 1.55 lbs. This advantage is, of course, gained at the expense of a considerable increase in the percentage of carbon dioxide and of a greater loss of heat in the gases.

In the Moore producer for ammonia recovery (cf. *Engineering*, (1915), 326), by water-jacketing the walls of the producer of which the upper part is air cooled, the water-jacket acting as a steam boiler, it is claimed that effective ammonia recovery can be secured with the use of only about 1 lb. steam/lb. fuel, half of which steam is generated by the annular boiler, as compared with 1½ to 2 lbs. in usual Mond practice. The gas produced has the percentage composition—

Hydrogen .. .. .	26.0
Carbon monoxide .. ..	18.4
Carbon dioxide .. ..	11.6
Methane .. .. .	2.2
Nitrogen .. .. .	40.0
Water vapour .. .. .	1.8
	<hr/>
	100.0

and leaves the generator at a temperature of about 200° C.

**Mond Process.**—The first attempt at gasification of coal with ammonia recovery and the production of a cheap fuel gas was due to Mond, who erected an experimental plant in the Midlands in 1879; the success of this experiment led to the construction of the present large plant. In the Mond process, the air-steam blast is led into an annular casing surrounding the lower part of the producer and serving to some extent as a pre-heater. The grate has inclined fire-bars and is water-sealed. In view of the high steam content—about 2 lbs./lb. coal, equivalent to saturation at about 85° C.—only  $\frac{1}{3}$  of which is decomposed, it is necessary to arrange for the efficient recuperation of the sensible heat carried away from the producer thereby. The gases, together with the excess steam, leave the generator at a temperature in the region of 500–600° C. and pass first to a heat-interchanger, being cooled to 300–400° C. by the counter-current flow of the air-steam blast entering the generator. Further reduction is effected in a water washer fitted with agitators where also the tar is mostly removed, and ammonia is abstracted by passage up a tower down which a solution containing about 36–38 % ammonium sulphate and some 2.5 % of free sulphuric acid is flowing. The gases emerge at a temperature of about 80° C., and are cooled in a further tower with water which is subsequently utilized for the saturation of the blast at about 75° C. in a third tower. In the recent types of plant built by the Power Gas Corporation, the towers are sometimes replaced by horizontal chambers. By means of a further quantity of steam the saturation is raised to 85° C. and the wet blast enters the generator after traversing the

heat-interchanger referred to above, whereby its temperature is raised to about 250° C.

With bituminous coal containing 1.2–1.6 % nitrogen a recovery of about 80–90 lbs. ammonium sulphate/ton coal can be realized on the Mond system with a yield of gas equivalent to about 160,000 ft.<sup>3</sup> at 15° C. per ton coal (14.0 lbs. coal/1000 ft.<sup>3</sup> at 15° C.) of calorific value about 87 gross, 78 net C.H.U./ft.<sup>3</sup>.

A representative analysis of semi-water gas with ammonia recovery is given in Table 29. It will be noted that the hydrogen and carbon dioxide are high and the carbon monoxide low. The large plant operating at Dudley Port on the Mond system produces gas of net calorific power about 75 C.H.U./ft.<sup>3</sup> at 15° C., which is distributed over an area of about 120 square miles, the cost (pre-war) being about 1½d./1000 ft.<sup>3</sup>. The chief drawbacks of the Mond process are the high percentage of inert matter—nitrogen, carbon dioxide—present in the gas, and the large capital outlay which renders a plant of turnover less than about 150–200 tons coal/week unprofitable. The latter objection, it is claimed, has been met by plants of later date, *e.g.* the Crossley plant, which claims to work profitably with a weekly fuel consumption of about 100 tons, the Lymn plant (*Engineering*, (1915), 624), etc. In the Crossley plant the general procedure is similar to that followed in the Mond process, the main difference consisting in the replacement of the towers by a series of chambers fitted with revolving paddles. In these chambers cooling and ammonia absorption are effected, the hot liquor—at about 80° C.—being circulated to saturate the incoming air—at about 60° C.—and returned at about 40° C., slightly acidified with sulphuric acid, to the absorbing chamber, a portion being periodically removed for evaporation. It is possible to gasify successfully even such fuels as lignite, peat, etc., containing 60 % moisture, by the Mond process.

### Use of Semi-Water Gas for Furnace Operations

The most important application of semi-water gas for furnace work is in the Siemens open-hearth furnace for steel

melting. The hot gases leaving the generator at 500–600° C. and containing a considerable amount of tar, are led to the regenerator which consists of chambers filled with chequer-work. The chambers are traversed alternately by the products of combustion in the furnace and by the incoming gas and air, the two latter entering through separate chambers, of course. The temperature in the regenerator is in the neighbourhood of 1100–1200° C. and the steel is heated to about 1600° C.

According to Hadfield (*Soc. Brit. Gas Industries*, Presidential Address, April 18th, 1918), the volume of air used in the practical operation of such a furnace is found to be from  $1\frac{1}{2}$ –2 times that demanded by theory; the volume of semi-water gas required for the melting of 1 ton of steel in the open-hearth furnace is stated to be about 48,500 ft.<sup>3</sup> or 21.6 ft.<sup>3</sup>/lb., equivalent to a thermal efficiency of the order of 17%, taking the net calorific value of semi-water gas as 85 C.H.U./ft.<sup>3</sup>

Stress has already been laid on the importance of avoiding excess hydrogen and of maintaining a high carbon monoxide content; 12–14% hydrogen is considered the maximum which is desirable (Bone), both on account of the radiation from the flame and the danger of back-firing.

### The Production of Power by the Combustion of Semi-Water Gas in Gas Engines

Some reference has already been made to the advantages of internal combustion engines for the generation of power especially for relatively small units. Since, as we shall see later, the overall net efficiency, *i.e.* inclusive of the steam for the generator and the power for operating the blowers, scrubbers, etc., of a gas producer may be safely taken at 75%, then for 7000 C.H.U./lb. coal, we have 5250 C.H.U. in the gas. Now the efficiency of a modern gas engine is about 27%—referred to B.H.P.—being practically independent of size over say 100 H.P. The useful power production, therefore, will be equivalent to  $5250 \times 0.27$  C.H.U. = 1417 C.H.U., and since 1 B.H.P.H. = 1415 C.H.U., to

1417/1415 B.H.P.H. = 1.00 B.H.P.H./lb. coal; the overall efficiency being  $1417/7000 = 0.202$ . With 100 % efficiency, 1 lb. of coal would produce about  $7000/1415 = 4.95$  B.H.P.H.

Using steam power, on the other hand, with a boiler efficiency of say 75 %, representative of good practice, and an engine efficiency of say 15 %, a value only obtained with large units, we have a final power production equivalent to  $7000 \times 0.75 \times 0.15$  C.H.U./lb. coal = 787 C.H.U. =  $787/1415$  B.H.P.H. = 0.56 B.H.P.H. per lb. coal, or 1 B.H.P.H. for 1.8 lbs. coal, the overall efficiency being  $787/7000 = 0.112$ .

It should be pointed out that the above values apply only to very large units. In the case of gas engines, however, the figures are only slightly lower for plants of say 100 H.P. or even smaller, while the efficiency for a similar steam plant may be of the order of half. On the other hand, the very large modern turbine sets now in vogue for electrical power generation give an almost equivalent efficiency, e.g. the 35,000 H.P. Parsons turbine plant recently installed at the Fisk Street power station, Chicago, uses steam equivalent, if we take a boiler efficiency of 75 %, to about 1 lb. coal per B.H.P.H.; this represents an efficiency of about 27 % in the steam turbine. Another point in favour of steam plant for large power units is the lower maintenance cost.

An interesting possibility of increasing the overall thermal efficiency of the power production lies in the utilization of the sensible heat of the exhaust gases of a gas engine, e.g. by passage through Bone-Court or other boilers and utilizing the steam thus produced in the usual way. With such a procedure, from the 40 % or so of the heat units of the gas which leave in the exhaust ( $= 40 \times 0.75 = 30$  % of the original calorific value of the fuel) taking a boiler efficiency of 0.75 and an engine efficiency of 0.15, we have another  $30 \times 0.75 \times 0.15$  % = 3.4 % to add to the overall thermal efficiency. An alternative scheme is to generate steam by direct combustion of producer gas, produced from very low grade fuel, under the boilers. The foregoing remarks as to efficiency relate also to gas engines working on blast furnace gas (*vide infra*).



**Plants for Power Generation.**—For this purpose we have a choice of pressure plants, either with or without ammonia recovery, and suction plants, and of using as fuel anthracite, coke, bituminous coal, lignite, etc. The respective economics of the alternatives are somewhat complex but it will suffice to give a few generalizations. Suction plants are used up to sizes of the order of 500 H.P. on account of their greater thermal efficiency and are usually operated with anthracite or gas coke for relatively small plants, say 250 H.P., to avoid the troublesome cleansing treatment, with its attendant loss of pressure on the engine suction pipe, necessary with bituminous fuel. When, however, very large plants are required, of 1000–2000 H.P., the importance of ammonia recovery and of the utilization of low grade fuel outweighs the cheapness and convenience of the suction plant.

In all cases, it is important to remove the tar very thoroughly and to cool down the gases practically to atmospheric temperature before admission to the engine. Using anthracite the problem is comparatively simple and scrubbing in towers containing coke moistened with water is often sufficient, though this is sometimes preceded by passage through atmospheric coolers, and, when using coke or inferior anthracite, further treatment in a dry sawdust scrubber may be required. With bituminous coal it is necessary (1) to take steps to minimize the production of tar in the generator, or (2) to use a centrifugal or static extractor after the scrubbers. Method (1), which is not so much in favour as (2), depends on the passage of the gases arising from the distillation of the fuel in the upper layers of the generator, through the zone of high temperature, *e.g.* in the Dowson plant a supply of secondary air is taken in at the top of the producer and the gases are withdrawn at about the centre of the fuel bed; in the Duff-Whitfield producer the tarry vapours from the upper part of the producer are drawn away by steam injectors and forced upwards through the lower, high temperature zone of the fuel bed, the gases leaving at about the centre of the bed. The “cracking” of tar proceeds very slowly, however,

and for this reason method (2) is generally considered preferable. (2) Static tar fog separators usually depend on the principle of bubbling the gas in fairly fine streams through water, as in the Livesey apparatus, the gas passing through narrow orifices or slits; or in subjecting to abrupt changes of direction by suitable baffles as, *e.g.*, in the Pelouze and Audouin separator. Surfaces covered with a film of tar are much more efficacious in the removal of suspended tar than when moistened with water. In the Smith Gas Power Corporation's separator, the gas is filtered through a glass-wool mat, a pressure drop of from 2-4 lbs./in.<sup>2</sup> being necessary. The dynamic types usually rely on centrifugal force. Thus in the Crossley centrifugal fan extractor, the gas, together with water passes over the periphery from one side of a rapidly rotating disc fitted with vanes, to the axis on the other side. Mention may also be made of the method of electrostatic separation which has been found to effect a satisfactory removal of tar (*cf.* White, Hacker and Steere, *J. Gas Lighting*, **119**, (1912), 825; White, Rowley and Wirth, *J. Soc. Chem. Ind.*, (1914), 1000; Steere, *Ib.*, (1914), 1145; (1915), 415). In *Gas J.* (1918), August 13th, it is stated that coal gas can be treated with a power expenditure of 0.0008 K.W.H./1000 ft.<sup>3</sup>. In all scrubbing appliances for suction plants it is important to make the loss of head as small as possible as pointed out above, hence sawdust filters, etc., are preferably made of disc form rather than long and narrow; sometimes a booster fan is inserted before the engine.

**Suction Plants.**—The principle of drawing the gas through the generator by the suction of the engine (originally suggested by Bénier (1896), the technical development of the modern gas engine operating at high compression on gases of low calorific value being mainly due to the pioneering work of Dowson) has led to the evolution of a very compact and serviceable type of power plant which now plays an important rôle in power generation and is destined to have even greater importance in the future.

Suction plants have an advantage in the reduction of risk of carbon monoxide poisoning owing to the prevailing

negative pressure. Gas from pressure producers has usually a slightly higher calorific value than that from suction plants, (10-20 %); further, the pressure drop with the latter, of the order of 6 in. of water, renders the power development with a given engine somewhat smaller. In the smaller suction plants the steam is often generated in an annular boiler disposed as a jacket to the generator, loss of heat by radiation being thus minimized; in other types the sensible heat of the gases is utilized in a multitubular vaporizer; flash vaporizers are also employed. The result is to make the overall thermal efficiency somewhat greater than for pressure producers with independent boilers. The sensible heat of the exhaust gases may be employed for steam raising as *e.g.* in the Smith (Ohio) plant.

A point in connection with suction plants requiring some attention is the lag in the response of the generator to a sudden variation of load on the engine; if the load has been light for some time the temperature in the fuel bed will fall and, on a sudden rise in the gas requirements, only a poor gas will be available for a period. This difficulty is minimized by the use of a gas-holder and by allowing the gas to go to waste during such "heating up" periods, or alternatively, by making some gas to waste during the light load period. In some cases automatic steam regulation operated by the gas-holder is provided.

On starting up a suction generator the procedure is to "blow up" the producer with an auxiliary fan, the gases passing to the flue until of sufficiently good quality, as judged from the flame at a test cock. The depth of fuel bed varies from 2-3 ft. according to the size of the plant. According to Burt, the volume of the generator varies from 0.12 to 0.18 ft.<sup>3</sup>/B.H.P. as the capacity increases from 20-100 B.H.P.; the grate area is usually some  $\frac{3}{4}$  that of the cross-section. Owing to the necessity for continuous working over long periods, ample capacity must be allowed for the accumulation of the large lumps of clinker; charging of fuel is usually performed only at intervals of say 6-12 hours, adequate fuel capacity being provided. The arrangement

of a layer of ashes above the fire-bars is usual in suction producers. The rate of gasification is of the order of 15–30 lbs./ft.<sup>2</sup> depending on the fuel burnt. Special types of generator are used for small, waste fuels, etc., as, *e.g.* the Ruston plants for the gasification of sawdust, straw and the like. Even untreated seaweed may be used. Owing to the method of generating the steam in suction plants the saturation temperature is liable to vary considerably both from time to time and from one plant to another; less variation is experienced with flash vaporizers with automatic regulation of the water feed. The net thermal efficiency, allowing for the power of the suction and including the generation of the steam, is usually 75 % to 80 %. Fuel consumption varies from about 12 lbs./1000 ft.<sup>3</sup> of gas at 15° C. with anthracite to about 16 lbs. with bituminous coal.

#### Use of Suction Gas in Internal Combustion Engines.

—Reference to Table 29 will indicate that although considerable differences exist between the calorific values of the various fuel gases, *e.g.* that of coal gas is some 4 times that of suction gas, there is little difference between those of the theoretical mixtures with the necessary air for combustion except in the case of semi-water gas, air producer gas, and blast furnace gas, which have slightly lower values. Further, in practically all cases gaseous fuels are used with a sufficient excess of air (a relatively small excess being required for semi-water gas, blast furnace gas, etc.), to reduce the calorific value of the mixture to about 25–30 C.H.U./ft.<sup>3</sup>, it being specially necessary to keep down the calorific value in very large engines.

The permissible degrees of compression without causing pre-ignition are given by Lucke as:—

Gas.	Coal gas.	Semi-water gas.	Blast furnace gas.
Compression (lbs./in. <sup>2</sup> excess pressure)	80	135	155

Trouble experienced with pre-ignition is usually attributed to the presence of excess hydrogen, but considerable doubt appears to exist on the point; apparently mixtures as rich

as 40 % hydrogen can be worked successfully if the compression be not too great (cf. discussion on paper by Bone and Wheeler, p. 329). There is some evidence to suggest that pre-ignition may be caused by the minor constituents of semi-water gas, *e.g.* to traces of carbon disulphide, acetylene, etc.

An interesting discussion of the above mentioned points relating to gas engines will be found in a paper by Tookey (*J. Soc. Chem. Ind.*, (1917), 309). As regards the volume of gas required for the production of 1 B.H.P.H. = 1415 C.H.U., taking the efficiency of the engine at 27 %, the heat units required in the gas

$$= \frac{1415}{0.27} \text{ C.H.U.} = 5250 \text{ C.H.U.}$$

and, taking the net calorific value of suction gas as 70 C.H.U./ft.<sup>3</sup> at 15° C., we see that the requirements are

$$\frac{5250}{70} \text{ ft.}^3 = 75 \text{ ft.}^3 \text{ at } 15^\circ \text{ C.}$$

This applies to a fairly large plant.

According to Brame, coal gas becomes less economical than suction gas when the plant exceeds about 50 H.P.

We have seen above that the production of B.H.P.H. should require the gasification of about 1 lb. of coal, and this amount is closely approached when anthracite is used even in small plants and is improved upon in many.

### Coal Gas as a Fuel

It is not proposed to enter into a description of the manufacture of coal gas, an average composition of which may be found in Table 29. The composition varies to some extent with the temperature of carbonization and with the size of the retort and is somewhat different with the modern continuous system. The effect of high carbonization temperatures is to raise the percentage of hydrogen and to lower that of methane. The coal required per 1000 ft.<sup>3</sup> of gas at 15° C. is usually of the order of 17–20 lbs. The former legal standard was one of illuminating power, namely 16 candle power per ft.<sup>3</sup>, but with the advent of the incandescent mantle together with the increasing use of coal gas for power

and heating purposes this standard became of secondary importance and in some districts has been partly replaced by one of calorific value, namely 276 C.H.U./ft.<sup>3</sup>.

It should be remembered that nearly all town gas contains a considerable proportion of carburetted water gas or even of blue water gas; the calorific value of carburetted water gas is, however, not greatly different from that of coal gas.

The sulphur content of coal gas is important in connection with its domestic and industrial uses, *e.g.* in metal melting, annealing, etc., at least in such cases as the metal is exposed to the products of combustion. The initial high content (according to Meade the H<sub>2</sub>S present in crude coal gas is of the order of 500–800 grains/100 ft.<sup>3</sup> = 0·8–1·3 % by volume, in addition to some 35–50 grains/100 ft.<sup>3</sup> of other sulphur compounds) is reduced by methods described elsewhere to a value of the order of 35–50 grains/100 ft.<sup>3</sup>, the residue being mostly carbon disulphide.

**General.—Applications of Coal Gas.**—For small plants, coal gas has many advantages over the cheaper producer gas on account of the absence of any overhead or standby costs in the way of generators, gas-holders, and fuel storage, and in uniformity as regards quality, pressure, etc.

**Furnace Operations.**—Of late years, and especially during the war, gas firing has come into extensive use for metal melting, annealing, and reheating operations. Much useful information on the subject of gas firing of crucibles for the melting of non-ferrous alloys may be obtained from the Annual Reports of the Royal Mint, the results of the working being summarized by Hocking in *Trans. Inst. Metals*, (1917), ii., 149. The following table, compiled from Hocking's paper, indicates the general result of changing the melting system from one using coke to a gasfired system:—

	Fuel used per lb. metal.	Cost of fuel per ton metal (coke, 38·7s. per ton) (gas, 20·2d. per 1000 ft. <sup>3</sup> ).	Cost in crucibles per ton metal.
Coke melting (1905–1909)	0·55 lbs.	21·3 shillings	39·8 shillings
Gas melting (1911–1916)	5·45 ft. <sup>3</sup> .	20·58 shillings	26·8 shillings

If the net calorific value of the coke be taken as 8000 C.H.U./lb. and that of the gas be taken as 280 C.H.U./ft.<sup>3</sup>, the heat units expended per lb. metal are (1) coke, 4400 C.H.U.; (2) gas, 1526 C.H.U.

A reduction in wages from 15·7 to 10·8 shillings per ton metal was also recorded for the years 1909 and 1913 respectively with coke and gas firing. The output per furnace was increased to from 190 % to 260 % of that realized with coke according to the alloy melted. The gain in speed is, of course, most pronounced with the first heat.

Somewhat similar conclusions are arrived at by Brook, using a Brayshaw furnace (*Trans. Inst. Metals*, (1917), ii., 171). According to Forster (*J. Soc. Chem. Ind.*, (1917), 1264), the gas consumption varies from 2·4 ft.<sup>3</sup>/lb., equivalent to some 21 % efficiency, in melting 60/40 brass ingots to 8·5 ft.<sup>3</sup>/lb. (efficiency some 7-8 %), in melting cupro-nickel, using the ordinary pit type of furnace. Amongst advantages may be mentioned the ease of recovery of spillings by avoiding the necessity of grinding and washing the ashes, as in the case of the coke-fired furnace, this being important in the melting of brass, nickel silver, cupro-nickel, etc., as well as with precious metals; further, the metal from an accidental breakage of the crucible is easily recovered. As regards crucibles, the economy indicated above can only be secured by the use of (graphite) crucibles of special composition; with the ordinary variety, as the author has experienced in the melting of nickel silver, etc., the life is apt to be shortened by flaking, owing to local oxidation and to sudden heating which do not occur with a coke furnace.\*

The importance of the crucible costs, which a reference

\* It should be remembered, as pointed out by Thornton and Hartley, *Trans. Inst. Metals*, (1917), ii., 306, that the oxidation of the graphite crucible does not depend simply on the presence of less oxygen than that corresponding to the stoichiometric requirements for combustion; the attack on the carbon will depend on the ratio of the carbon dioxide to carbon monoxide at any particular temperature, this ratio in turn being conditioned by the completeness of combustion and by the water gas equilibrium. Even when a considerable excess of gas is used the ratio CO<sub>2</sub>/CO will be fairly high, and a consideration of the CO/CO<sub>2</sub>/C equilibrium at the partial pressures in question (compare *e.g.* p. 303) will suffice to show that in the case of carbon, oxidation will always tend to occur,

to the table will show to be greater than that of the fuel, is not always realized in the consideration of non-ferrous melting.

Amongst other advantages of gas firing may be mentioned (cf. Greenwood and Hutton, *Trans. Inst. Metals*, (1917), i., 237)—(1) the greater ease of regulating the heating and of maintenance of a slightly reducing atmosphere; (2) decreased contamination of the metal by sulphur; and (3) greater ductility of the alloy, demonstrating itself both by the ordinary mechanical tests, e.g. greater elongation and greater endurance under torsion, and also in the production of "difficult spinnings," a matter of great practical importance. There are, however, some disadvantages, such as the noise, increased zinc losses due to the rapid movements of the gases, etc.

The above remarks apply particularly to the usual practice of intermittent working in non-ferrous melting; for continuous working on a fairly large scale, regenerative producer gas furnaces are more economical. Thus, Teisen (*Trans. Inst. Metals*, (1917), ii., 257) reports for a Hermansen counter-current recuperative furnace, a coke consumption of 0.18 lb./lb. brass melted. In the design of melting furnaces it is important to keep down the combustion space round the crucible, the resulting high gas velocity producing better heat-interchange, cf. p. 45; the shape of the inlet nozzle is also important.

Thus far only melting furnaces have been considered. Turning to the more general aspects of the question, gas furnaces may be divided into three general classes: (1) those operating with gas at a pressure of 2 to 3 in. of water and drawing in air like the ordinary Bunsen burner; (2) those operating with gas at a pressure of 2 to 3 in. of water and air at 1 to 3 lbs./in.<sup>2</sup>; and (3) those operating with gas at a comparatively high pressure, e.g. 12 lbs./in.<sup>2</sup> on the Bunsen principle. System (3), which has been applied on an extensive scale in Birmingham, gas being distributed at a pressure of 12 lbs./in.<sup>2</sup> (cf. Walter, *Trans. Inst. Metals*, (1917), ii., 185), is more or less equivalent to (2). It has the advantage of dispensing with the use



of a blower, the gas consumption is greater than with (2), but the lining suffers less. Various intermediate procedures have been adopted, *e.g.* in the internally-fired reheating furnaces built by the Richmond Gas Stove Company; these are fed with air at a pressure of a few inches of water from a fan, the air not being mixed with the gas before the point of combustion. A luminous flame results. The incoming air passes through fireclay tubes in the furnace bed, in counter-current to the exit gases, and a high efficiency is attained. Thus, 100 to 300 ft.<sup>3</sup> of coal gas are required per cwt. metal annealed, according to its thickness. Much more may be expected in the future from development of the principle of utilizing the heat of the products of combustion for the preheating of the metal and the air. Efforts in this direction have given thermal efficiencies of the order of 20 %. Preheating of the gas tends to cause carbon deposits by cracking. One of the best known furnaces of type (2) is the Brayshaw furnace. In many annealing operations, the maintenance of a neutral or reducing atmosphere is of great importance in avoiding surface oxidation, decarburization, etc.; gas-fired furnaces are eminently suited for such purposes. Further, using gas, uniformity of temperature throughout the furnace is readily secured.

According to Hadfield (*loc. cit.*, p. 341), the volume of coal gas required for the heating of steel in bulk to 900° C. is 1·23 ft.<sup>3</sup>/lb., equivalent to a thermal efficiency of 32 %. To give an idea of the impetus given by the war to the use of coal gas, it may be mentioned that the consumption during the year 1917 at the works of Messrs. Hadfield, Ltd., was 360 million ft.<sup>3</sup>, while in some towns the consumption has been more than doubled.

Coal gas is used extensively in the heat treatment, forging, etc., of tools, including those of high speed steel, which demand a temperature of about 1300° C.; also for the annealing of glass and wire; in the textile industries; in heating shell-varnishing stoves, and for other purposes too numerous to mention.

**Power Production.**—Reference has been made to the

relative advantages of coal gas and semi-water gas for power production. Since the modern gas engine has a net efficiency of some 27 % on full load, the volume required per B.H.P.H. of coal gas with a net calorific value of, say, 280 C.H.U. (504 B.T.U.) per ft.<sup>3</sup> at 15° C.

$$\begin{aligned} &= \frac{1415}{280 \times 0.27} \text{ ft.}^3 \text{ at } 15^\circ \text{ C.} \\ &= 18.7 \text{ ft.}^3 \text{ at } 15^\circ \text{ C.} \end{aligned}$$

equivalent to 5250 C.H.U.

**Other Applications of Coal Gas.**—It is hardly necessary to dwell here on the domestic uses of coal gas. One may, however, mention that the modern gas fire has an over-all efficiency up to about 75 %, some 35 to 50 % being directly radiated into the room.

During the war, owing to the scarcity of petrol, coal gas has been used for motor traction, in flexible rubber containers and also compressed to some 50 atmospheres in steel cylinders or to about 17 atmospheres in the equivalent of a large pneumatic tyre. It is found that in practice 1000 ft.<sup>3</sup> are equivalent to 3 to 4 gallons of petrol.

Coal gas, preferably after being bubbled through ammonium hydroxide, is used for case hardening (cf. *J. Gas Lighting*, **132**, (1915), 312 ; **134**, (1916), 691).

### Coke-oven Gas

In the production of coke for metallurgical purposes, the early "beehive" process which is, one regrets to say, still in use in this country, depends on the partial combustion of the coal (coking) with no recovery of the ammonia, tar products, etc. In the modern type of coke oven, carbonization is effected in very large closed retorts, and the gas evolved—after treatment for by-product recovery—burnt in part to heat the retorts, reasonable efficiency being secured by the use of regenerators or by passing the hot products of combustion through boilers. Some 50 % of the total gas produced is required for the heating of the retorts ; the rest is available. The gas has a composition similar to that of coal gas, but may

contain more nitrogen owing to ingress of air. The weight of coal required for 1000 ft.<sup>3</sup>, if no gas were used for heating; the calorific value of the gas; and the volume required for the production of one B.H.P.H., are similar to the corresponding values for coal gas.

When one considers that some 20 million tons of metallurgical coke are produced annually in this country, the possible recovery of gas is seen to be of the order of 13 million ft.<sup>3</sup> per hour, equivalent to about 600,000 H.P. Utilization for power purposes is already in progress on a large scale on the North-east coast, while in some cases, *e.g.* at Leeds, Middlesbrough and Sheffield, the gas is piped for municipal supply. In such cases the poorer first and last portions of the gas are often collected separately and used for the heating.

Coke-oven gas is often used in admixture with blast furnace gas for heating steel furnaces. When used in this way, passage through the regenerators reduces the calorific value per unit volume by some 30 % (Simmertsbach, *Stahl u. Eisen*, **33**, (1913), 239, 273), and there are advantages in heating the air alone. By burning under steam boilers an efficiency of 60 to 70 % can be obtained with an evaporation of about 5 lbs./ft.<sup>2</sup>/hr. (*cf.* Kershaw, *Engineer*, **124**, (1917), 28).

### Blast-furnace Gas

In the smelting of iron ore the necessary temperature is obtained by the combustion of (excess) carbon by air, resulting in the production of very large volumes of gas similar in composition to air producer gas except that more carbon dioxide is present (*cf.* Table 29). Originally allowed to burn at the throat of the furnace, the gas was used later (1837) for the pre-heating of the blast and also for steam raising, but a surplus still remained, increasing as the hot-blast stoves were made more efficient.

For each ton of pig iron produced, about 150,000 ft.<sup>3</sup> of gas are obtained (according to Hubert), some 60 % being required for the hot-blast stoves and for generating power

for the blast, etc. Thus, for each ton of iron we have some 60,000 ft.<sup>3</sup> of gas of net calorific value about 57 C.H.U./ft.<sup>3</sup>. Taking as before an efficiency of 0.27 in the gas engine, the power production per ton of iron

$$= \frac{60,000 \times 57 \times 0.27}{1415} \text{ B.H.P.H.}$$

$$= 652 \text{ B.H.P.H.}$$

In consideration of the enormous quantities of coke used for blast furnaces—upwards of 10 million tons/annum in this country—the possible power development is obvious. Some power stations on these lines are in operation on the North-east coast. It was predicted by Hutchinson of the Skinningrove Iron Company, that the potential energy of the blast furnace gas would suffice to produce all the power required for the production of finished steel rails from the ore. The high compression of about 155 lbs./in.<sup>2</sup> is used without risk of pre-ignition.

It is essential to remove very thoroughly the large amount of dust in the gases—about 5 grams/m.<sup>3</sup>—the removal being effected either dry by bag filters after cooling the gas, since it leaves the furnace at about 250° C., or wet by a Theissen fan (Reinhardt, *Trans. Iron and Steel Inst.*, (1906), iii., 47), the maximum permissible residue being of the order of 0.01 gram/m.<sup>3</sup>, or by a combination of the two methods (cf. also electrostatic dust removal (p. 28). With reference to the recovery of potash from the blast furnace gases, see Chance, *J. Soc. Chem. Ind.*, (1918), 222T; Berry and M'Arthur, *Ib.*, 1T.

### Natural Gas

Natural gas is evolved from petroleum wells in prodigious quantities in the United States and Canada. In smaller amounts it has been found also in Hungary, near Hamburg, and even in England (Heathfield in Sussex). A representative composition is given in Table 29, but there is considerable variation from well to well and also with the amount drawn from a particular source. Thus, hydrogen may be

present to the extent of about 20 % while 1 % of carbon monoxide may be found in some samples. Up to about 1 % of helium may be present (cf. pp. 131-3).

The gas is tapped off at pressures up to 40 atmospheres, and is sometimes measured for distribution purposes at this pressure; in this connection the very considerable deviation from perfection of the gas at high pressure is of importance (cf. Burrell and Robertson, U.S. Bureau of Mines, Tech. Paper No. 131).

In the United States and Canada the gas is distributed over very large areas for heating and lighting, some 900,000 million ft.<sup>3</sup> being consumed in 1917. In connection with a recent cyanamide plant in Hungary some 2500 million ft.<sup>3</sup>/annum of natural gas are being utilized for power purposes. If compressed for distribution in cylinders, some of the higher boiling petroleum constituents present are liquefied out and may be separated, the calorific value of the gaseous fraction possibly being lowered by some 20 % (cf. Dykema, U.S. Bureau of Mines, Bull. 151). Natural gas gives a flame of high calorific intensity.

There would appear to be a promising field for research in the utilization of natural gas for the production of formaldehyde—by catalytic oxidation (cf. D.R.P. 214,165)—and of other organic compounds. In D.R.P. 281,084/13 Herman proposes to produce nitric acid by the combustion of methane with oxygen-enriched air under pressure or by surface combustion.

An excellent discussion of the properties and possible applications of methane is given by Malisoff and Egloff, *J. Phys. Chem.*, **22**, (1918), 529.

**Surface Combustion.**—The principle of surface combustion, *i.e.* the flameless combination of two gases on the incandescent surface of a solid, was first suggested by the experiments of Davy in 1817, and has recently been elaborated by Bone as a result of his researches on the catalytic combination of hydrogen and oxygen (*Phil. Trans.*, A **206**, (1906), 1), and developed on a technical basis in conjunction with McCourt.

Perhaps the simplest form is that in which a mixture of gas and air in the correct proportions or with slight excess of air, is forced at considerable velocity through a refractory diaphragm, combustion occurring on the other side which becomes highly incandescent; combination is confined to  $\frac{1}{8}$ " or  $\frac{1}{4}$ " below the surface. It is necessary, of course, that the diaphragm be sufficiently refractory to avoid risk of fusion.

The advantages of such an appliance for heating purposes are: (1) the high proportion of radiant energy, the radiation from a solid surface being proportional to the fourth power of the absolute temperature; (2) the fact that combustion is effected without the use of more than a slight excess of air; and (3) that high temperatures may be readily obtained without the aid of cumbersome regenerators. When applied to the heating of a crucible or a muffle, a granular refractory material such as carborundum or fused magnesia is packed around and the gas mixture introduced with a velocity sufficient to prevent back-firing.

Most attention has been paid, however, to the gas-fired steam boiler, the efficiency of which is notoriously low (usually not exceeding 60 %, according to Bone), owing to the relatively small radiation and the low rate of transmission of heat from gases to surfaces (cf. p. 45). In the Bone-Court system the usual procedure is to pack the tubes of a multitubular boiler—3" to 6" diameter—with a granular refractory; the heating efficiency is confined mainly to the first portions of the tube (about 70 % in the first third) as combination is complete in a short length, the granular material in the remaining portion of the tubes acting merely to improve the turbulence and so increase the coefficient of heat-interchange. It is stated that the gases leave at 130–200° C., a net thermal efficiency of over 90 % being realized. Thus, a boiler with 110 3" tubes (4' long) erected at the works of the Skinningrove Iron Company, Ltd., gave an evaporation of 14 lbs./hr./ft.<sup>2</sup> surface at and from 100° C., burning coke-oven gas, and an efficiency of 93 % or 94 % lagged. In other cases an evaporation of 20 lbs./hr./ft.<sup>2</sup> is claimed.

In the later types wide tubes (about 6") of considerably greater length are used. A specially moulded refractory is used in the tubes, and combustion is not flameless as in the Skinningrove boiler, giving a longer life to the refractory. The air-gas mixture is supplied at a pressure of about 20 in. of water.

The process works best with gases of high calorific intensity, such as coal gas, carburetted water gas, natural gas, etc., but even blast furnace gas may be used by first starting up with coke-oven gas or by using pre-heated air. Large hardening furnaces have been constructed with a thermal efficiency of 32 %, while claims are made for the melting of brass with 1.75 ft.<sup>3</sup>/lb. (cf. p. 349), equivalent to a net thermal efficiency of the order of 29 %. Lead melting is effected by means of a bent submerged tube packed with a granular refractory, with an efficiency of some 69 %.

Diaphragms of the type described have found successful application in the evaporation of sugar solutions.

### Gas Calorimetry

In the control of plant for the production and utilization of gaseous fuels, efficiency and economy are greatly enhanced by the use of calorimetric testing apparatus, especially recording apparatus. The usual type of gas calorimeter, *e.g.* those of Junker and Boys, consists essentially of a central combustion chamber in which the gas flame burns at a burner without touching the walls, the products of combustion being led through or round coils or tubes in counter-current to a regulated stream of cold water, the temperature rise in which is noted by means of suitable thermometers. In the Boys calorimeter the water content is only about  $\frac{1}{6}$  that of the Junker. The thermal efficiency exceeds 99 % under suitable conditions. The condensed water is collected and the necessary correction applied for the calculation of the net calorific value—roughly equivalent to a deduction of 600 calories per c.c. water.

It is not difficult to render such an instrument recording ;

in the Junker instrument this is accomplished by recording the E.M.F. of a differential thermocouple measuring the temperature difference between the inlet and exit water streams respectively, the water and gas rates—or their ratio—being maintained constant by suitable means. The Sarco instrument depends on the difference in the height of two columns of oil interconnected at the bottom, one of the columns being heated by the gas flame and provided with a jacket carrying radiator fins ; net values are indicated.

#### REFERENCES TO SECTION XIII.

Taylor, "Economic Fuel Production in Chemical Industry." This Series. London, 1919.

Brame, "Fuel: Solid, Liquid and Gaseous." 2nd Edition. London, 1917.

Bone, "Coal and its Scientific Uses." London, 1918.

Meade, "Modern Gasworks Practice." London, 1916.

Thorpe's "Dictionary of Applied Chemistry." London, 1912. Articles on Fuel and Water Gas.

Dowson and Larter, "Producer Gas." London, 1906.

Robson, "Power Gas Producers, their Design and Application." London, 1908.

Clerk, "The Gas, Petrol and Oil Engine," New Edit. London, 1909.



## INDEX OF SUBJECTS

- ABRAHAM-MARMIER ozone system, 144  
  water sterilization system, 146-7  
Absolute zero, 7  
Acetates, synthetic production of, 251  
Adiabatic compression of gases, 34-8  
Air producer gas, 313-16  
Air, 58-92; properties, 58  
  Liquid air, useful constants, 69; manufacture, 69-77; properties, 77-8; applications, 78-9; separation of constituents of, 79-92  
Air purification by ozone, 148-9  
Alma producer, 334, 336  
Ammonia equilibrium, 216  
  recovery, 337-40  
  -soda process, 269  
  synthesis. *See* Haber process.  
Argon, 124-8; occurrence, 124; manufacture, 124-7; properties, 127-8; applications, 127-8  
Arc process, 107, 121  
Asphyxiating gases, 291-4  
Atmosphere, composition of, 58-9  
Automatic safety and purity tests, 33-4  
Avogadro's hypothesis, 1
- BALLOONS, 223  
B.A.M.A.G. (Bunte) hydrogen process, 192, 194  
  continuous catalytic hydrogen process, 20, 49, 159-64, 173, 185, 207, 210, 212, 213, 219, 235, 263, 325  
Barium peroxide, dissociation pressure of, 97  
Bedford process for the removal of carbon dioxide, 173, 210  
Bergius hydrogen process, 187-9, 212  
Blast furnace, dry blast for, 50-2  
  gas, 353-4  
  Bone-Court boiler, 356-7  
  Boyle's Law, 2  
  Boys' gas calorimeter, 357  
  Braun nitrogen process, 115  
  Brayshaw furnace, 351  
  Brin process, 96-7, 112  
  British Oxygen Co.'s hydrogen liquefaction apparatus, 154  
  Bucher process, 94, 120-21  
  Burdett electrolytic process, 198, 201
- CALCIUM carbonate, dissociation pressure of, 260  
Calorific intensity, 298  
Calorimetry, gas, 357-8  
Calorific value, 296, 299  
Carbon dioxide, 256-73; occurrence, 256; properties, 43-5, 256-9; dissociation, 257  
  Manufacture, 259-69; pure carbon dioxide, 259-63; utilization of natural sources, 259-60; thermal decomposition of carbonates, 260-61; action of acids on carbonates, 261-2; by-product in fermentation processes, 262; concentration from mixtures with other gases, 209-10, 263-9  
  Applications, 269-72; estimation and testing, 272-3; liquid carbon dioxide, 258, 268; solid carbon dioxide, 258-9, 268-9  
Carbon monoxide, 208, 237-55; properties, 237-41; decomposition of, 237-9; equilibrium with carbon dioxide and carbon, 14-16, 237-9, 303; manufacture, 241-2  
  Applications, 242-54; Mond nickel process, 243-8; production of formates, oxalates and acetates, 248-51; production of gases rich in

- Carbon monoxide—*continued*.  
 methane, 251-2; manufacture of phosgene, 252-4; other applications, 254  
 Estimation, 254-5
- Carbonium Gesellschaft hydrogen process, 192, 212
- Carbonyl chloride, 252-4
- Carbonyls, 243-4
- Carburetted water gas, 322-5
- Cascade method of liquefying gases, 60-61
- Castner-Kellner electrolytic process, 202-3
- Catalysis, heterogeneous, 17-20  
 homogeneous, 17
- Charles' and Gay Lussac's Law, 2
- Charpentier ozone process, 138
- Chemical constant, 15-16
- Churchill electrolytic process, 198, 201
- Cleaning of gases, 27-9  
 semi-water gas, 337-40
- Claude hydrogen system, 165, 170-72  
 liquid air system, 75-7  
 oxygen and nitrogen plants, 87-90
- Claus process, 210, 264
- Claus-Chance sulphur recovery process, 269
- Coal gas as a fuel, 347-52
- Coke-oven gas, 352-3
- Compressed gases, safety precautions, 39-45
- Compressibility of gases, 2-7
- Compression of gases, 34-9
- Conversion factors, 56
- Cottrell precipitator, 28-9
- Critical pressure, 10  
 temperature, 10
- Crossley ammonia recovery plant, 340  
 fan extractor, 344
- Cutting of metals with oxygen, 104-5
- Cyanamide, 85-6, 94, 118-19, 121, 125
- Cyanide process (Nitrogen fixation).  
*See* Bucher process.
- Cylinders, gas, 39, 41-5; Parliamentary Committee on the manufacture of, 39, 44, 45; maximum charges of liquefied gases, 42-5, 268, 280
- DALTON'S Law, 2, 8
- Dellwik-Fleischer water gas plants, 319, 320-21
- Density of gases, 25-6
- Dieffenbach and Moldenhauer hydrogen process, 185-6
- Diffusion, 9-10
- Dowson producer, 343
- Drying of gases, 50-52
- Duff producer, 335
- Duff-Whitfield producer, 343
- EDISON effect, 128
- Effusion, 26
- Electrolysis of water, constants, 195
- Electrolytic hydrogen, 194-203
- Electrostatic separation of impurities from gases, 28
- "Epurite," 99
- Equilibrium, 14
- Exhaled air, composition of, 59
- Explosion, velocity of propagation of, 300-01
- Explosive limits, 40, 202, 297, 300
- FAT hardening. *See* Hydrogenation of oils and fats.
- Formates, synthetic production of, 205, 208, 271-2
- Fuels, classification of solid, 326-7
- Furnaces, use of semi-water gas in, 340-41; use of coal gas in, 348-51
- GAILLARD tower, 28
- Gas analysis, 33-4, 56  
 cylinders. *See* Cylinders, Gas. holders, 52
- Gaseous fuels, fundamental principles relating to use of, 296-301; composition of, 297; fundamental principles of production of, 301-13
- Air producer gas, 313-18
- Blue water gas, 318-22, 325; Lowe system, 319-20; Dellwik - Fleischer system, 320-21; Kramer and Aarts process, 321-2
- Carburetted water gas, 322-5
- Semi-water gas, 325-47; choice of fuel, 326-8; saturation temperature of blast, 328-34; Bone and Wheeler's experiments, 329-32; rate of gasification, 334-5; pressure plants, 335-7; ammonia recovery and cleaning, 337-40 (Mond process, 339-40); use for furnace

Gaseous fuels—*continued.*Semi-water gas—*continued.*

operations, 340-41; production of power from, 341-2; plants for power generation, 343-4; suction plants, 344-7

Coal gas as a fuel, 347-52; coke-oven gas, 352-3; blast-furnace gas, 353-4; natural gas, 354-5; surface combustion, 355-7; gas calorimetry, 357-8

Gases, tables of properties of, 53-6

Gasification in producers, rate of, 334-5

Garuti electrolytic process, 198, 199-200, 202

Gay Lussac's Law, 2

General Electric Co.'s ozone process, 144

Gérard, ozone system, 145

water sterilization system, 147

Griesheim-Elektron field process for hydrogen, 231

hydrogen process, 156, 164-8, 170, 186

HABER process, 94, 119, 121, 213, 215-20

Half-watt lamp, 122, 128

Hampson system of air liquefaction, 69-70

Hänisch and Schröder sulphur dioxide process, 275, 276, 277, 278-9

Harcourt nitrogen process, 113

Hargreaves process, 280

Häusser process, 107-8, 121

Heat-interchange, 45-50, 57

Heat of combustion, 13

Helium, 130-32

Henry's Law, 8, 256

Hermansen furnace, 350

High pressure gas, 350-51

Hildebrandt oxygen and nitrogen plants, 91-2

Hot-wire anemometry, 32-3

Howard-Bridge ozone system, 144

water sterilization system, 147

Humphreys and Glasgow water gas plant, 322-5

Hydrogen, 152-236; Joule-Thomson effect in, 67-8; occurrence, 152; properties, 3, 152-5

Manufacture, stationary plants, 155-207; from water gas, replacement of carbon mon-

Hydrogen—*continued.*Manufacture—*continued.*

oxide by hydrogen, 156-68; from water gas by liquefaction of the carbon monoxide, 168-74; by the action of water or steam on iron or carbon, 174-89 (Iron oxide processes, 175-85; Lane process, 178-82; Messerschmitt process, 182-4; other processes, 184-5; Dieffenbach and Moldenhauer process, 185-6; Bergius process, 187-9); by decomposition of hydrocarbons, 189-94 (Carbonium Gesellschaft process, 192; Rincker and Wolter process, 192-3; Oechelhauser process, 193-4; B.A.M.A.G. process, 194); by electrolysis, 94-5, 194-203; other processes, 203-7; production of a mixture of nitrogen and hydrogen, 207

Purification, 207-13; from carbon monoxide, 208-9; from carbon dioxide, 209-10; from sulphur compounds, 210-11; from other impurities, 211-12

Cost and purity of, 212-13, 234

Applications, 213-21; hydrogenation of oils and fats, 214-15; manufacture of synthetic ammonia, 215-20; other applications, 221

Manufacture in the field, 223-34; portable apparatus, 224-32; Silicon and Silicol processes, 224-7; Hydrogenite process, 227-8; Hydrolith process, 228-9; by action of acids and alkalis on metals, 229-31; other processes, 231-2; semi-portable plant, 232-3; stationary plants, 233; lifting power, 234; effect on fabrics, 234; costs, 234.

Testing of, 235-6

Hydrogenation of oils and fats, 214-15

Hydrogenite process, 98, 227-8

Hydrolith process, 228-9

IGNITION temperature, 299-300

Interferometer, gas, 25

- International Oxygen Co.'s electrolytic process, 198, 200-01
- Internationale Wasserstoff A.G. hydrogen process, 178, 184-5
- Iron carbonyls, 244
- oxides, equilibria in reduction by hydrogen, 175
- oxide processes for hydrogen, 175-85
- JOULE-THOMSON effect, 10-11, 61-8, 154, 170
- Joule's Law, 11
- Junker gas calorimeter, 357
- KERPELY producer, 336, 337
- Kerpely-Marischka producer, 336
- Kitzinger nitrogen process, 115
- Kramer and Aarts water gas plants, 321-2
- Krypton, 132
- LANE hydrogen process, 168, 178-82, 184, 213
- Latent heats of fusion and evaporation, 13
- Level, influence of difference in, 24-5
- Lifting power of hydrogen, 233-4; of helium, 234
- Linde oxygen and nitrogen plants, 81-7
- system of air liquefaction, 73-4; theory of, 61-8, 70-72; effect of pre-cooling in, 72-3
- Linde-Frank-Caro process, 50, 116, 172-4, 204, 210, 212, 215, 219, 222, 233, 242, 251, 263
- Liquefaction of permanent gases, 60-92; theory of Joule-Thomson effect, 61-8
- Liquefied gases, 42-5
- Liquid air, *See* Air. hydrogen, 154
- Livesey tar separator, 344
- Lynn ammonia recovery plant, 340
- MAURICHEAU-BEAUPRÉ process, 231
- Measurement of rate of flow, 29-33
- Melsens-Pictet sulphur dioxide process, 276
- Messerschmitt hydrogen process, 178, 182-4
- Meters, gas, 29
- Methane equilibrium, 189
- production from carbon monoxide, 209, 240-41, 251-2
- Mine rescue apparatus, 78-9
- Mineral waters (artificial), 269-70
- Mond gas, 339-40
- nickel process, 242, 243-8
- producer, 334, 335, 336
- Moore lamp, 129
- producer, 338-9
- NATURAL gas, 354-5
- Neon, 128-30
- Nernst Heat Theorem, 14-16, 135, 216, 240, 253, 285
- Nickel carbonyl, 241, 243-4
- Niton, 132-3
- Nitrogen, 110-22; properties, 110, 111
- Manufacture, 79-92, 111-16; by the fractionation of liquid air, 79, 92, 112; by direct chemical removal of the oxygen from air, 112-14; from producer gas and products of combustion, 114-15; by physical methods (in the gaseous state), 115-16; by direct chemical methods, 116
- Purification, 116-17; cost and purity, 117; applications (nitrogen fixation), 117-22; estimation and testing, 122
- Nitrogen content of coal, 327-8
- fixation, 117-21
- Nitrous oxide, 285-90; properties, 43-5, 285-6; manufacture, 286-8; purification, 288; applications, 288-90
- OECHELHAUSER hydrogen process, 192, 193-4
- Orifice meters, 29, 30
- Ostwald process, 108, 121
- Otto ozone system, 144
- water sterilization system, 147, 148
- Oxalates, synthetic production of. *See* Formates.
- Oxygen, 93-109; properties, 93
- Manufacture, 79-92, 94-100; by the fractionation of liquid air, 79-92, 94; by electrolysis, 94-5, 194-203; by alternate formation and decomposition of higher oxides, etc., 95-8; by auto-combustion methods, 98; by the action of water on peroxides and the like, 98-9; by physical methods (in the gaseous state), 99-100

Oxygen—*continued.*

- Compression, 42, 100-01; cost and purity, 101-2; applications, 102-8; estimation and testing, 108-9
- Oxygen-enriched air, 106-8
- Oxygenite, 98
- Oxylithe, 99
- Ozonair air purification system, 148-9
  - ozone system, 144
  - water sterilization system, 147
- Ozone, 134-51; occurrence, 134; properties, 134-36
  - Production, 136-40; by chemical methods, 137; by thermal treatment of oxygen, 137-8; by electrolysis, 138-9; by photochemical means, 139; by the electric discharge, 139-40
  - Manufacture, general principles of ozonizers, 140-43; commercial ozonizers, 143-5
  - Applications, 145-51; water sterilization, 145-8; air purification, 148-9; chemical applications, 149

PELOUZE and Audouin tar extractor, 344

Permeability of materials, 9-10, 153-4

Phosgene, 252-4

Physical constants, 53-7

methods of testing purity of gases, 25-6

Pictet oxygen and nitrogen plants, 90-91

Pitôt tube, 30-32

Plumbosan process, 96

Poison gases, 291-4

Power production, from semi-water gas, 341-2

producer plant for, 343-4

suction plants for, 344-7

from coal gas, 351-2

Properties of gas, tables of, 53-6

RARE gases of the atmosphere, 92, 123-33; discovery of, 123-4

Reaction velocity, 17

Reference data, 53-6

Resistance to flow of gases, 22-4

Richmond Gas Stove Co.'s furnace, 351

Rincker and Wolter hydrogen process, 192-3

Ruston suction gas plants, 346

SAFETY precautions with compressed gases, 39-45

Sarco carbon dioxide apparatus, 33  
gas calorimeter, 358

Saturation temperature of air blast, 328-34

Schmidt electrolytic process, 198, 199

Schoop electrolytic process, 198, 200

Schrivier electrolytic process, 198, 201

Schuckert electrolytic process, 95, 198, 202

(Silicon) hydrogen process, 224, 225

Semi-water gas. *See* Gaseous fuels.

Separation of gaseous mixtures, 26-7, 79-81

liquid or solid particles from gases, 27-9

Serpek process, 119-20

Siemens and Halske ozone system, 143-4, 147

water sterilization system, 146-7

Silicol hydrogen process, 225-7, 235

Siemens de Frise water sterilization system, 147

Smith Gas Corporation's tar separator, 344

suction gas plant, 345

Solubility of gases, 8

Solvay process, 269

Sorption, 8-9

Space-velocity, 18

Space-time-yield, 18

Specific heats of gases, 11-13

Storage of gas, 52

Strache hydrogen process, 185

Stream-line motion, 20-22

Suction gas, 344-7

Sulphur dioxide, 274-84; properties, 43-5, 274-5

Manufacture, 275-80; production of dilute sulphur dioxide, 277-8; concentration of dilute sulphur dioxide, 278-9

Applications, 280-83; estimation and testing, 283-4; liquid sulphur dioxide, 279-80

Sulphur content of coal, 328

Surface combustion, 355-7

friction, 23

Sürth carbon dioxide process, 266-7

THEISSEN fan, 354

Thermochemistry, 13-14

- Tindal water sterilization system, 147  
Tindal de Frise ozone system, 144  
Turbulent motion, 20-22
- VENTURI meter, 30  
Verley vanillin process, 149  
Viscosity of gases, 20-21  
Vosmaer ozone system, 144  
    water sterilization system, 147
- WATER gas, blue, 156, 316-22, 325  
    carburetted, 322-5  
    equilibrium, 157-8, 238-9, 309  
Water sterilization by ozone, 145-8  
Welding autogenous, 103-4  
Wood pulp manufacture, 280-81
- ZENON, 132

## INDEX OF NAMES OF AUTHORS

- ALDER, 113  
 Amagat, 3, 43, 258  
 American Air Nitrates Corporation,  
   119  
 American Cyanamide Co., 113, 119,  
   125  
 American Oxhydric Co., 200  
 Anderson, 227  
 Andrew, 250  
 Archibald, 139  
 Ardol, Ltd., 172  
 Artigue, 99  
 Ashcroft, 232  
 Athion Gesellschaft, 242  
 Austin, 58, 93  
 Auld, 292  
 Avogadro, 1
- BADISCHE ANILIN & SODA FABRIK,  
   120, 156, 158, 159, 161, 162, 168,  
   170, 176, 177, 191, 205, 208, 211,  
   217, 218, 220, 263, 264  
 Baggs, 175, 209  
 Baillio, 225  
 Ball, 263  
 Baly, 79, 80  
 Bamberger, 228  
 Barlow, 196  
 Barnitz, 182, 222  
 Bartelt, 100  
 Barton, 204  
 Baskerville, 289  
 Basset, 276, 277  
 Baur, 181  
 Bayer & Co., 218  
 Becquefort, 204  
 Bedford, 211  
 Behrens, 262  
 Beill, 143  
 Bendixsohn, 138  
 Bénier, 344  
 Benjamin, 242  
 Bergfeld, 98  
 Bergius, 187  
 Bergmann, 276  
 Berlin Anhaltische Maschinenbau  
   A. G. (B.A.M.A.G.), 161, 184,  
   191, 192
- Berliner, 276  
 Bernthsen, 222  
 Berry, 354  
 Berthelot, 143, 248  
 Bischof, 313  
 Binder, 109  
 Bjerrum, 257  
 Blagburn, 112  
 Blum, 198, 222  
 Bock, 256  
 Böck, 228  
 Bodenstein, 18, 19, 126  
 Bohr, 256  
 Bone, 19, 315, 320, 322, 329, 334,  
   337, 338, 341, 347, 355, 356,  
   358  
 Börnstein, 57  
 Bosch, 191, 220  
 Boudouard, 16, 238, 303  
 Bourchaud, 229  
 Boussingault, 96  
 Boyer, 236  
 Bradley, 64, 65  
 Brähmer, 138, 221  
 Brame, 347, 358  
 Bramkamp, 77  
 Bredig, 249, 272  
 Brianchon, 95  
 Brindley, 231  
 Briner, 140, 238  
 Brin's Oxygen Co., 96, 97  
 Briscoe, 133  
 British Oxygen Co., 69, 70, 84, 95,  
   97, 198  
 Brodie, 136  
 Brook, 349  
 Brownlee, 115, 192  
 Brunel, 274  
 Buchanan, 160  
 Bucher, 113, 120, 125  
 Buffa, 200  
 Bulle, 57  
 Bunte, 192, 309, 316, 318,  
   336  
 Burdett, 197  
 Burrell, 40, 202, 355  
 Bush, 29  
 Byk, 99

- CAILLETET, 60  
 Callendar, 298  
 Calvert, 20  
 Campari, 286  
 Campbell, 326  
 Carbonium Gesellschaft, 192  
 Cardoso, 57  
 Caro, 115, 118  
 Carpenter, C., 211  
 Carpenter, H. C. H., 181  
 Carpenter, C. W., 40  
 Carrol, 261  
 Carter, 249, 272  
 Carulla, 204  
 Castner-Kellner, 203  
 Cavendish, 124  
 Cedford Gas Producing Co., 251  
 Centralstelle für wissenschaftlich-  
 technische Untersuchungen, 218  
 Chaillaux, 98, 206  
 Chance, 354  
 Chapman, 135  
 Charles, 2  
 Chaudron, 175  
 Chemische Fabrik Griesheim-Elek-  
 tron, 126, 158, 164, 203, 231  
 Chemische Fabrik von Heyden,  
 A. G., 204  
 Chemische Fabrik vorm. Moritz,  
 Milch & Co., 187  
 Churchill, 197  
 Chwolson, 56  
 Clamond, 204  
 Claude, 68, 81, 92, 126, 128, 129,  
 170, 210  
 Claus, 210  
 Clayton, 215  
 Clement, 138  
 Clerk, 358  
 Coehn, 95  
 Collie, 129  
 Colton, 288  
 Compagnie du Gaz de Lyons, 159  
 Consortium für Elektrochemische  
 Industrie, G.m.b.H., 224  
 Cottrell, 28, 130, 132  
 Cowap, 244  
 Coward, 40, 241, 299, 300  
 Cowper-Cowles, 197  
 Crofts, 57, 110, 152, 257  
 Crookes, 208  
 Crossley, 122, 222  
 Cyanidgesellschaft, 112
- DALTON, 2  
 Dammer, 199  
 D'Arsonval, 196, 204  
 Davy, 286, 355  
 Deguide, 204
- De Jahn, 218  
 Dellwik, 320  
 Dellwik - Fleischer Wassergas  
 G.m.b.H., 176  
 Dempster, 177, 178  
 Dendy, 271  
 Denis, 250  
 De Villepique, 100  
 Dewar, 10, 79, 102, 127, 128, 129,  
 132, 153, 154  
 Dieffenbach, 176, 185, 186, 190, 207  
 Dixon, 299, 300, 301  
 Don, 151  
 Dorn, 131  
 Dowson, 344, 358  
 Dreaper, 115  
 Dubox, 250  
 Durand, 140  
 Dykema, 355
- EASTWICK, 204  
 Eberlein, 277  
 Edgar, 153  
 Egloff, 355  
 Elektrizitäts, A. G., vorm. Schuckert  
 & Co., 197  
 Elektrizitätswerk Lonza A. G., 113  
 Elektrochemische Werke, Bitterfeld,  
 249, 251  
 Elkan Erben, G.m.b.H., 231  
 Ellis, 115, 192, 193, 215, 221, 250  
 Elmore, 287  
 Elworthy, 114, 204  
 Enderli, 272  
 Engelhardt, 109, 222  
 Engels, 165  
 Erdmann, 215, 251  
 Erlwein, 141, 142, 151  
 Escher, 57  
 Evans, 211  
 Eycken, 197
- FALK, 300  
 Farbarwerke vorm. Meister, Lucius &  
 Brüning, 106, 113  
 Fay, 239  
 Feldkamp, 205  
 Ferguson, G. E., 239  
 Ferguson, J. B., 274  
 Fielding, 229  
 Filippo, 126, 128  
 Fink, 18  
 Finke, 112  
 Firth, 153  
 Fischer, F., 125, 138, 139, 202  
 Fischer, H., 258  
 Flagg, 286  
 Fletcher, 104  
 Foersterling, 99, 231



- Fonda, 126, 248  
 Fonrobert, 150  
 Forshaw, 241  
 Forster, 349  
 Fournier, 100  
 Fourniols, 236  
 Frank, 115, 118, 209  
 Franke, 112  
 Frankland, 222  
  
 GARNER, 92  
 Garners and Metals Research Co.,  
 276  
 Garuti, 196, 197  
 Gas Developments, Ltd., 181  
 Gas Light and Coke Co., 324  
 Gauger, 40, 202  
 Gautier, 59, 152, 205  
 Gay Lussac, 2  
 Gayley, 51  
 Geeraerd, 197  
 General Chemical Co., 220  
 General Electric Co., 144  
 Gérard, 145  
 Gerhartz, 176  
 Gesellschaft für Linde's Eismas-  
 chinen, A.G. *See* Linde.  
 Giffard, 176.  
 Glässner, 181  
 Goldschmidt, 249, 250  
 Goldstein, 140  
 Goosmann, 262, 265, 273  
 Graham, J., 153  
 Graham, J. I., 254  
 Gray, 141  
 Greenwood, 34, 108, 217, 218, 222,  
 350  
 Griesheim - Elektron Co. *See*  
 Chemische Fabrik Griesheim-  
 Elektron.  
 Grillo, 278  
 Grouven, 260  
 Guillet, 211  
 Gutbier, 153  
 Gutzeit, 235  
 Gwosdz, 309, 310  
  
 HABER, 25, 26, 56, 215, 216, 217,  
 218, 222, 249, 309  
 Hacker, 344  
 Haddon, 112  
 Hadfield, 341, 351  
 Hahn, 309  
 Hähnel, 125  
 Hale, 64, 65  
 Haller, 284  
 Hamburger, 128  
 Hampson, 61  
 Hänisch, 275  
  
 Hanmann, 99  
 Harger, 98, 115  
 Harpf, 284  
 Harpster, 25  
 Harries, 309, 316, 317, 318  
 Harries, C., 136, 150  
 Hart, 276  
 Hartley, 349  
 Hausbrand, 50, 57  
 Hawkins, 229  
 Helmholtz, 298  
 Hélouis, 100, 205  
 Hembert, 159  
 Henderson, 222  
 Henning, 110, 257  
 Henry, 8, 159, 239  
 Heræus, 198  
 Herman, 355  
 Heuse, 57  
 Hildebrand, 97  
 Hillebrand, 124  
 Hiller, 210  
 Hird, 283  
 Hirtz, 244  
 Hocking, 348  
 Hofmann, 155, 235, 255  
 Holborn, 12, 58, 93, 110, 257  
 Hollandsche Residugas - Maats-  
 chaapij, 192  
 Holt, 153  
 Hooton, 206  
 Horak, 253  
 Howard, 262  
 Hubert, 353  
 Humphrey, 100  
 Humphreys & Glasgow, 178, 322  
 Hunter, 285  
 Huntingdon, A. K., 208  
 Huntingdon, T., 277  
 Hutchinson, 354  
 Hutin, 205, 277  
 Hutton, 113, 242, 350  
  
 INTERNATIONAL CHEMICAL Co., 224  
 International Oxygen Co., 105, 199  
 Internationale Wasserstoff A.G.,  
 184  
 Ipatiew, 214  
  
 JACOB, 175  
 Jakob, 12, 58  
 Jaubert, 98, 99, 178, 224, 225, 227,  
 228  
 Jenks, 328  
 Johnson, J. E., 107  
 Johnson, J., 167, 260  
 Jones, 135  
 Josse, 50  
 Jost, 216

- Joule, 10, 11  
 Jouve, 205  
 Jungfleisch, 274  
 Junker, 13  
 Jurisch, 9  
  
 KALTENBACH, 277  
 Kammerlingh Onnes, 61, 131  
 Kastner, 96  
 Katz, 250  
 Kausch, 92, 273  
 Kaye, 57  
 Kayser, 130  
 Keable, 322  
 Kendall, 206  
 Kershaw, 353  
 Kistiakowsky, 127  
 Knecht, 113  
 Knowles, 197  
 Koepp & Co., 249, 250  
 Kolbe, 272  
 Krupp, 186, 271  
 Kubierschky, 100  
  
 LABY, 57  
 Ladenburg, 135  
 Lahousse, 206  
 Lance, 114  
 Landin, 210  
 Landis, 122  
 Landolt, 57  
 Lane, 176, 209, 263  
 Lange, 275  
 Langen, 15  
 Langer, 159, 243  
 Langmuir, 129  
 Larter, 358  
 Latchinoff, 196  
 Le Chatelier, 301  
 Lehmann, 221  
 Leithäuser, 140, 142  
 Leiser, 26  
 Lepsius, 167, 193, 194, 198, 203,  
 221  
 Le Rossignol, 216, 222  
 Leroy, 197  
 Leslie, 264  
 Lessing, 190, 241  
 Levi, 166  
 Levin, 197  
 Lévy, 100  
 Levy, 254  
 Lewes, 176, 319, 320, 323  
 Lidoff, 287  
 Linde, 61, 79, 81, 92, 126, 168, 169,  
 170, 208  
 Linder, 142, 143  
 Lloyd, 283  
 Loiseau, 241  
  
 Lorenz, 199  
 Löwe, 25  
 Lowe, 316  
 Lowry, 111  
 Lucke, 346  
 Luggin, 309, 316  
 Luhmann, 265  
 Lunden, 178  
 Lunge, 34, 56, 222, 273, 275, 284  
 Lussana, 12  
 Luttinger, 250  
  
 M'ARTHUR, 354  
 McBain, 8  
 McCourt, 115, 355  
 McDavid, 299, 300  
 McElroy, 250  
 Machalske, 253  
 Mackey, 261  
 Machtolf, 190, 192  
 Majert, 232  
 Malaquin, 137  
 Malisoff, 355  
 Mallard, 301  
 Mallet, 95, 100  
 Maquenne, 124  
 Maréchal, 96, 186  
 Marengo, 204, 229  
 Markgraf, 316  
 Marselli, 119  
 Marston, 113, 287  
 Martin, 57, 87  
 Marx, 138  
 Maschinenbau-Anstalt Humboldt,  
 170  
 Maschinenfabrik Oerlikon, 197, 199  
 Maschke, 222  
 Massenez, 139  
 Maignon, 220  
 Matter, 287  
 Mauriceau-Beaupré, 231  
 Maxted, 90, 160, 177, 181, 217,  
 222, 241  
 Mazza, 100, 204  
 Meade, 318, 319, 323, 324, 348,  
 358  
 Menne, 104  
 Mercia, 250  
 Merriman, 237  
 Merz, 165  
 Messerschmitt, 177, 207  
 Mewes, 77, 89, 92  
 Miethe, 221  
 Mills, 337  
 Mitchell, 270  
 Moldenhauer, 176, 185, 186, 190,  
 207  
 Molinari, 57, 278  
 Möller, 28

- Mond, A., 28  
 Mond, L., 153, 159, 243, 244, 245  
 Moore, 276  
 Moritz, 197  
 Morris, 32  
 Moser, 255  
 Motay, Tessié du, 96, 164, 186  
 Moulin, 276  
 Müller, 159  
 Murray, 85, 96, 97, 105, 109  
  
 NAEF, 116  
 Näher, 159  
 Nauss, 190  
 Neave, 100  
 Nernst, 14, 56, 137, 257  
 Neumann, G., 153  
 Neumann, K., 329  
 New York Nitrogen Co., 112, 206  
 Newbiggin, 22  
 Nitridfabrik G.m.b.H., 249  
 Norman, 214  
 Norsk Hydro Elektrisk Kvaelstof-  
 aktieselskab, 125  
 Norton, 122, 222  
 Nussow, 205  
  
 OBACH, 196  
 Oehlom, 222  
 Oerlikon Co. *See* Maschinenfabrik  
 Oerlikon.  
 Ohlmer, 19  
 Olszewski, 61  
 Onnes, 61, 131  
 Orange, 129  
 Ovitz, 250  
 Ozouf, 265  
  
 PAAL, 214, 235  
 Pannell, 22, 23, 24, 30, 32  
 Paquet, 221  
 Parkinson, 79, 80, 96, 168  
 Parsons, 121, 220  
 Partington, 108, 222  
 Paterno, 253  
 Patterson, 129  
 Payman, 40  
 Perkin, 151  
 Perl, 113  
 Pernell, 277  
 Petavel, 113, 242  
 Philip, 99, 231  
 Pictet, 43, 60, 105, 191, 282, 288  
 Pintsch, 210  
 Piva, 166  
 Plenz, 40  
 Pompili, 196, 197  
 Ponnaz, 222  
 Porter, 46  
 Power Gas Corporation, 339  
  
 Praceiq, 229  
 Prager, 175  
 Pratis, 204, 229  
 Price, 112  
 Pring, 134, 139  
 Pryor, 260  
 Pullman, 204, 263  
  
 RABENALT, 210  
 Ramsay, 123, 124, 128, 130, 132,  
 133, 153, 276  
 Ransford, 99  
 Rao, 150  
 Rasch, 42, 290  
 Rayleigh, 59, 123, 124, 152  
 Read, 159  
 Regnault, 43, 258, 285  
 Reinhardt, 354  
 Reissig, 210  
 Renard, 196, 211, 230  
 Rhead, 9, 238, 303  
 Ricarde-Seaver, 208  
 Richardson, D., 109  
 Richardson, L. B., 9  
 Richter, 232  
 Rideal, E. K., 151, 255  
 Rideal, S., 151  
 Ridsdale, 177  
 Rieche, 205  
 Riedel, 115  
 Rincker, 190, 192  
 Ringe, 125  
 Robertson, 40, 355  
 Robson, 358  
 Roscoe, 57  
 Rose-Innes, 11  
 Roth, 57  
 Rowley, 344  
 Runge, 100  
  
 SABATIER, 155, 158, 214, 240, 258  
 Sander, 174, 185, 192, 222, 236  
 Sarason, 231  
 Scheel, 57  
 Schering, 149  
 Schmalotta, 265  
 Schmid, 255  
 Schmidt, O., 196, 199  
 Schmidt, R., 132  
 Schmidt, Rudolf, 272  
 Schneider, 155  
 Schönbein, 136  
 Scholl, 207  
 Schoonenberg & Naamloze Ven-  
 nootschap Philips Metal Gloe-  
 lamp-fabrik, 126  
 Schoop, 197  
 Schorlemmer, 57  
 Schriver, 198, 199, 201

- Schröder, 275  
 Schuck, 214  
 Schuckert. *See* Elektrizitäts A.G.  
     vorm. Schuckert & Co.  
 Schwarz, 232  
 Seeker, 239  
 Selby Smelter Commission, 275  
 Senderens, 158, 214, 240, 258  
 Seyler, 327  
 Shenton, 100  
 Shields, 153  
 Siebert, 25  
 Siemens, 61, 68, 139, 196, 206  
 Sieverts, 122  
 Simmersbach, 353  
 Simpson, 277  
 Sinding-Larsen, 98  
 Skita, 214  
 Smith, C. C., 181  
 Smith, R. F. W., 328  
 Smith, R. H., 258, 259  
 Smith, W., 287  
 Smythe, 275  
 Snelling, 205  
 Soc. Anon. l'Oxydrique Française,  
     197  
 Soc. Anon. l'Oxydrique Inter-  
     nationale, 104  
 Societé Christiania Minekompani,  
     220  
 Société Française l'Oxylithe, 226  
 Société Générale des Nitrures, 120  
 Société l'Air Liquide, 165, 170  
 Soddy, 130  
 Södermann, 288  
 Soret, 136  
 South Metropolitan Gas Co., 211  
 Soyer, 227, 235  
 Spence, 113  
 Spencer, 112  
 Squire, 94  
 Stanton, 22, 23, 24, 32, 47  
 Steere, 344  
 Stern, 190  
 Stevenson, 289  
 Stewart, 44, 268, 273  
 Steynis, 143  
 St. John, 190  
 Stopes, 326  
 Storm, 98  
 Strache, 185, 210  
 Streintz, 153  
 Stromeyer, 250  
 Strutt, 111  
 Stuckert, 272  
 Summers, 122  
 TAMARU, 222  
 Taylor, 255, 358  
 Teichmann, 43, 44, 284  
 Teisen, 350  
 Teissier, 98, 206  
 Tellier, 220  
 Terres, 40, 336  
 Thom, 260  
 Thomas, 32  
 Thompson, 136  
 Thomson, 10  
 Thornton, 349  
 Thorpe, 57, 101, 270, 273, 315, 329,  
     358  
 Thorssell, 178  
 Tooke, 347  
 Torley, 287  
 Trassenster, 107  
 Travers, 56, 92  
 Tripler, 61  
 UHLINGER, 115, 192  
 United Alkali Co., 249  
 Usher, 150  
 Uyeno, 231  
 VALENTIER, 132  
 Valon, 106  
 Van der Waals, 7  
 Vandoni, 276  
 Van Marum, 136  
 Verley, 149  
 Verneuil, 221  
 Vignon, 166, 318  
 Villard, 43, 285, 288  
 Voigt, 332  
 Von Wartenberg, 139, 257, 274  
 Vosmaer, 141, 148, 150  
 WACHEMHEIM, 126  
 Wallace, 263  
 Walter, 350  
 Wanz, 228  
 Warburg, 140, 142  
 Wardlaw, 275  
 Washburn, 122, 125  
 Waygouny, 272  
 Weber, F. A., 248  
 Weber, S., 57  
 Weinland, 109  
 Weise, 205  
 Weiskopf, 255  
 Weith, 165  
 Wells, 288  
 Welton, 112  
 Wendt, 314, 334  
 Wentzki, 211  
 Werder, 273  
 Westman, 260  
 Westinghouse Co., 145

- Wheeler, 9, 19, 238, 303, 326, 329,  
334, 337, 338, 347  
White, A. H., 344  
White, S., 94  
Wild, 221  
Williams, C. E., 211  
Williams, F. M., 281  
Williams, T., 208  
Willstätter, 214  
Windhausen, 264  
Wirth, 344  
Wise, 113  
Witkowski, 6, 58, 65  
Wöhler, 41, 78, 175  
Wolf, M., 202  
Wolf, R. B., 276  
Wolter, 190, 192  
Woltereck, 237  
Wood, 328  
Worsley, 250  
Wright, 26  
Wróblewski, 61, 256  
Wroczyński, 238, 286  
Würth, 315  
ZEALLEY, 34, 108  
Zeleny, 258, 259  
Ziegenberg, 151

THE END



# INDUSTRIAL CHEMISTRY

Being a Series of Volumes Giving a Comprehensive Survey of

## THE CHEMICAL INDUSTRIES

Edited by SAMUEL RIDEAL, D.Sc. (Lond.), F. I. C., Fellow of  
University College, London.

### NOW READY

- Coal Tar Dyes and Intermediates** . . . . . E. DE BARRY BARNETT, B.Sc., A.I.C.  
Pp. xviii + 214. **Price, \$3.50**
- Explosives** . . . . . E. DE BARRY BARNETT, B.Sc., A.I.C.  
Pp. xvi + 241, with 33 figs. **Price, \$5.00**
- Plant Products and Chemical Fertilisers** . . . . . S. H. COLLINS, M.Sc., F.I.C.  
Pp. xvi + 236. **Price, \$3.00**
- The Industrial Gases** . . . . H. C. GREENWOOD, D.Sc. (Manchester).  
Pp. xxii + 371. **Price, \$5.00**
- The Alkali Industry** . . . . J. R. PARTINGTON, D.Sc. (Vict.).  
Pp. xvi + 304, with 63 figs. **Price, \$3.00**
- Industrial Electrometallurgy** E. K. RIDEAL, M.A. (Cantab.), Ph.D.,  
F.I.C.  
Pp. xii + 248, with 26 figs. **Price, \$3.00**
- The Application of the Coal Tar Dyestuffs** . . . . . C. M. WHITTAKER, B.Sc.  
Pp. xii + 214. **Price, \$3.00**

### IN THE PRESS

- Animal Proteids** . . . . . H. G. BENNETT, M.Sc. (Leeds).
- The Carbohydrates** . . . . S. RIDEAL, D.Sc. (Lond.), F.I.C., and  
Associates.

### IN PREPARATION

- Fats, Waxes & Essential Oils** W. H. SIMMONS, B.Sc. (Lond.), F.I.C.
- Silica and the Silicates** . . J. A. AUDLEY, B.Sc. (Lond.), F.I.C.
- The Rare Earths and Metals** E. K. RIDEAL, M.A. (Cantab.), Ph.D.,  
F.I.C.
- The Iron Industry** . . . . A. E. PRATT, B.Sc. (Lond.), Assoc.  
R.S.M.
- The Steel Industry** . . . . A. E. PRATT, B.Sc. (Lond.), Assoc.  
R.S.M.
- Gas-Works Products** . . . . H. H. GRAY, B.Sc.
- Organic Medicinal Chemicals** M. BARROWCLIFF, F.I.C., and F. H. CARR,  
F.I.C.
- The Petroleum Industry** . . D. A. SUTHERLAND, F.I.C.
- Wood and Cellulose** . . . . R. W. SINDALL, F.C.S., and W. BACON,  
B.Sc., F.I.C., F.C.S.
- Rubber, Resins, Paints and Varnishes** . . . . . R. S. MORRELL, M.A., Ph.D.; A. E.  
WAELE, and the Editor.







THIS BOOK IS DUE ON THE LAST DATE  
STAMPED BELOW

**AN INITIAL FINE OF 25 CENTS**

WILL BE ASSESSED FOR FAILURE TO RETURN  
THIS BOOK ON THE DATE DUE. THE PENALTY  
WILL INCREASE TO 50 CENTS ON THE FOURTH  
DAY AND TO \$1.00 ON THE SEVENTH DAY  
OVERDUE.

APR 19 1937

FEB 18 1947

2 May '58 J M

REC'D LD

APR 18 1958

TP242

Q8

458793

UNIVERSITY OF CALIFORNIA LIBRARY

